



US00D329166S

United States Patent [19]

[11] Patent Number: **Des. 329,166**

Doggett

[45] Date of Patent: **** Sep. 8, 1992**

[54] **HOUSING FOR A HAND-HELD MIXER**

[75] Inventor: **Lawrence A. Doggett, Stevensville, Mich.**

[73] Assignee: **Whirlpool Corporation, Benton Harbor, Mich.**

[*] Notice: The portion of the term of this patent subsequent to Sep. 8, 2006 has been disclaimed.

[**] Term: **14 Years**

[21] Appl. No.: **449,733**

[22] Filed: **Dec. 12, 1989**

[52] U.S. Cl. **D7/376; D7/379**

[58] Field of Search **D7/376-380, D7/413; 241/37.5, 92, 169.1, 282.1, 282.2**

[56] **References Cited**

U.S. PATENT DOCUMENTS

D. 158,883	6/1950	Morgan	D7/379
D. 182,424	4/1958	Madl	D7/379
D. 183,385	8/1958	Ernest	D7/379
D. 188,284	6/1960	Jepson et al.	D7/379
D. 189,680	1/1961	Chapman et al.	D7/379
D. 201,629	7/1965	Madl	D7/379
D. 201,896	8/1965	Frost	D7/379
D. 202,506	10/1965	Fessenmeyer	D7/379
D. 203,850	2/1966	Chieda	D7/379
D. 207,859	6/1967	Weiss	D7/379
D. 209,461	12/1967	Clough	D7/379
D. 210,475	3/1968	Di Sesa, Jr.	D7/379

D. 211,485	6/1968	Le Sueur	D7/379
D. 212,817	11/1968	Steinkamp	D7/379
D. 221,398	8/1971	Rawson, Jr.	D7/379
D. 222,756	12/1971	Dykes	D7/379
D. 224,132	7/1972	Yamamoto	D7/379
D. 225,765	1/1973	Hall	D7/379
D. 234,333	2/1975	Mantelet	D7/379
D. 279,856	7/1985	Elkerbout	D7/376 X
D. 291,647	9/1987	Steinkamp	D7/379
D. 292,166	10/1987	McCloskey	D7/379
D. 309,079	7/1990	Petrie et al.	D7/379
D. 309,081	7/1990	Thomas	D7/379
D. 310,005	8/1990	Precht	D7/379
D. 315,080	3/1991	Naft	D7/379
3,333,825	12/1962	Wolter	366/344

Primary Examiner—Donald P. Walsh

Assistant Examiner—Caron D. Veynar

Attorney, Agent, or Firm—Thomas J. Roth; Stephen D. Krefman; Thomas E. Turcotte

[57] **CLAIM**

The ornamental design for a housing for a hand-held mixer, as shown and described.

DESCRIPTION

FIG. 1 is a top front perspective view of the housing for a hand-held mixer showing my new design; FIG. 2 is a front elevational view thereof; FIG. 3 is a right side elevational view thereof, the left side elevational being a mirror image thereof; FIG. 4 is a top plan view thereof; FIG. 5 is a rear elevational view thereof; and, FIG. 6 is a bottom plan view, the beater receptacles deleted for ease of illustration.

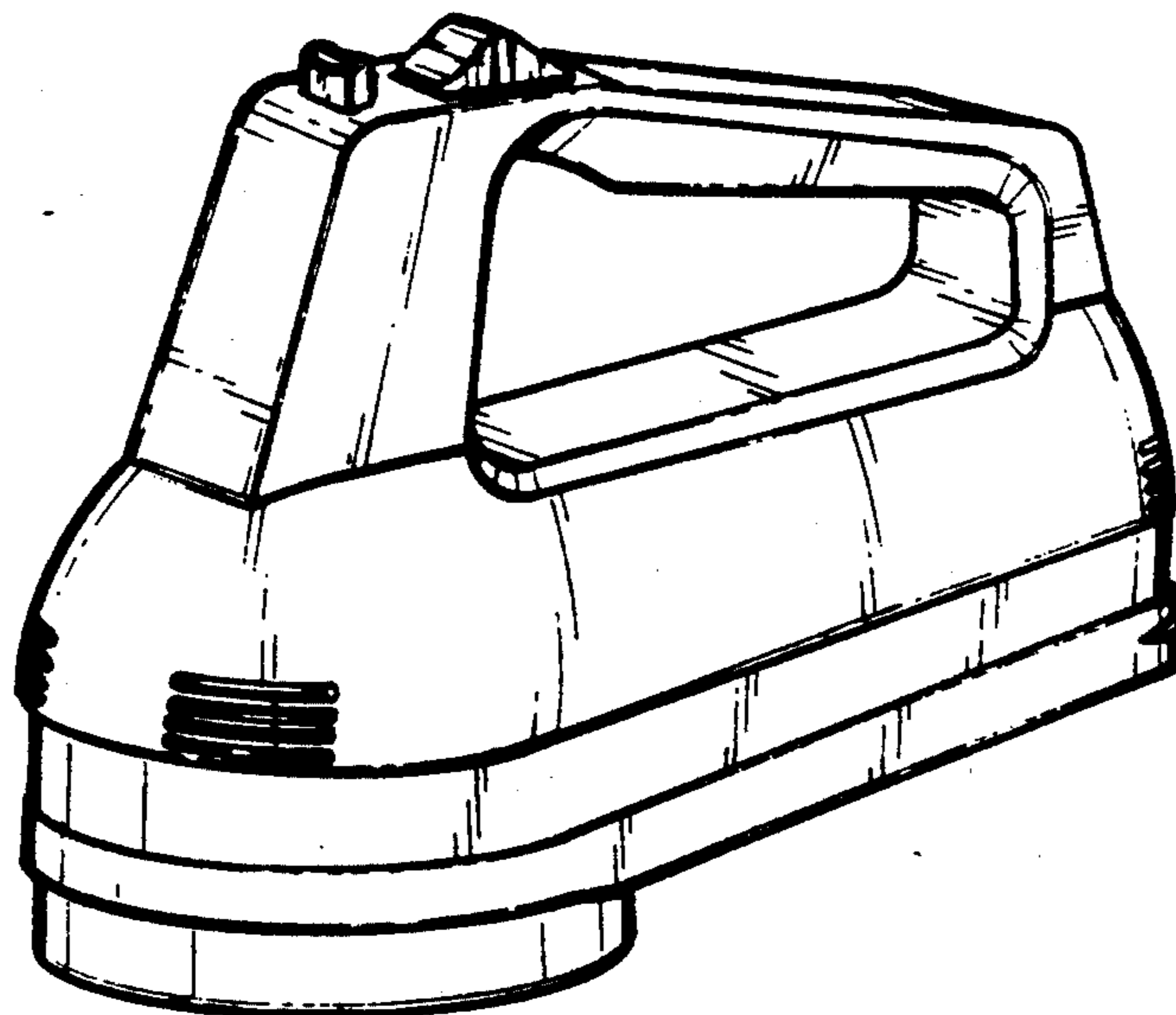

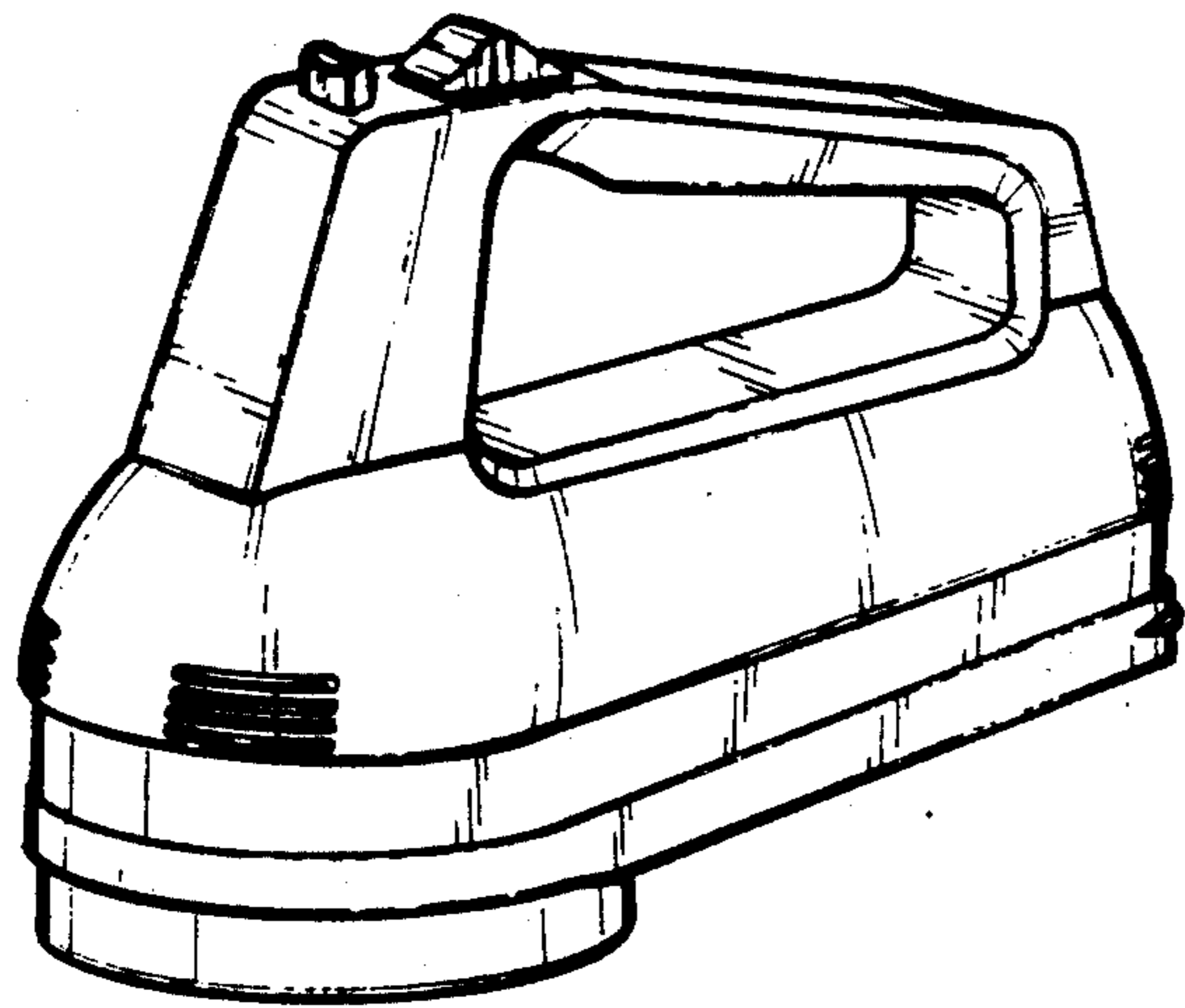

Fig-1

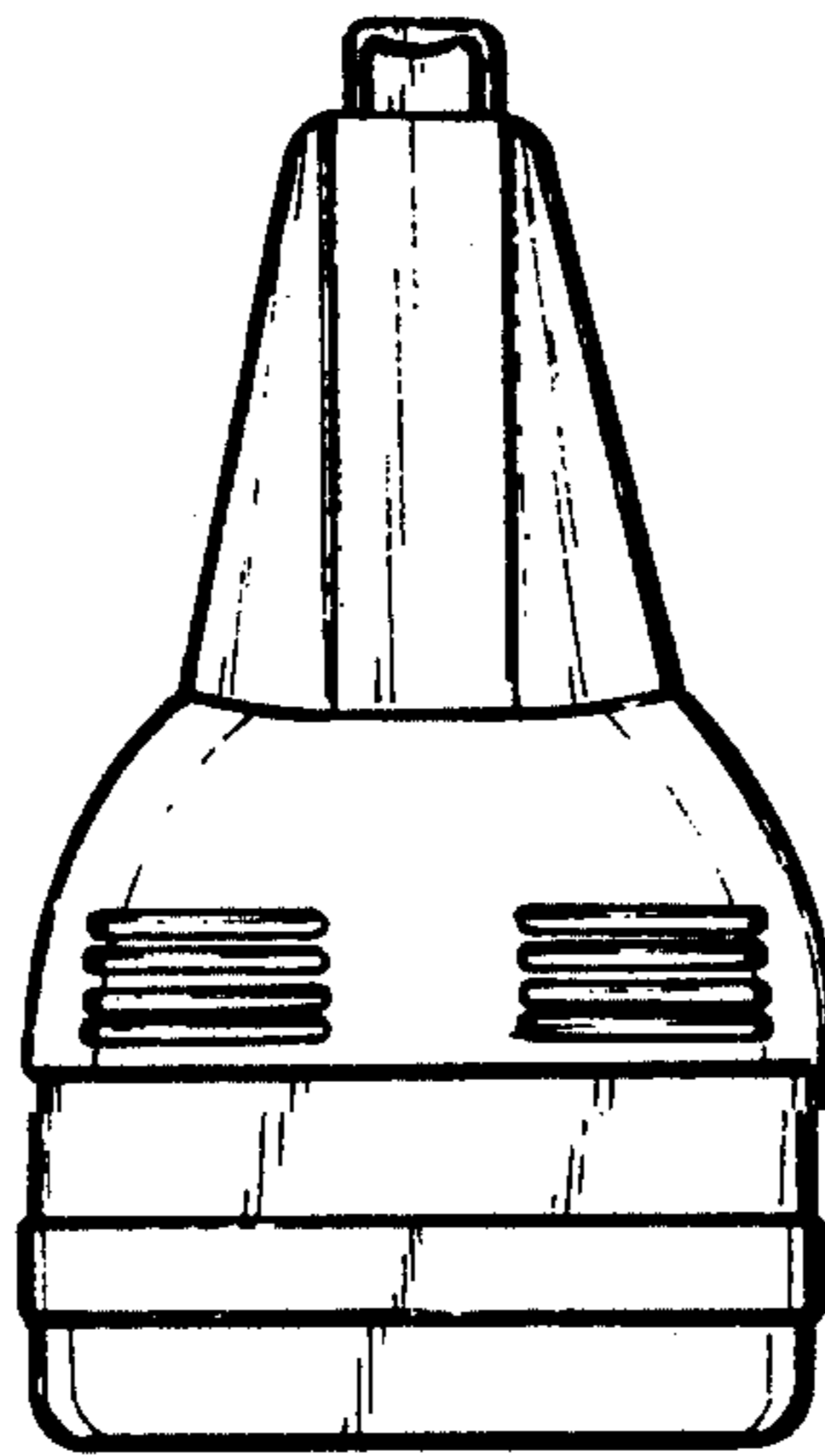

Fig-2

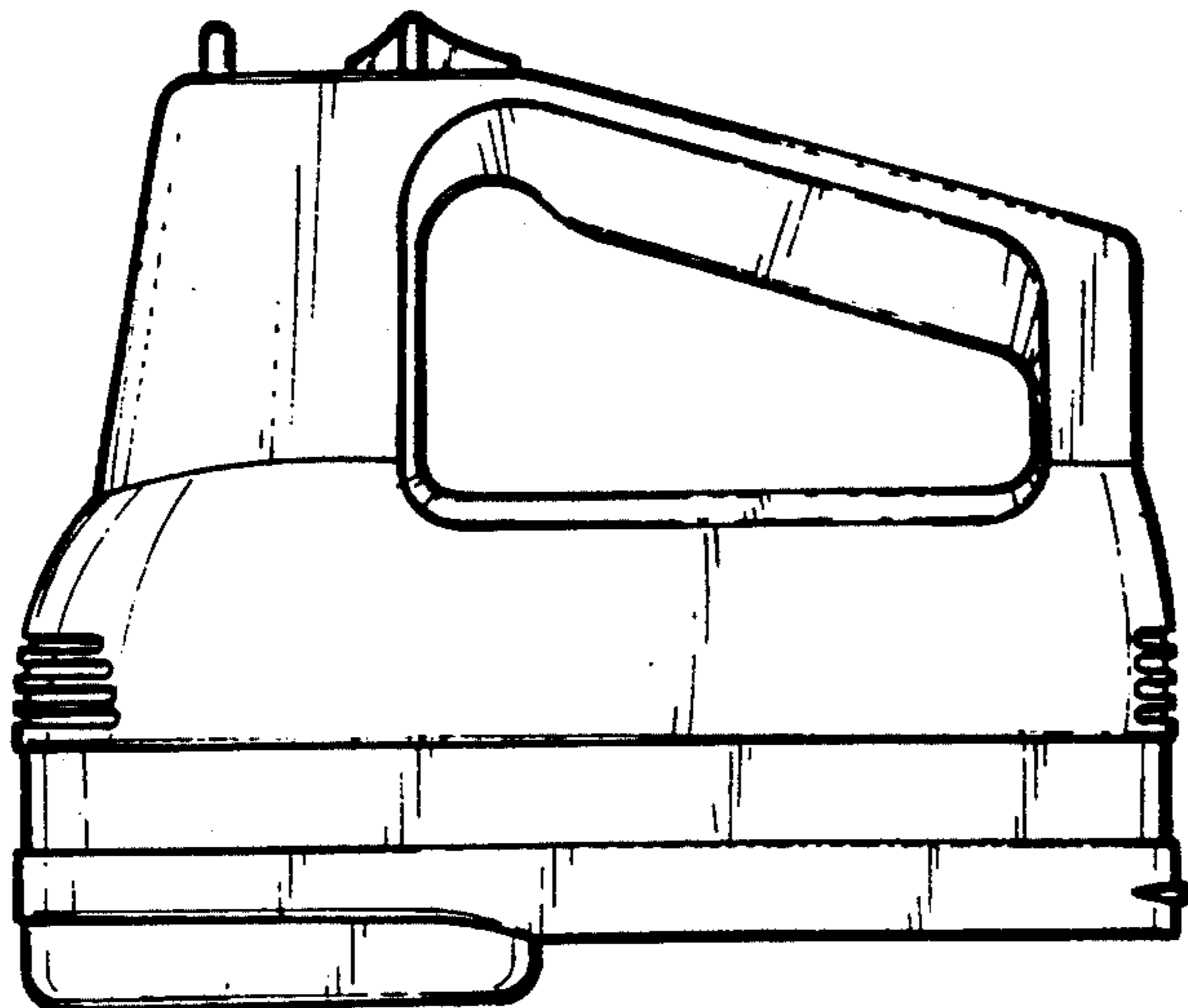

Fig-3

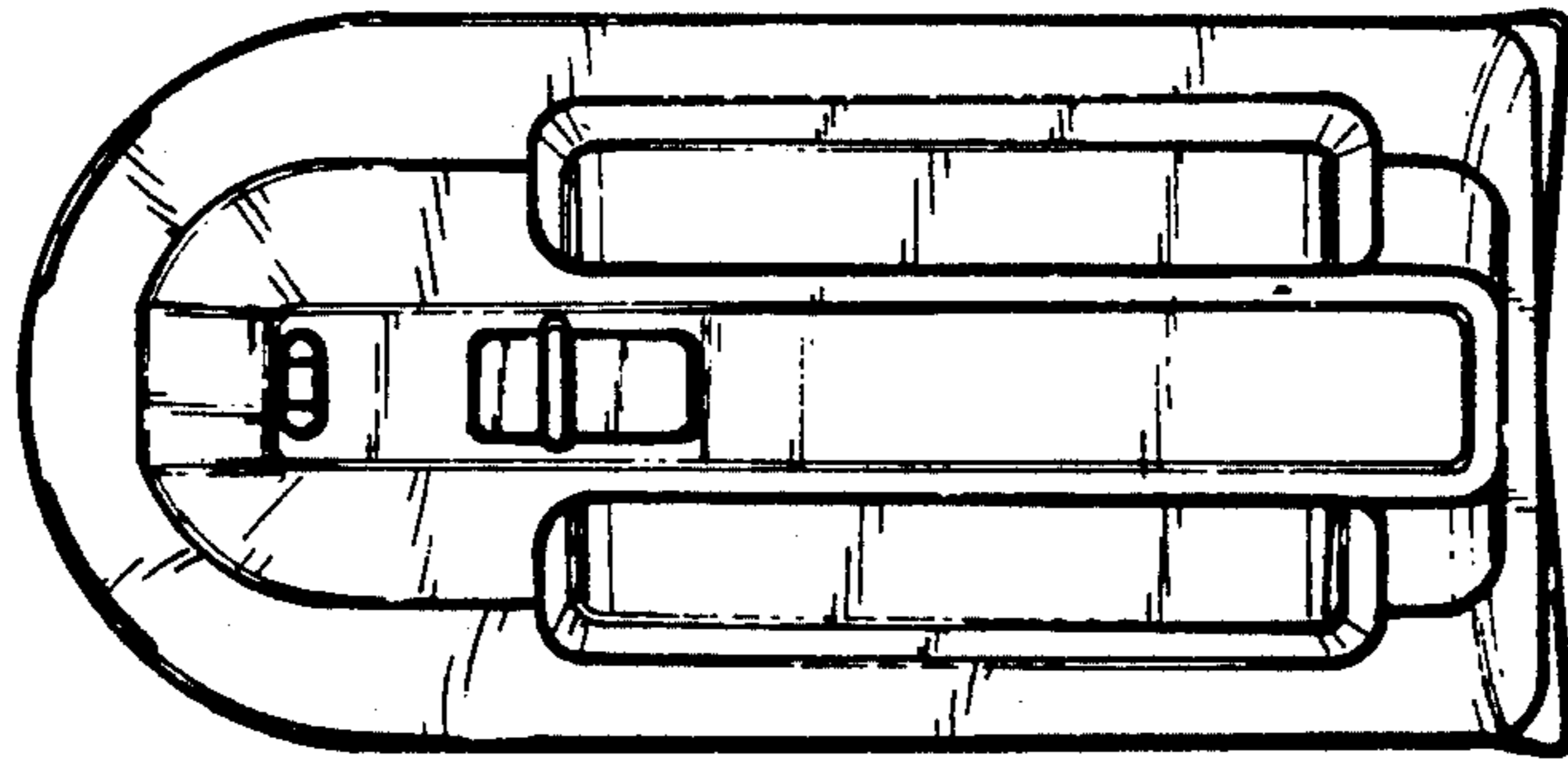

Fig-4

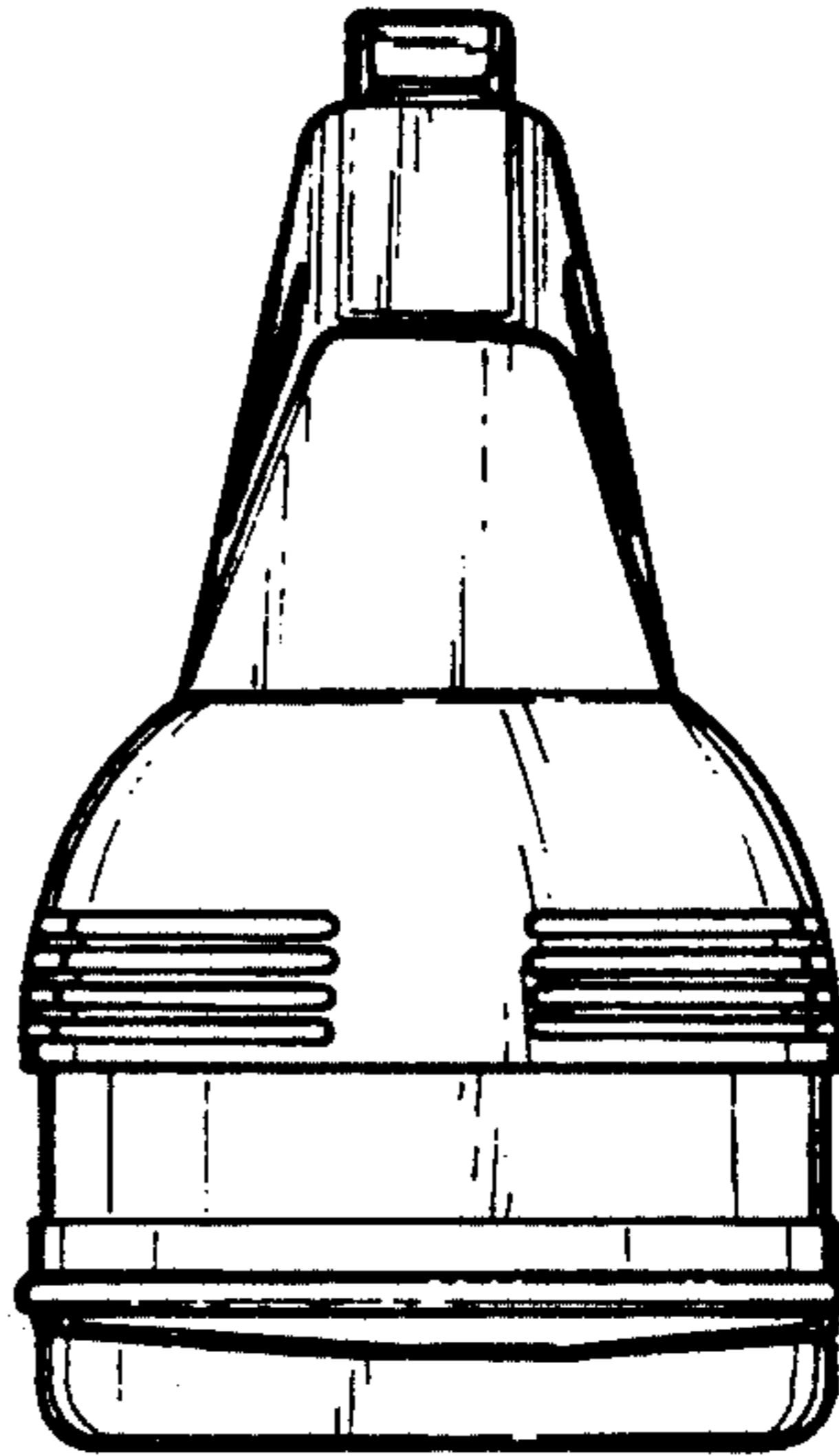

Fig-5

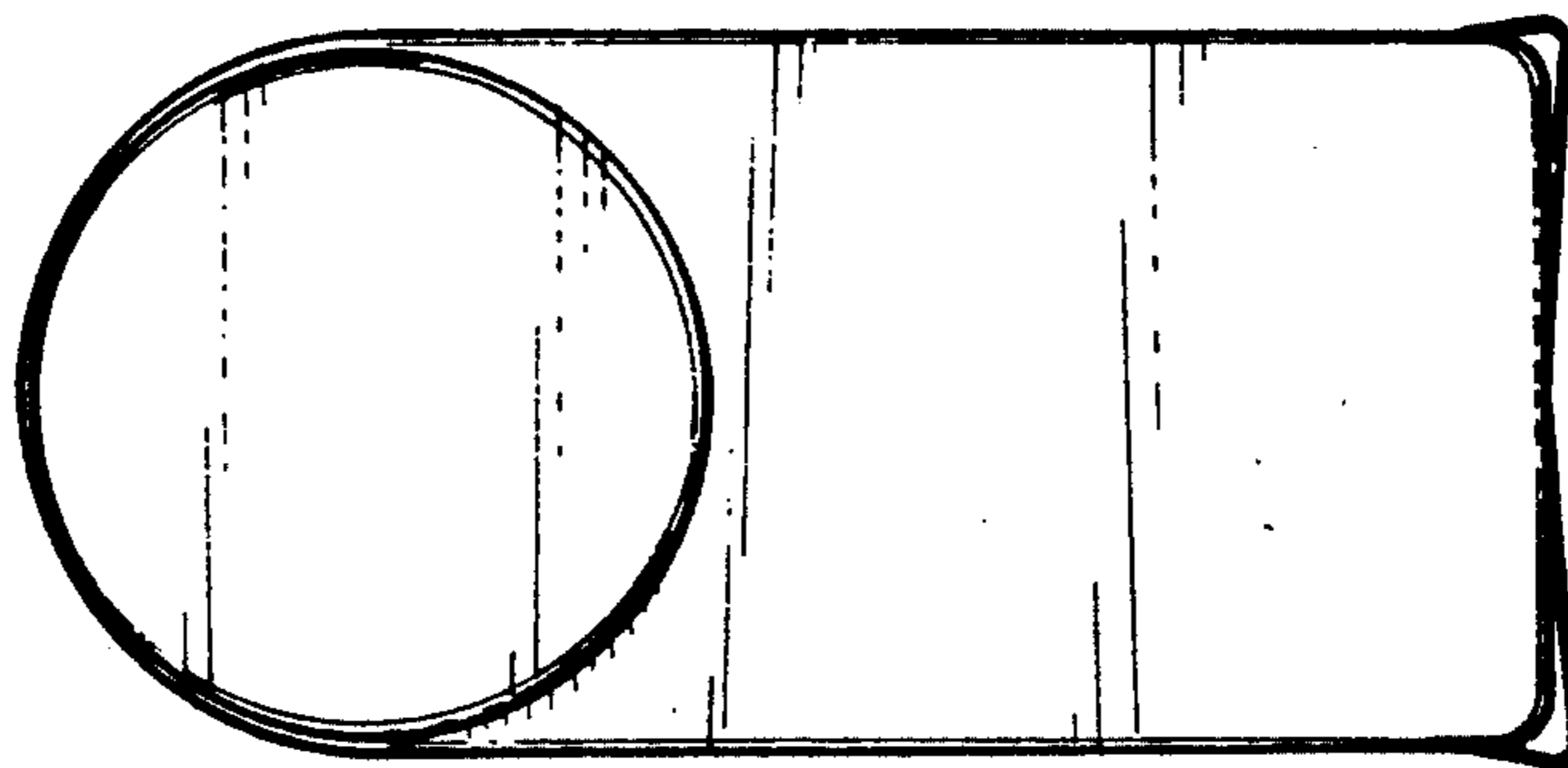

Fig-6