



US00D329147S

**United States Patent** [19]  
**Gandy**

[11] **Patent Number: Des. 329,147**  
[45] **Date of Patent: \*\* Sep. 8, 1992**

[54] **COMBINED TABLE AND BENCH UNIT**

[75] **Inventor: Paul J. Gandy, Tucson, Ariz.**

[73] **Assignee: Marana Unique Products Inc., Marana, Ariz.**

[\*\*] **Term: 14 Years**

[21] **Appl. No.: 349,333**

[22] **Filed: May 8, 1989**

[52] **U.S. Cl. .... D6/337**

[58] **Field of Search ..... D6/335, 336, 337, 368; 297/157, 442**

[56] **References Cited**

**U.S. PATENT DOCUMENTS**

D. 171,751	3/1954	Curtis .....	D6/337
D. 265,787	8/1982	Berquist .....	D6/337 X
D. 313,702	1/1991	Rich et al. ....	D6/335
3,262,734	7/1966	Kuks .....	297/157
4,076,305	2/1978	Sullivan .....	D6/337 X

**OTHER PUBLICATIONS**

Better Homes and Gardens, May 1980, P.59, picnic table shown top right.

*Primary Examiner*—Donald P. Walsh  
*Assistant Examiner*—Gary D. Watson  
*Attorney, Agent, or Firm*—Ogram & Teplitz

[57] **CLAIM**

The ornamental design for a combined table and bench unit, as shown and described.

**DESCRIPTION**

FIG. 1 is a perspective view of a combined table and bench unit showing my new design; FIG. 2 is a top plan view; FIG. 3 is a bottom plan view; FIG. 4 is a left side elevational view, the right side being a mirror image thereof; and, FIG. 5 is a front elevational view, the rear being a mirror image thereof. FIGS. 2 through 5 have been drawn to a smaller scale with respect to FIG. 1.

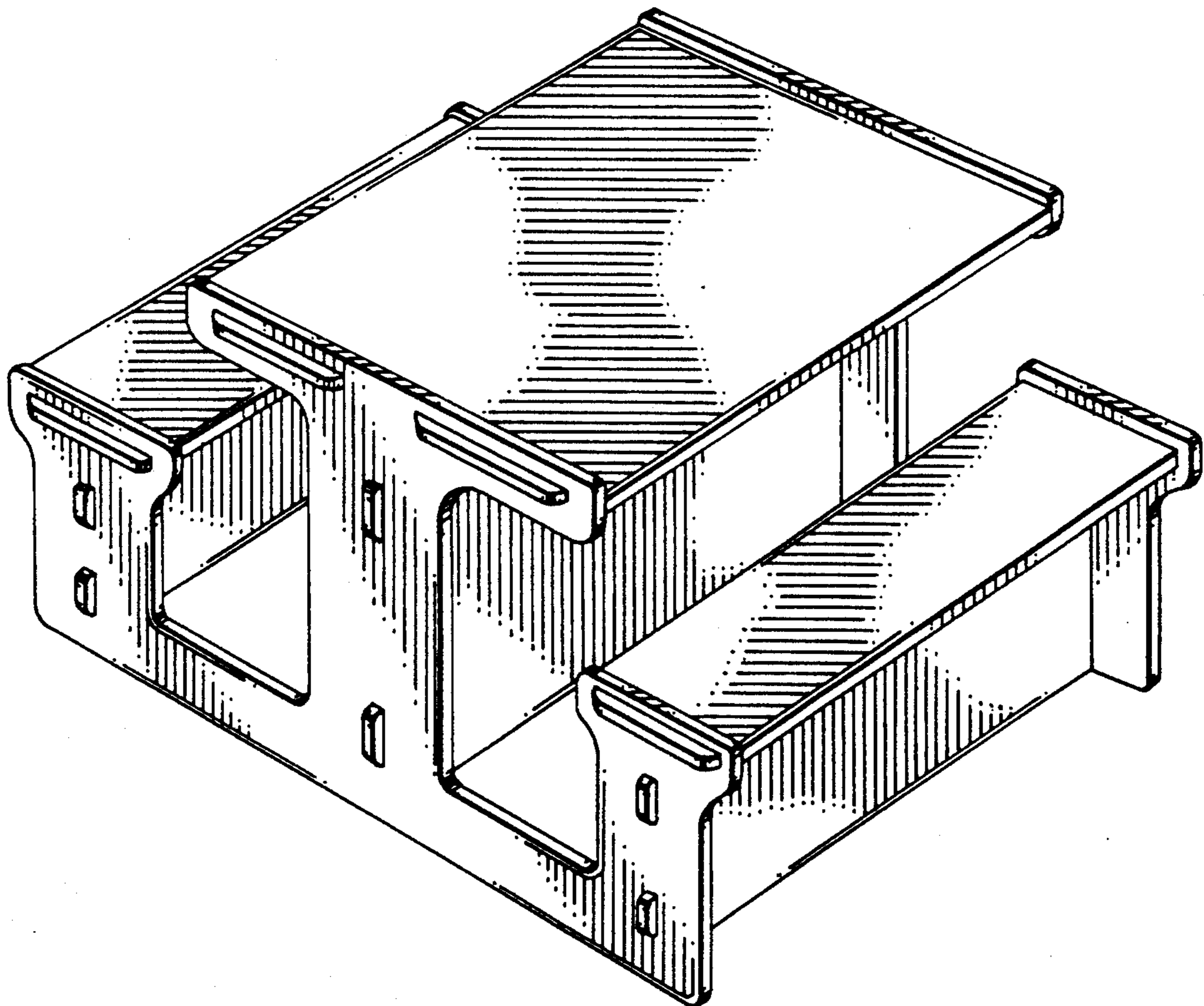

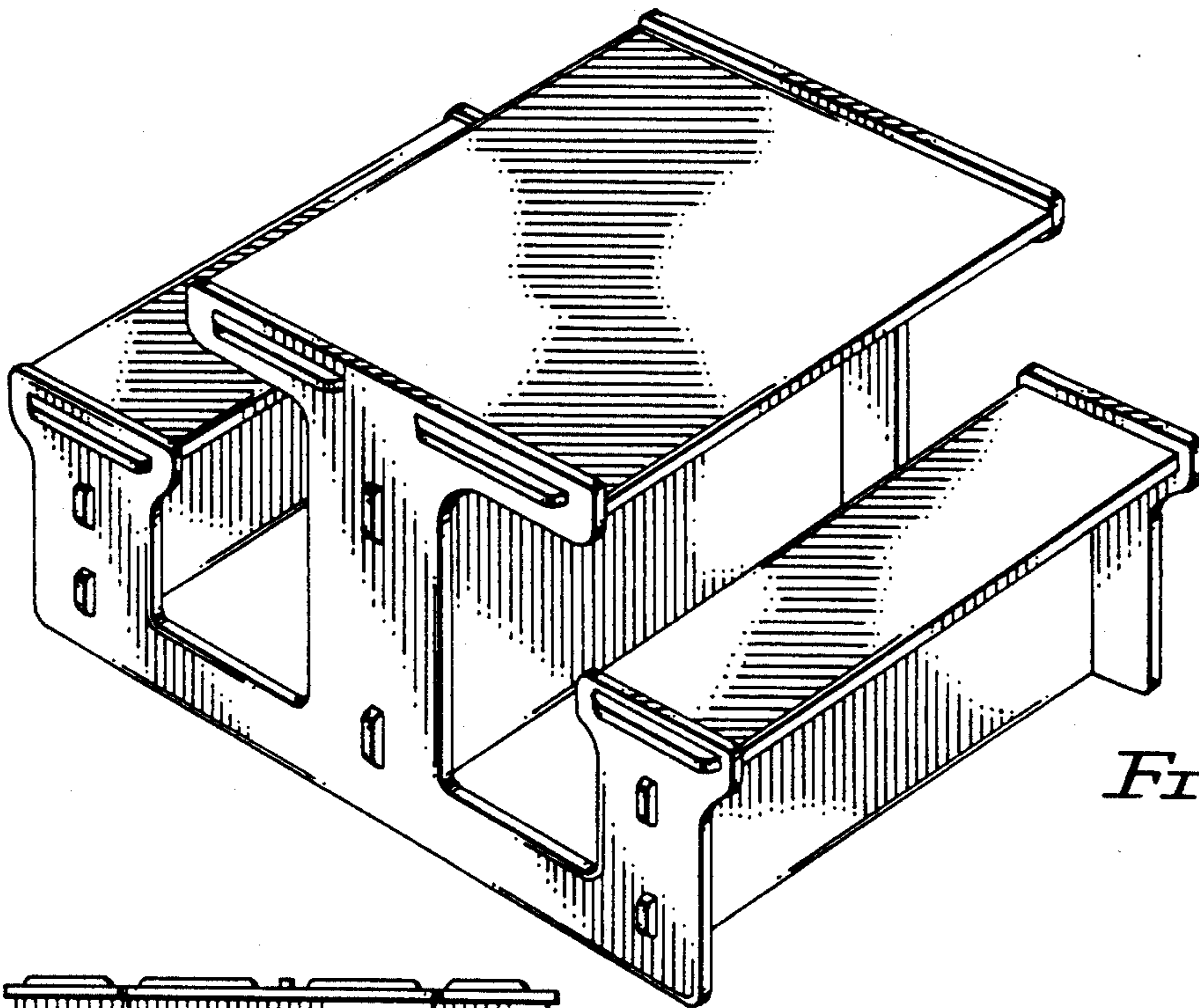

FIG. 1

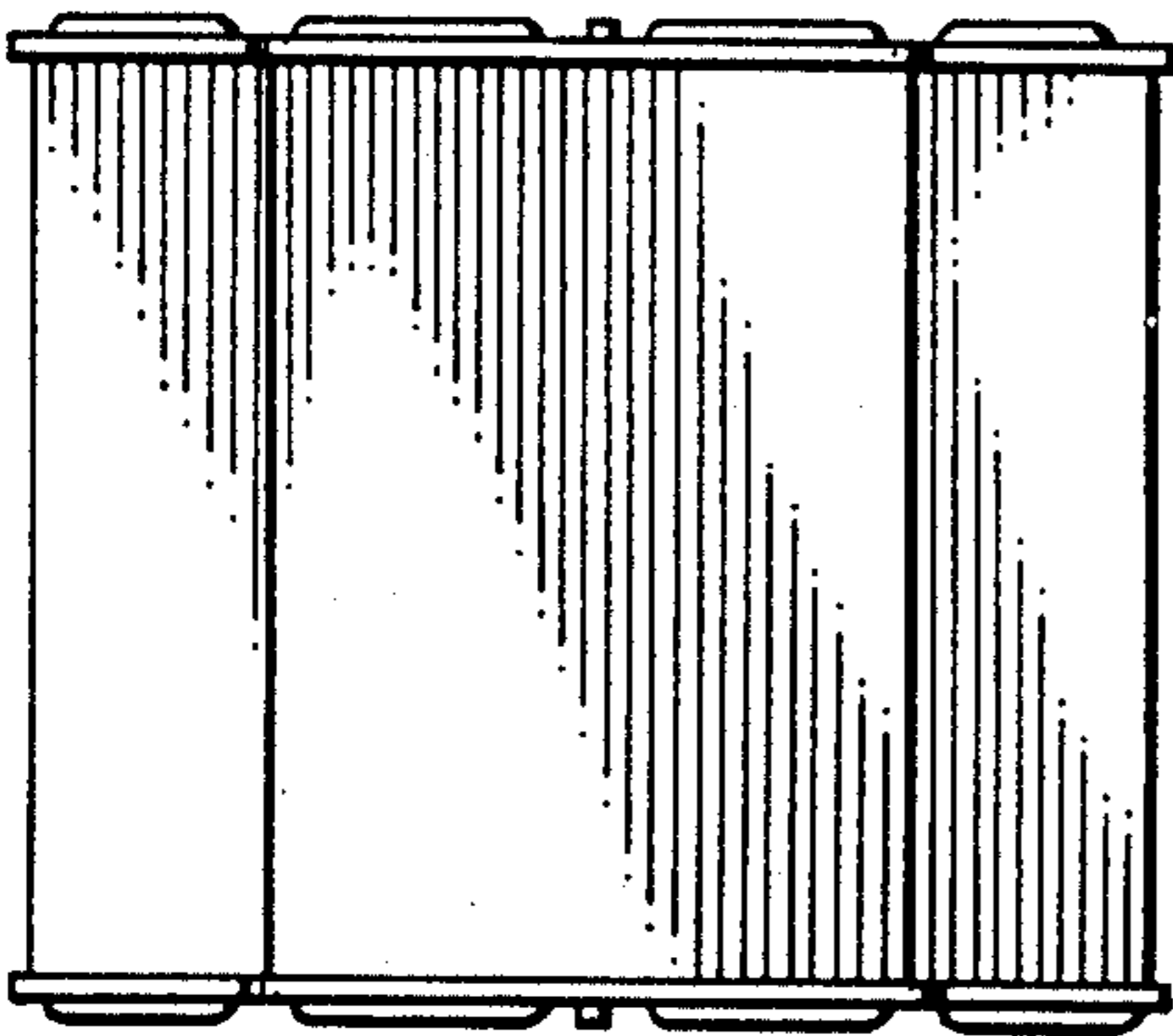

FIG. 2

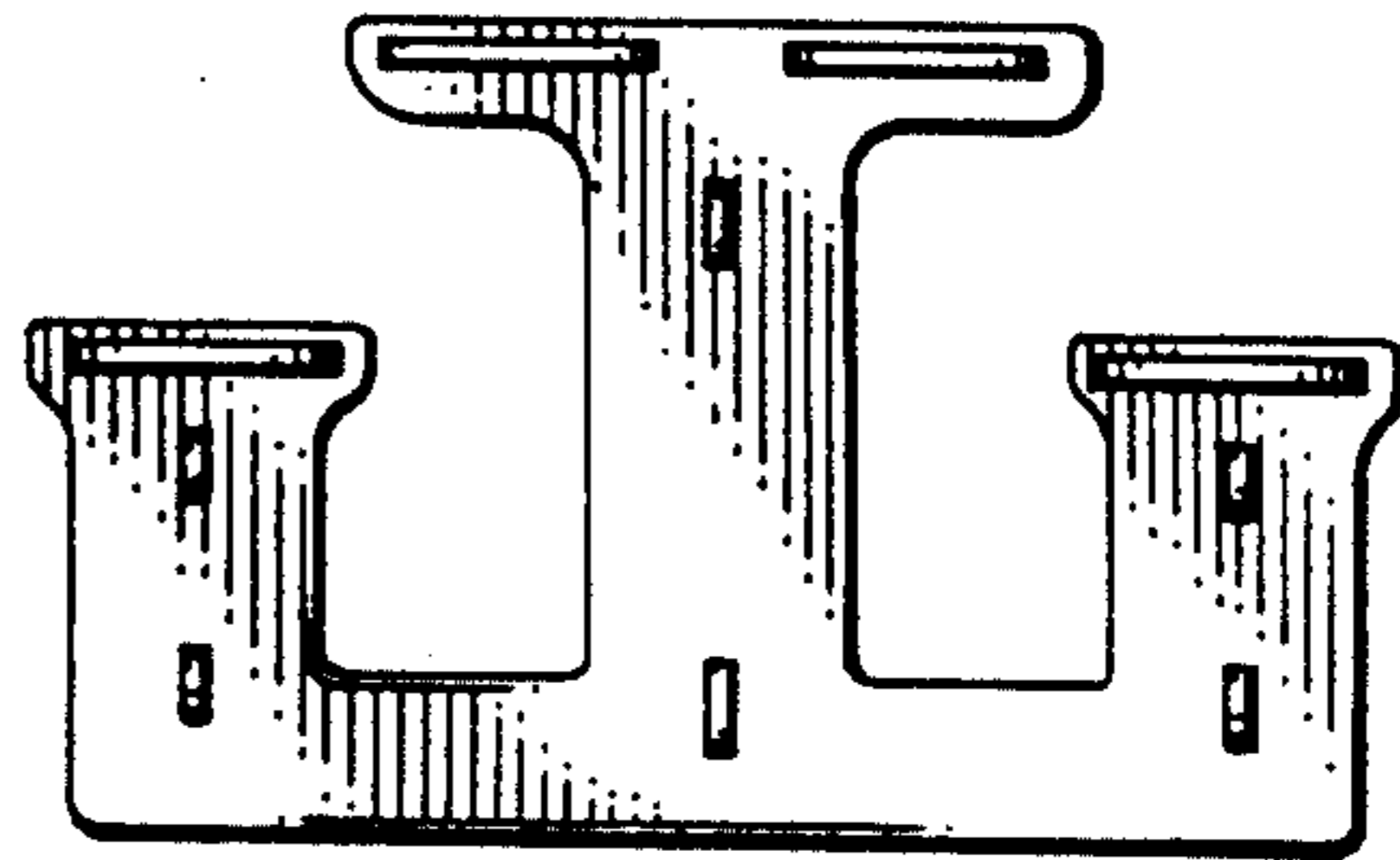

FIG. 4

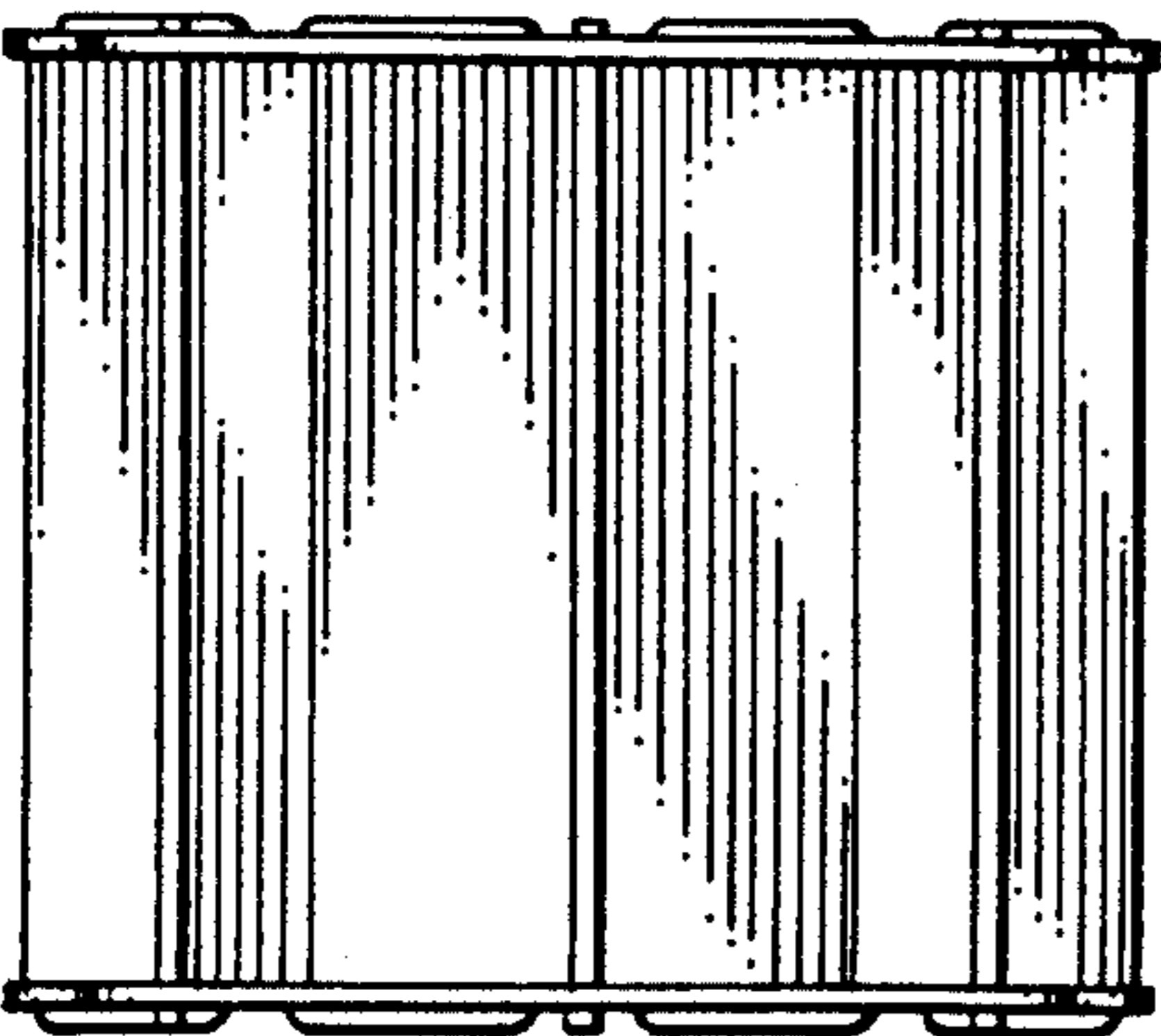

FIG. 3

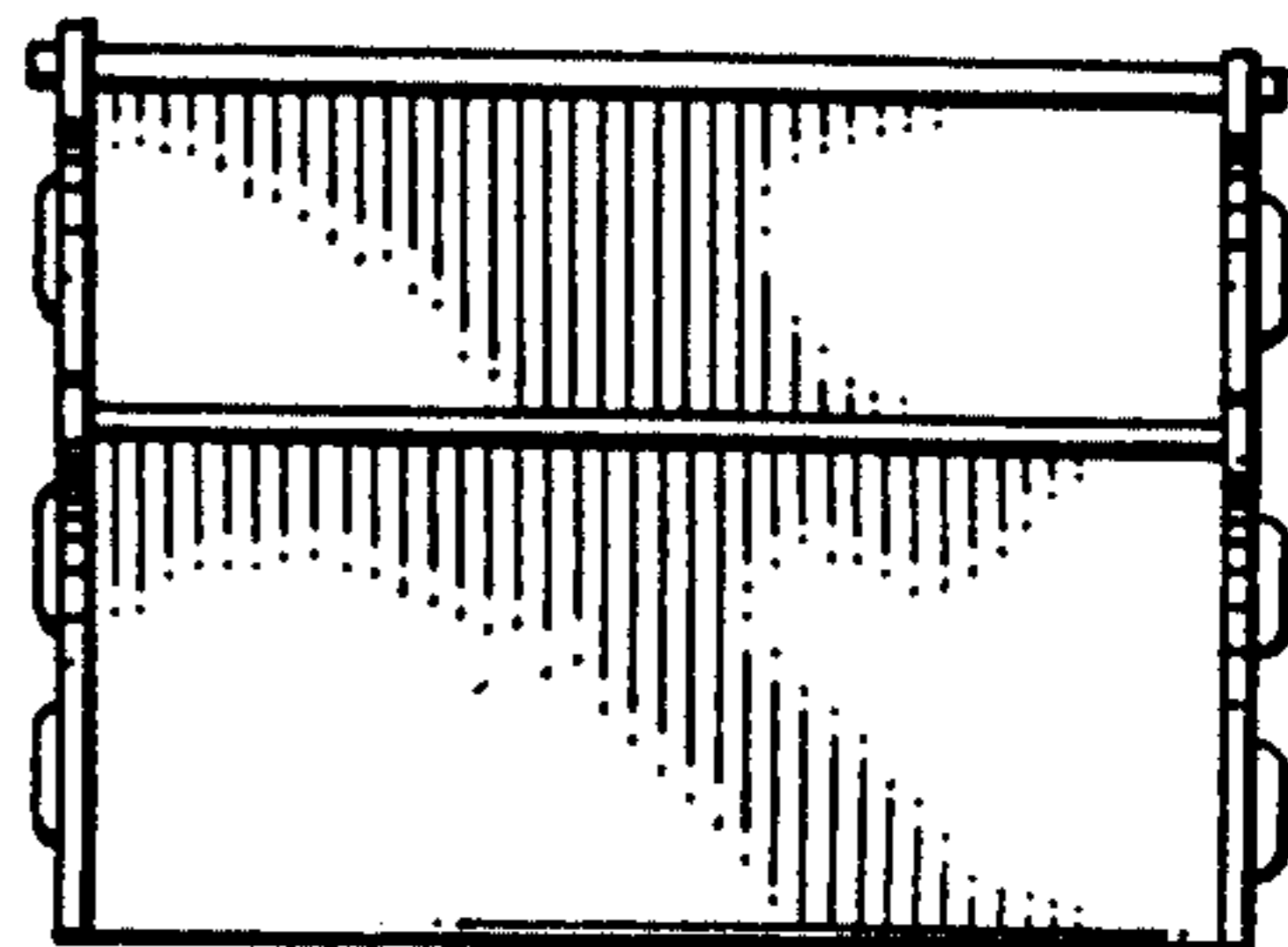

FIG. 5