



US00D329097S

United States Patent [19]

[11] Patent Number: **Des. 329,097**

Sacco et al.

[45] Date of Patent: **** Sep. 1, 1992**

[54] FRONT HEADLIGHT FOR AN AUTOMOBILE

[56] References Cited

[75] Inventors: **Bruno Sacco; Josef Gallitzendörfer**, both of Sindelfingen, Fed. Rep. of Germany

U.S. PATENT DOCUMENTS

D. 271,811	12/1983	Luthe et al.	D26/122
D. 285,352	8/1986	Envall	D26/35
D. 305,940	2/1990	Fukagawa	D26/28
4,912,606	3/1990	Yamamoto	362/61

[73] Assignee: **Mercedes-Benz AG**, Fed. Rep. of Germany

OTHER PUBLICATIONS

Road & Track, Jul. 1989, p. 96, Mercedes-Benz 300sl headlight.

[**] Term: **14 Years**

Primary Examiner—Susan J. Lucas
Attorney, Agent, or Firm—Evenson, Wands, Edwards, Lenahan & McKeown

[21] Appl. No.: **558,854**

[57] CLAIM

[22] Filed: **Jul. 27, 1990**

The ornamental design for a front headlight for an automobile, as shown and described.

[30] Foreign Application Priority Data

DESCRIPTION

Jan. 30, 1990 [DE] Fed. Rep. of Germany M9000651.8

[52] U.S. Cl. **D26/28; D26/120**

[58] Field of Search **D26/28-36, D26/120, 122; 362/61, 80, 81, 82, 83**

FIG. 1 is a front elevational view of a front headlight for an automobile showing our new design;

FIG. 2 is a front, left side perspective view thereof; and, FIG. 3 is a top plan view thereof.

The automobile is shown in broken lines for illustrative purposes only.

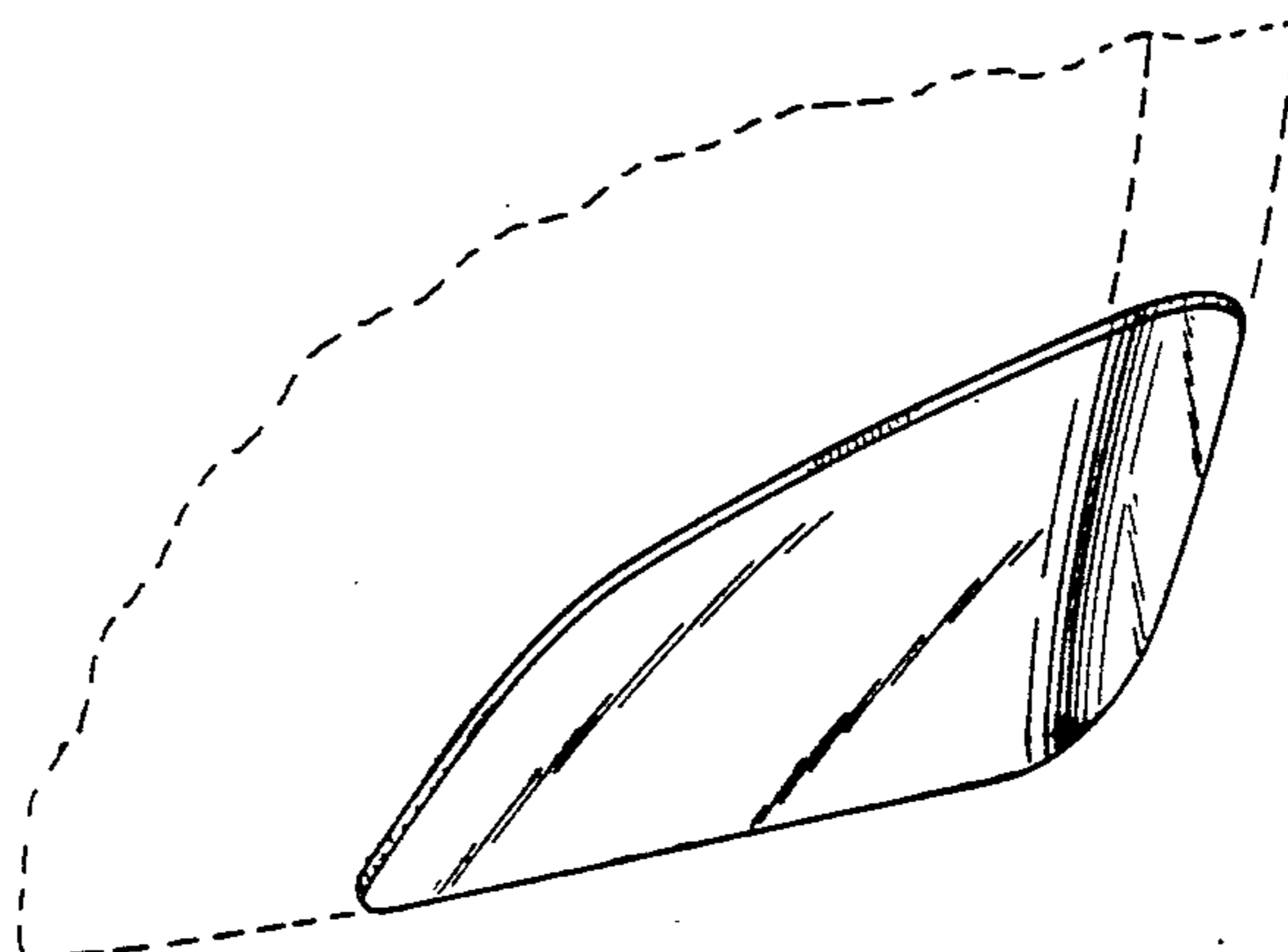
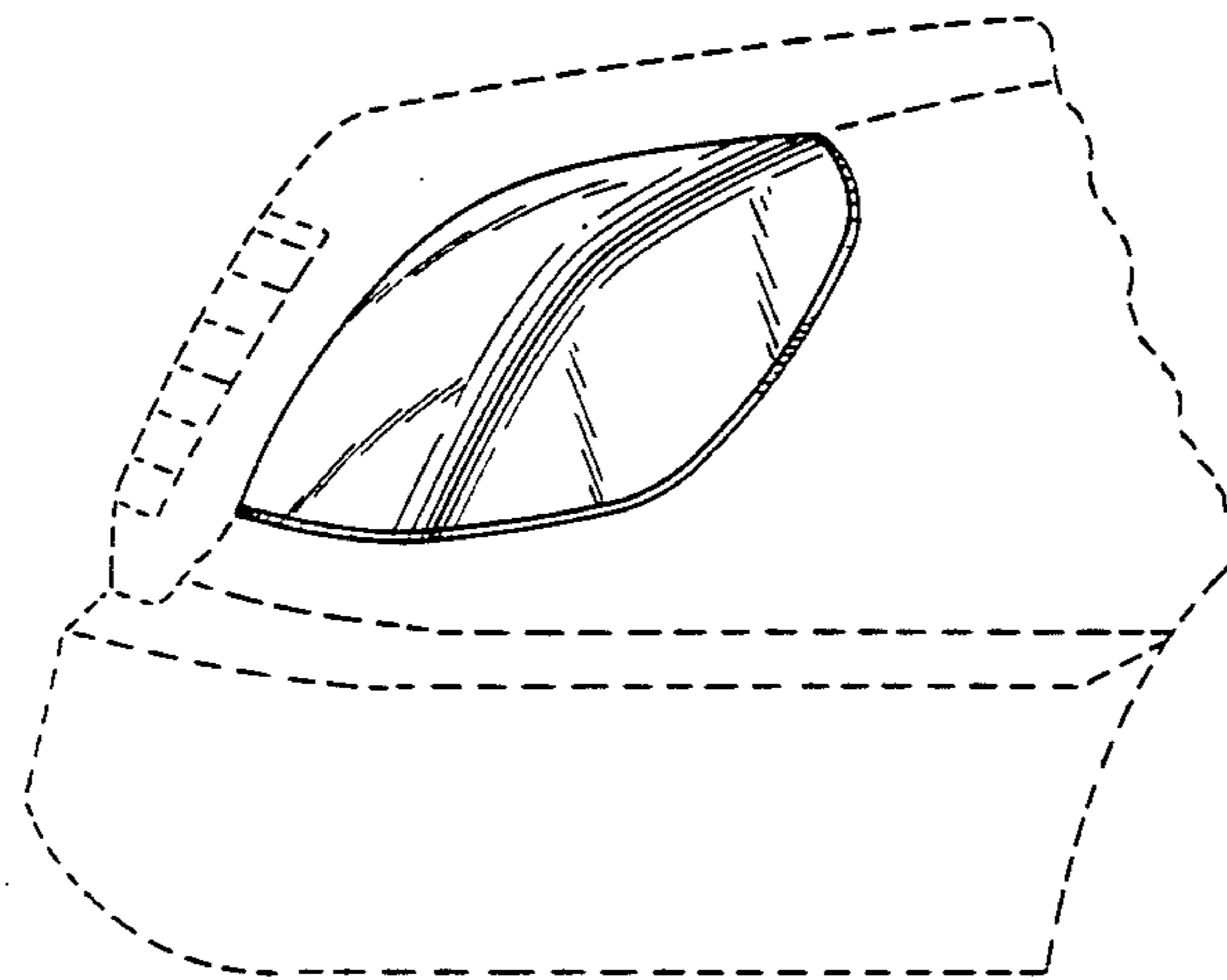

FIG. 1

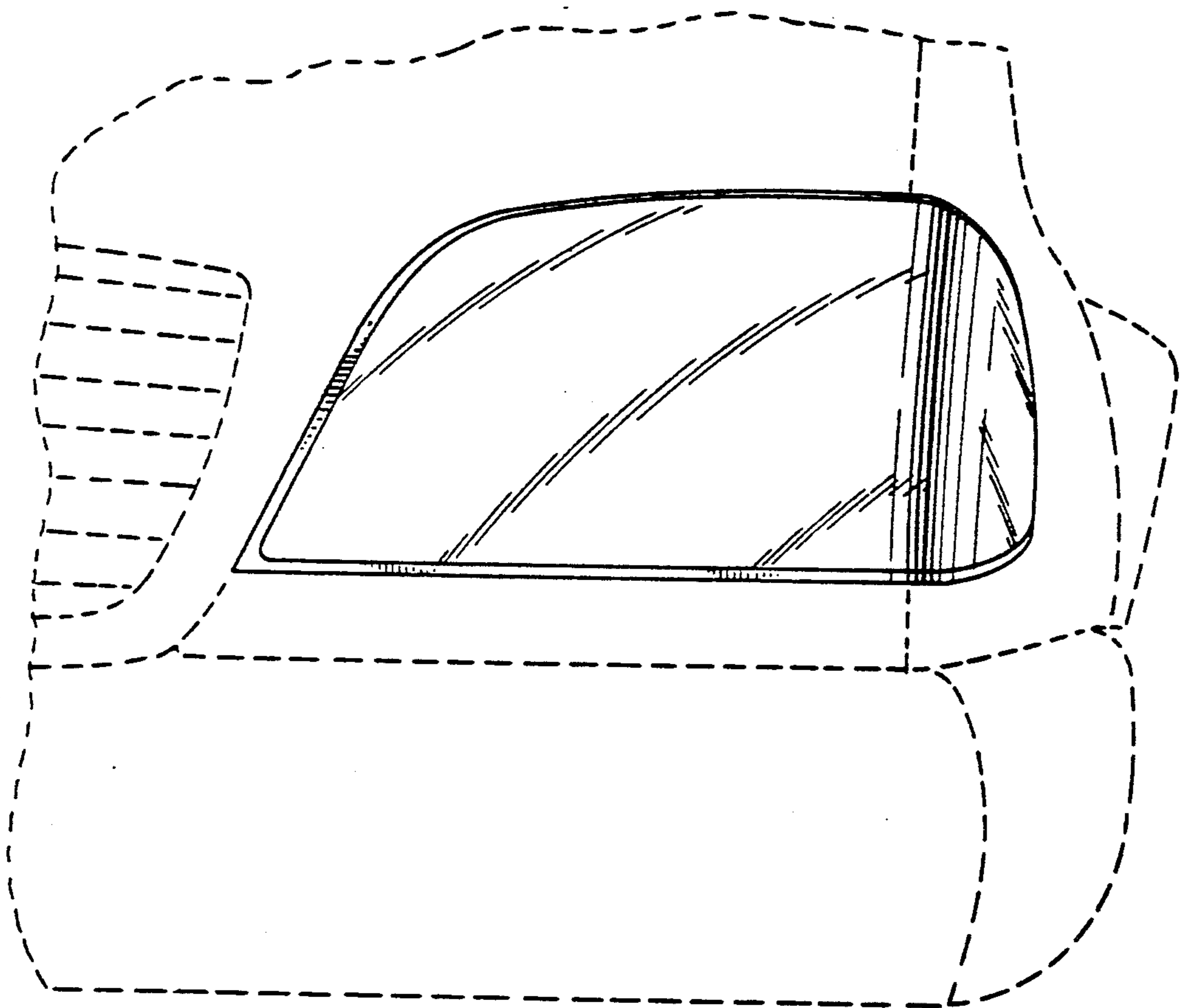

FIG. 2

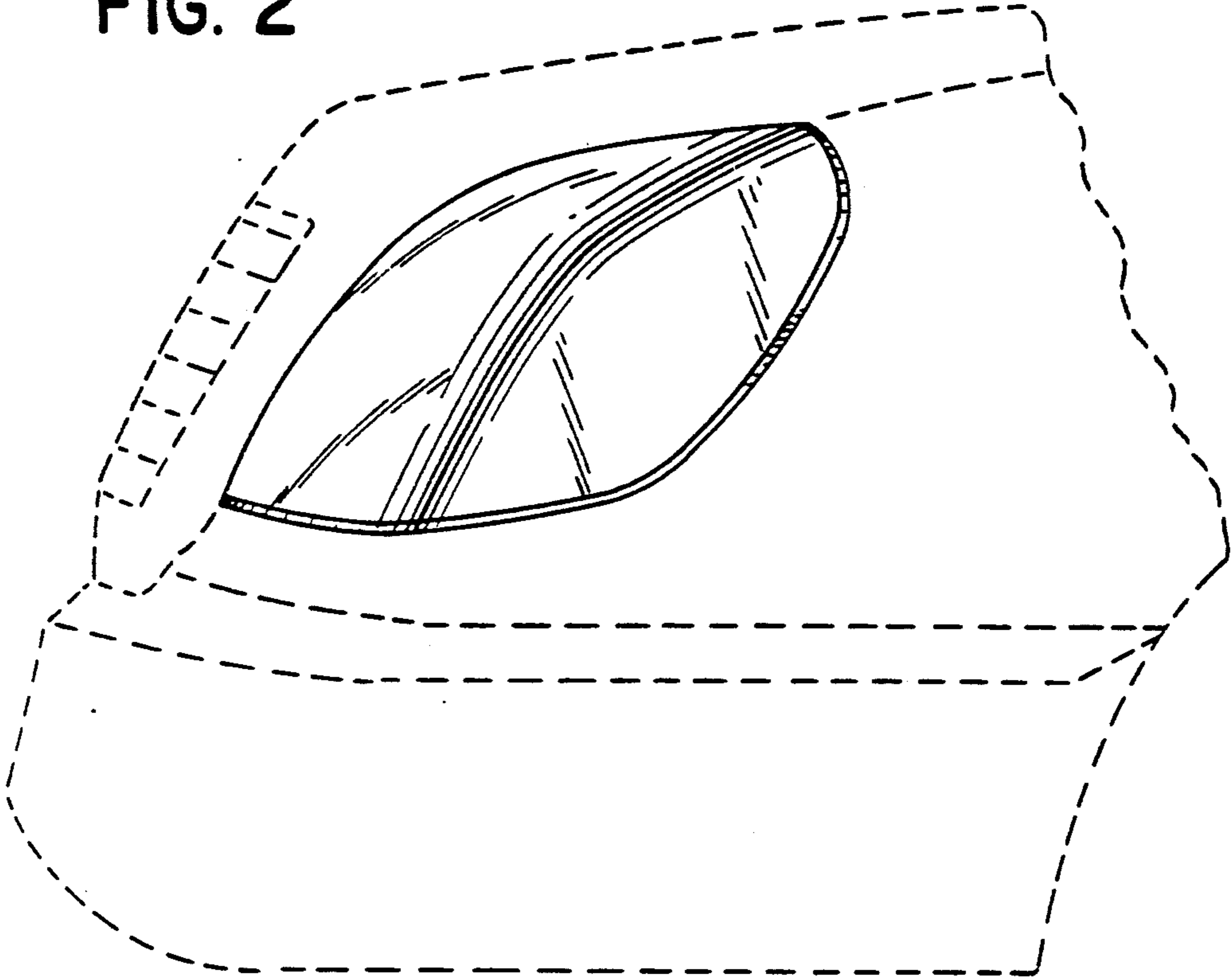

FIG. 3

