



US00D329039S

United States Patent [19]

[11] Patent Number: **Des. 329,039**

Struyk

[45] Date of Patent: **** Sep. 1, 1992**

[54] **PERSONAL WATERCRAFT PITOT TUBE**

Attorney, Agent, or Firm—Schroeder & Siegfried

[76] Inventor: **David A. Struyk**, 841 Hidden La.,
Excelsior, Minn. 55331

[57] **CLAIM**

The ornamental design for a personal watercraft pitot tube, as shown and described.

[**] Term: **14 Years**

DESCRIPTION

[21] Appl. No.: **615,632**

FIG. 1 is a top perspective view of a personal watercraft pitot tube showing my new design;

[22] Filed: **Nov. 19, 1990**

FIG. 2 is a side elevational view thereof, the opposite side view being a mirror image of that shown, the broken lines are for illustrative purposes only;

[52] U.S. Cl. **D12/317; D21/230**

FIG. 3 is a front elevational view thereof;

[58] Field of Search **D12/317, 318; 73/182;**

FIG. 4 is a top plan view thereof;

D21/230

FIG. 5 is a rear elevational view thereof;

[56] **References Cited**

U.S. PATENT DOCUMENTS

1,869,974	8/1932	Masters	73/182
3,082,623	3/1963	Bosland	73/182
3,084,543	4/1963	Finkl et al.	73/182
3,181,356	5/1965	Carpenter	73/182
3,217,535	11/1965	Taylor et al.	73/182
4,070,909	1/1978	Carpenter	73/182
4,271,700	6/1981	Tschanz et al.	73/182
4,622,850	11/1986	Graffrig	73/182

FIG. 6 is a bottom plan view thereof;

FIG. 7 is a top perspective view of a second embodiment of the personal watercraft pitot tube;

FIG. 8 is a side elevational view of FIG. 7, the opposite side view being a mirror image of that shown;

FIG. 9 is a front elevational view of FIG. 7;

FIG. 10 is a top plan view of FIG. 7; and,

FIG. 11 is a rear elevational view of FIG. 7.

The bottom plan view of the second embodiment is identical to that shown in FIG. 6.

Primary Examiner—Kay H. Chin

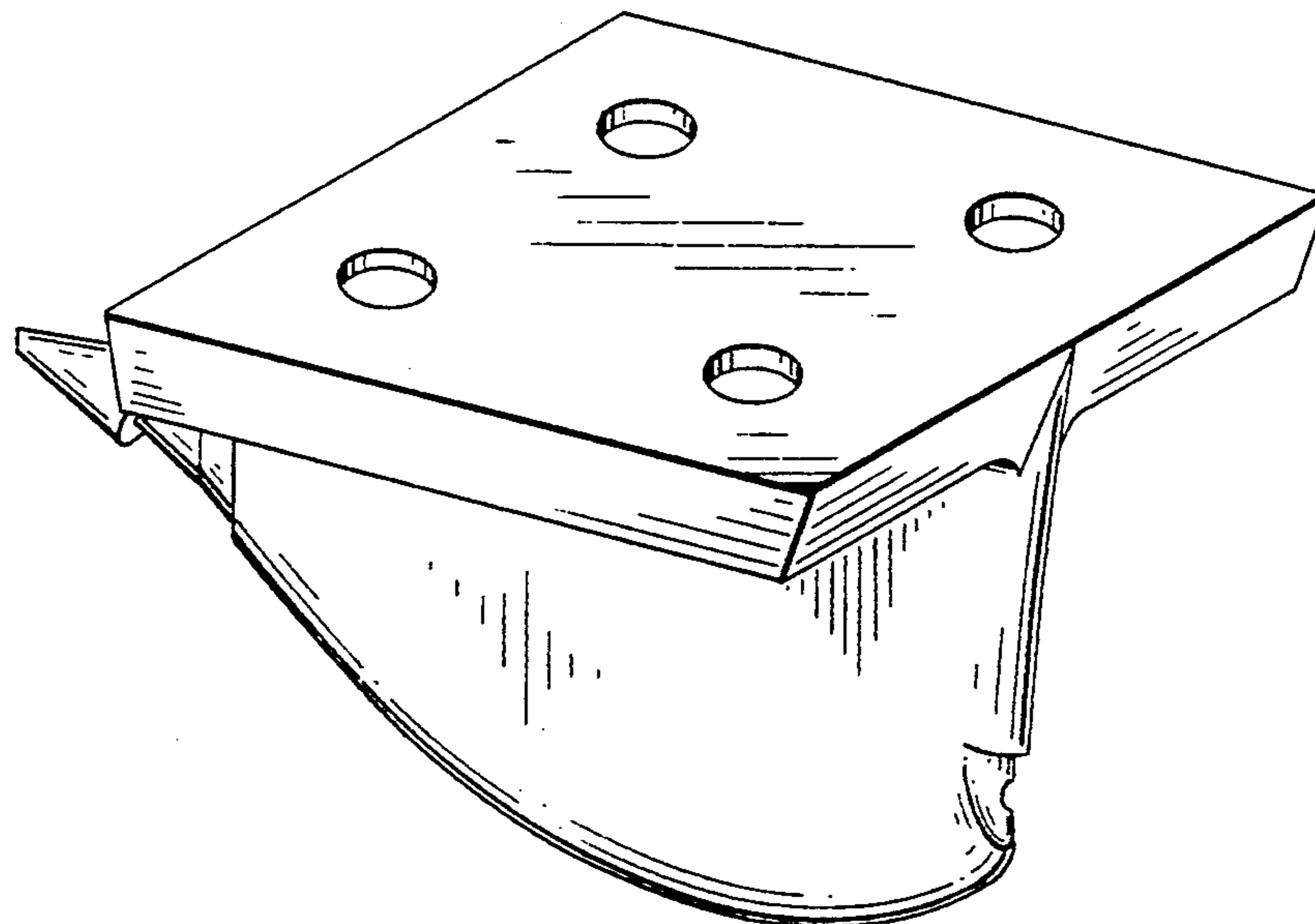

Fig.-1

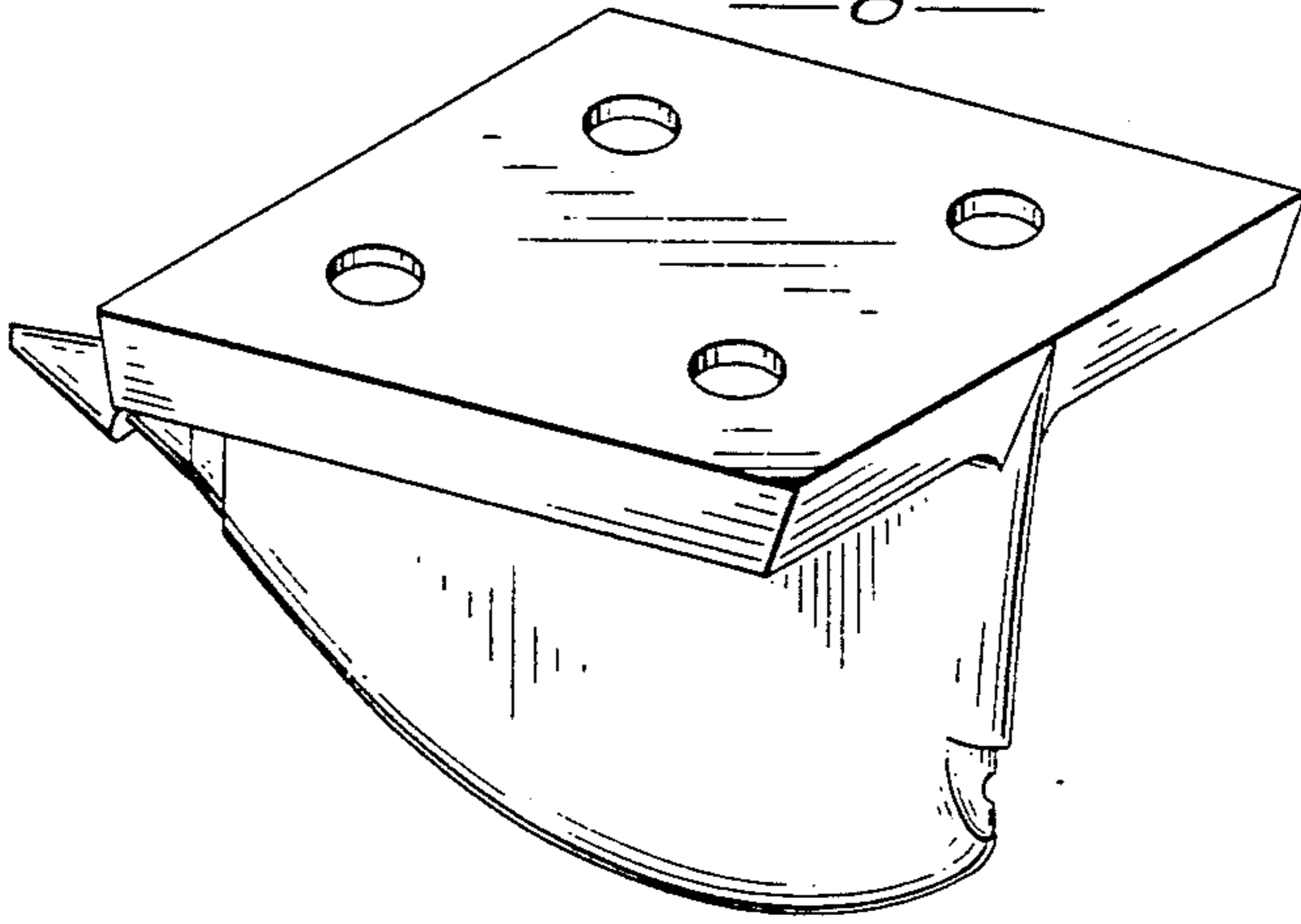

Fig.-2

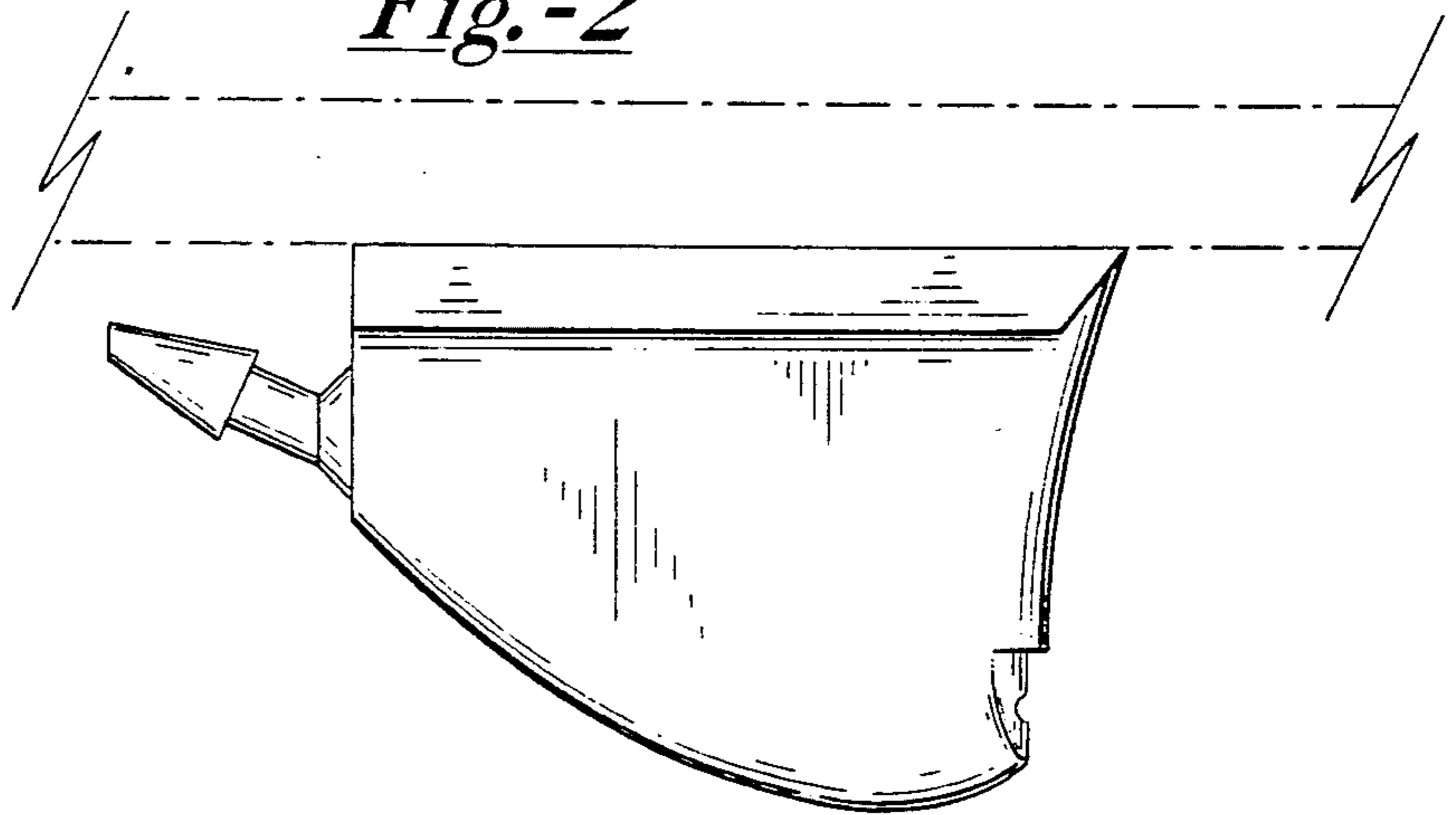

Fig.-3

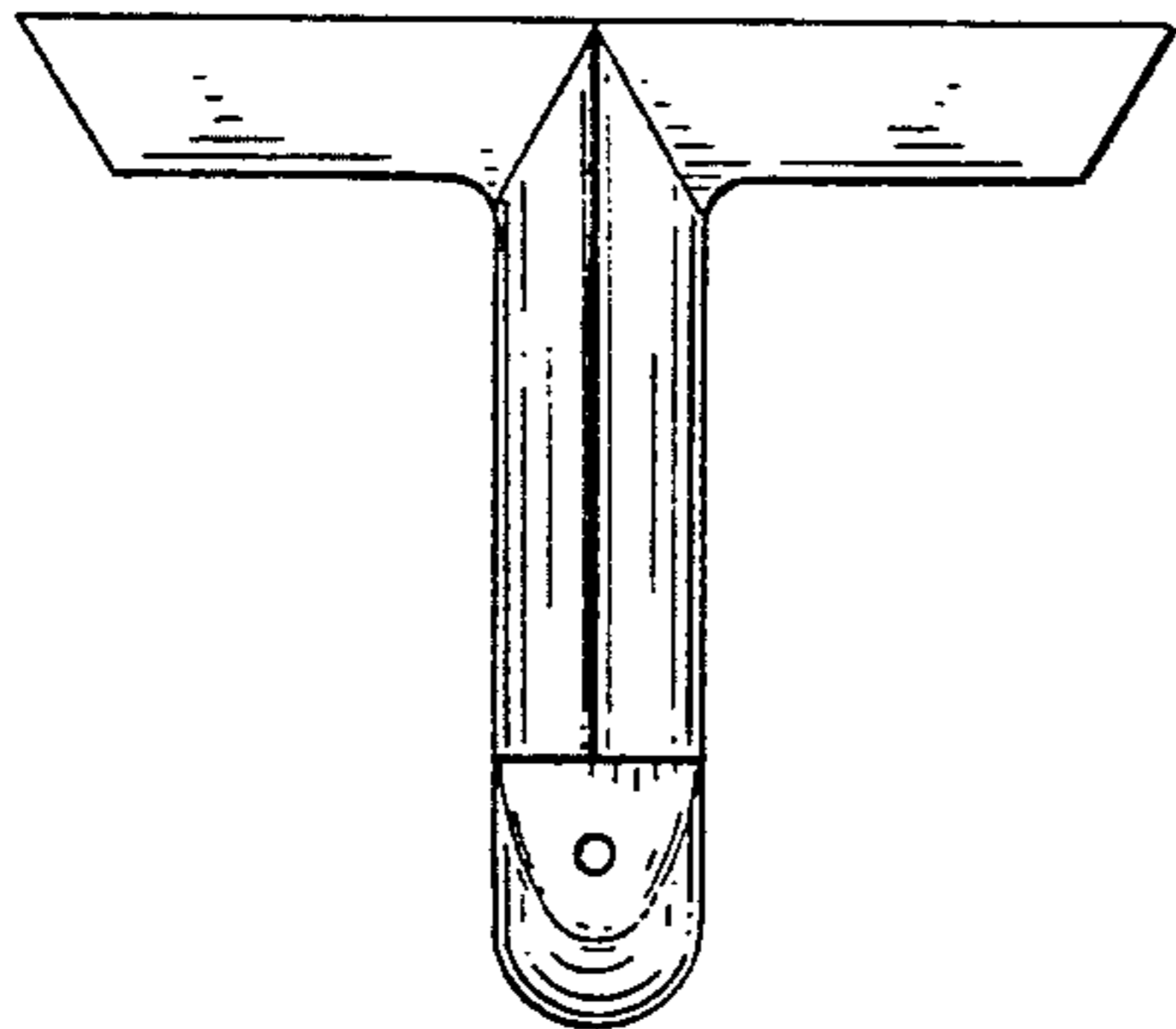

Fig.-4

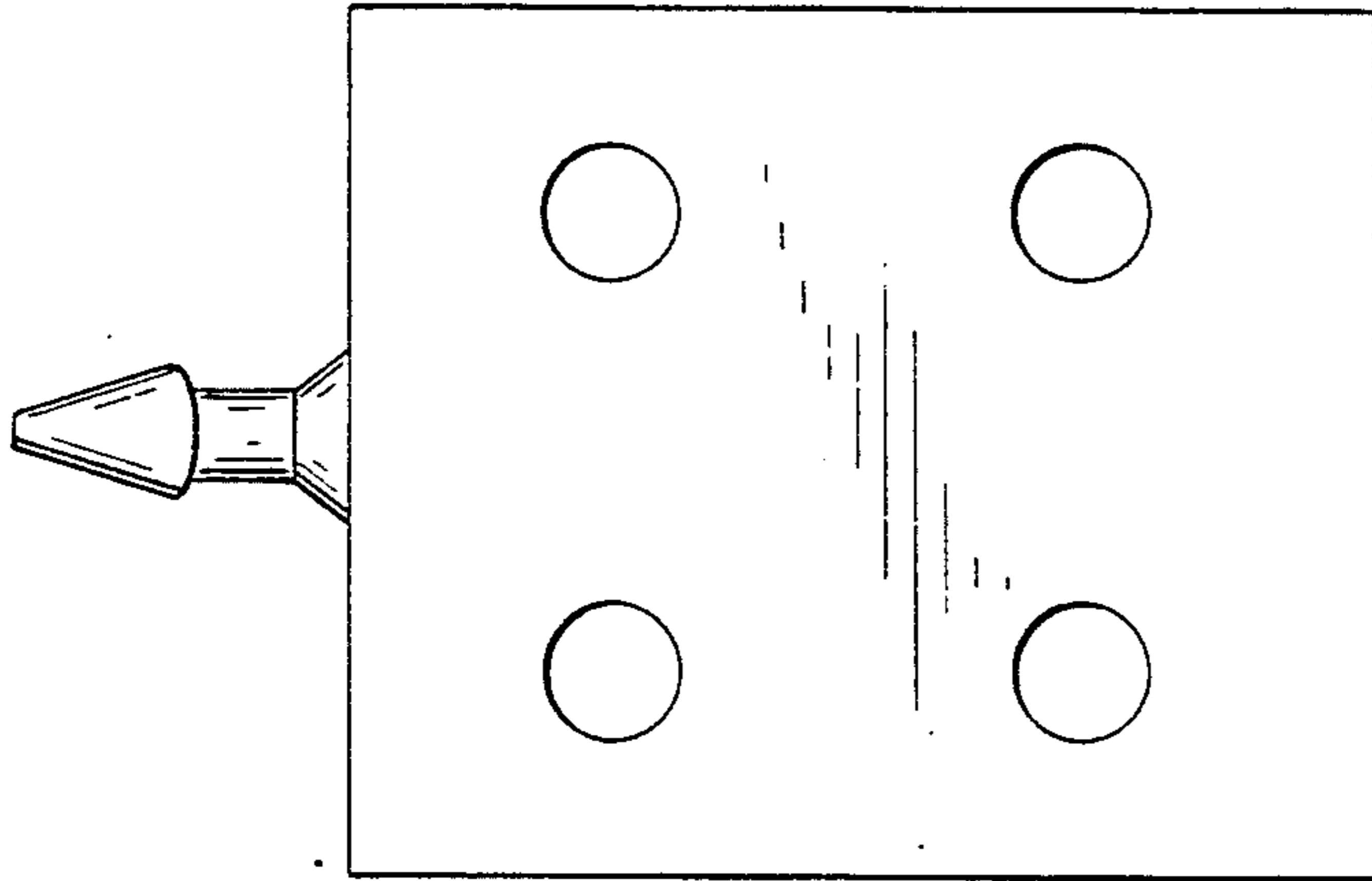

Fig.-5

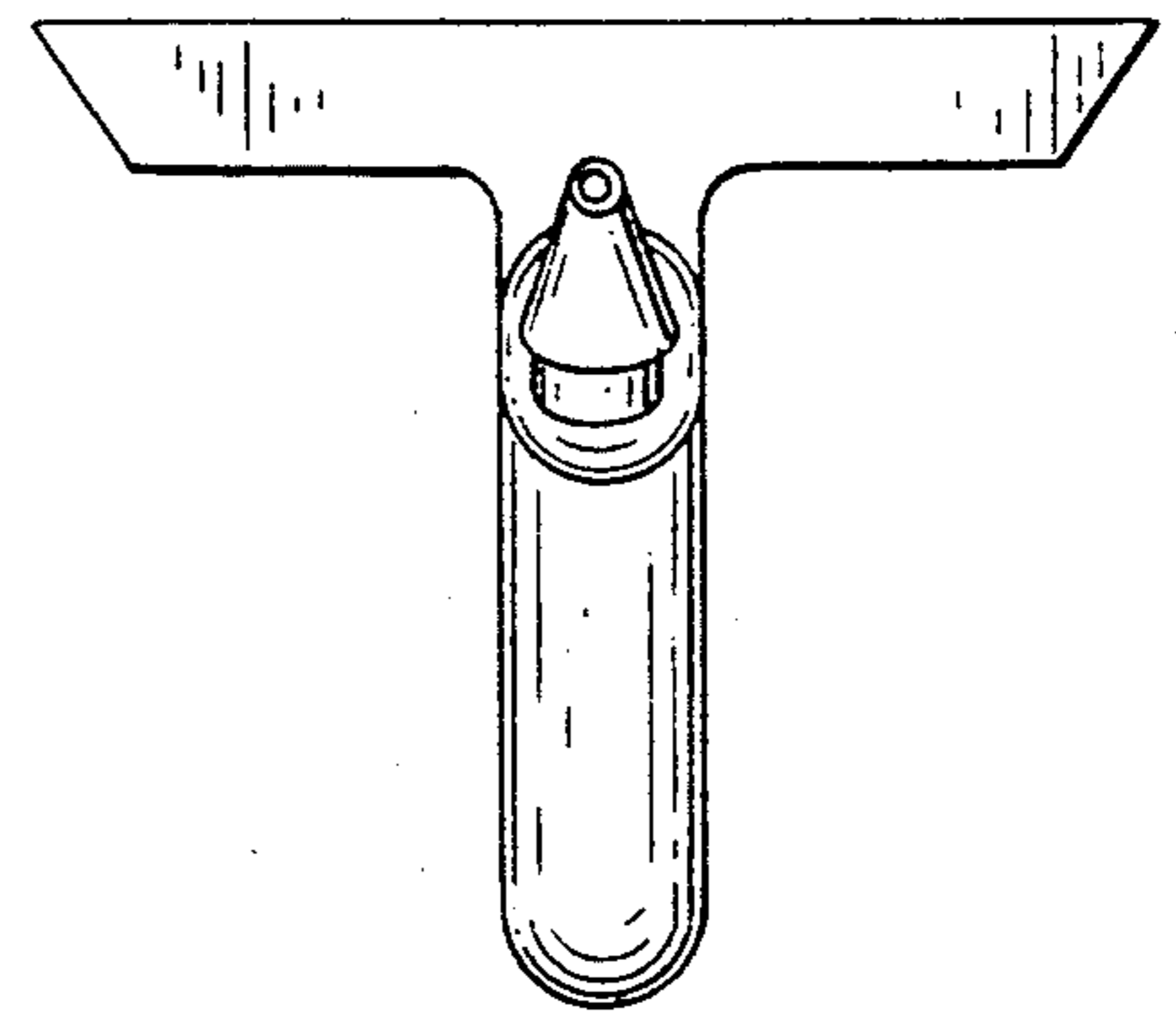
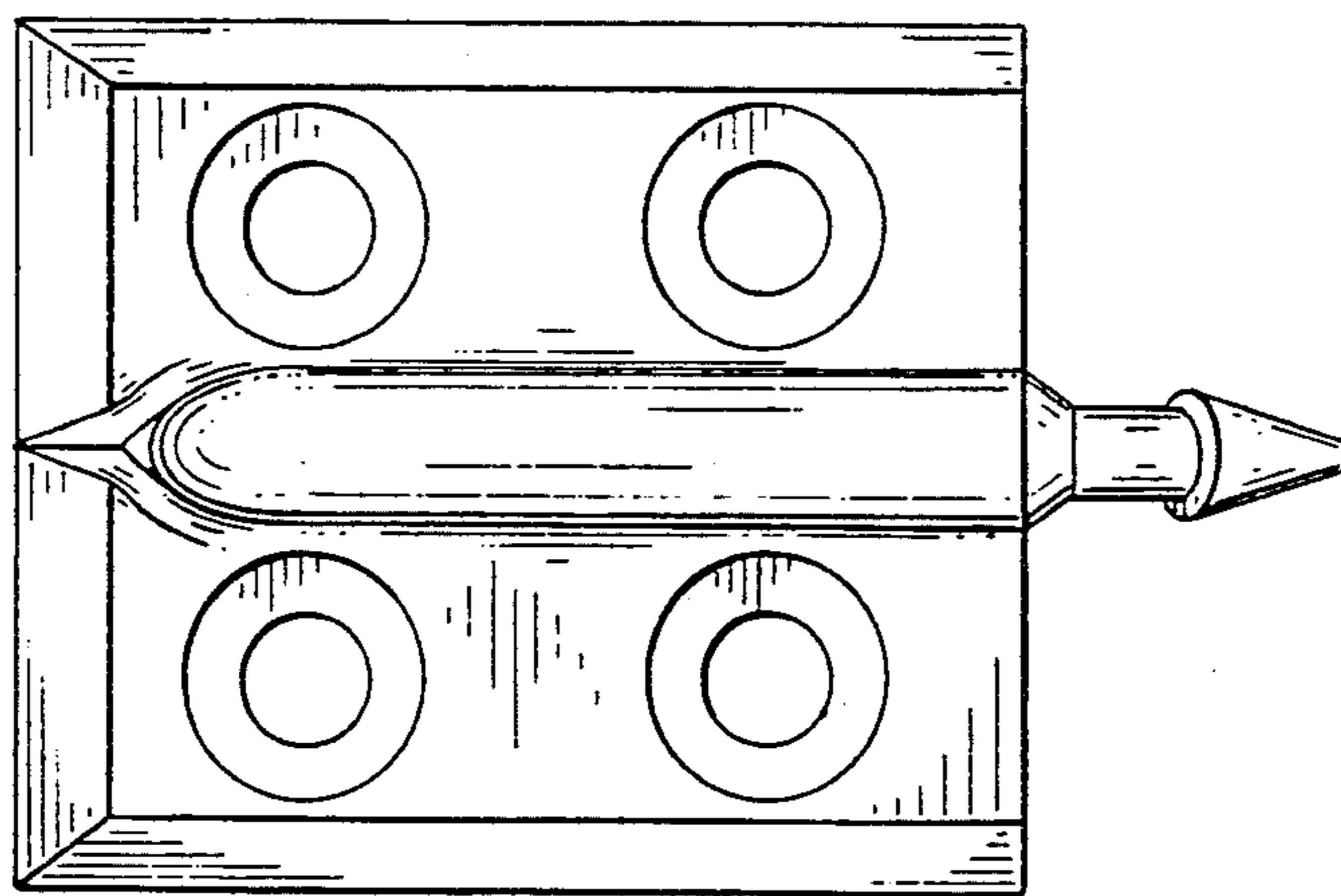

Fig.-6



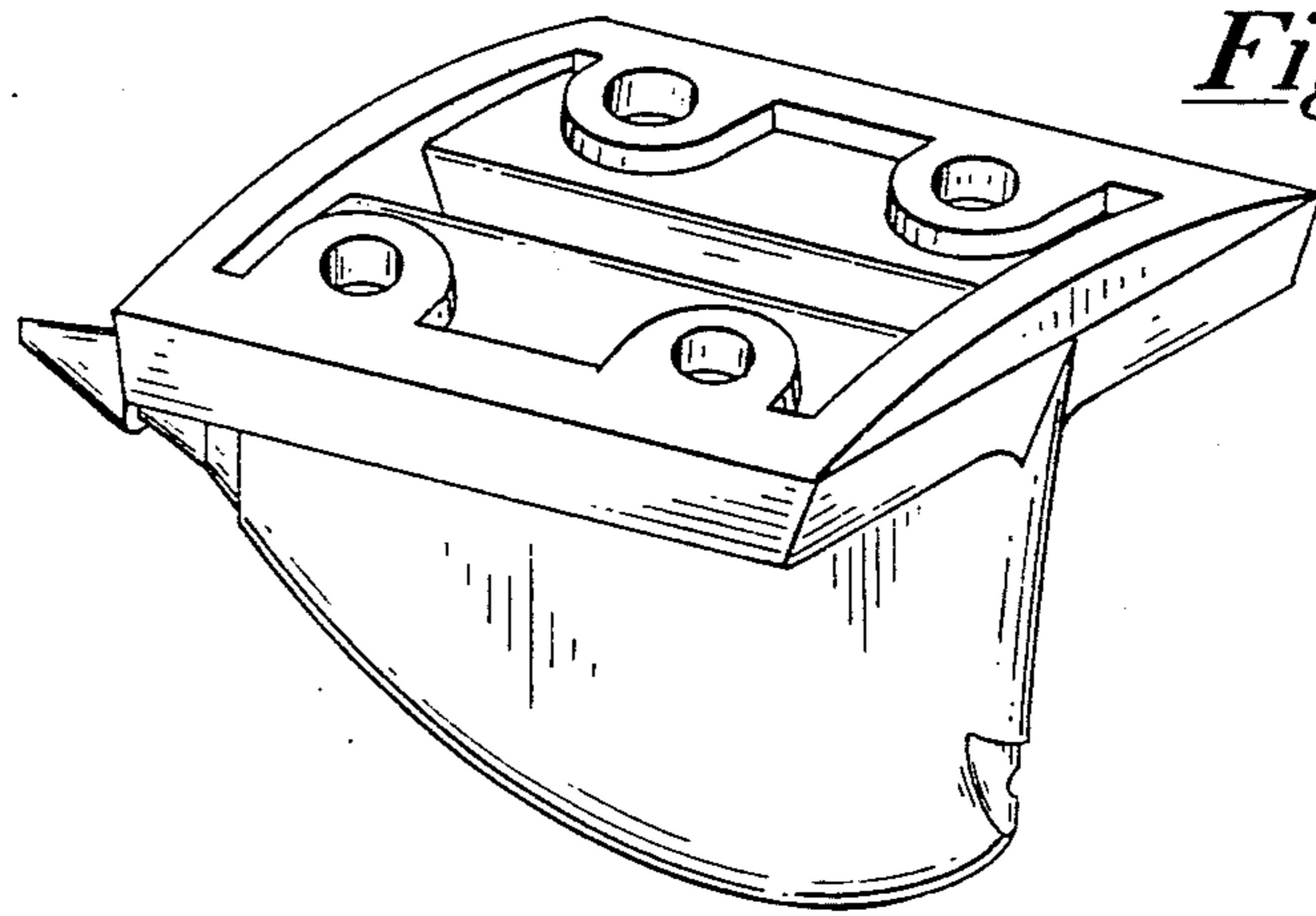

Fig.-7

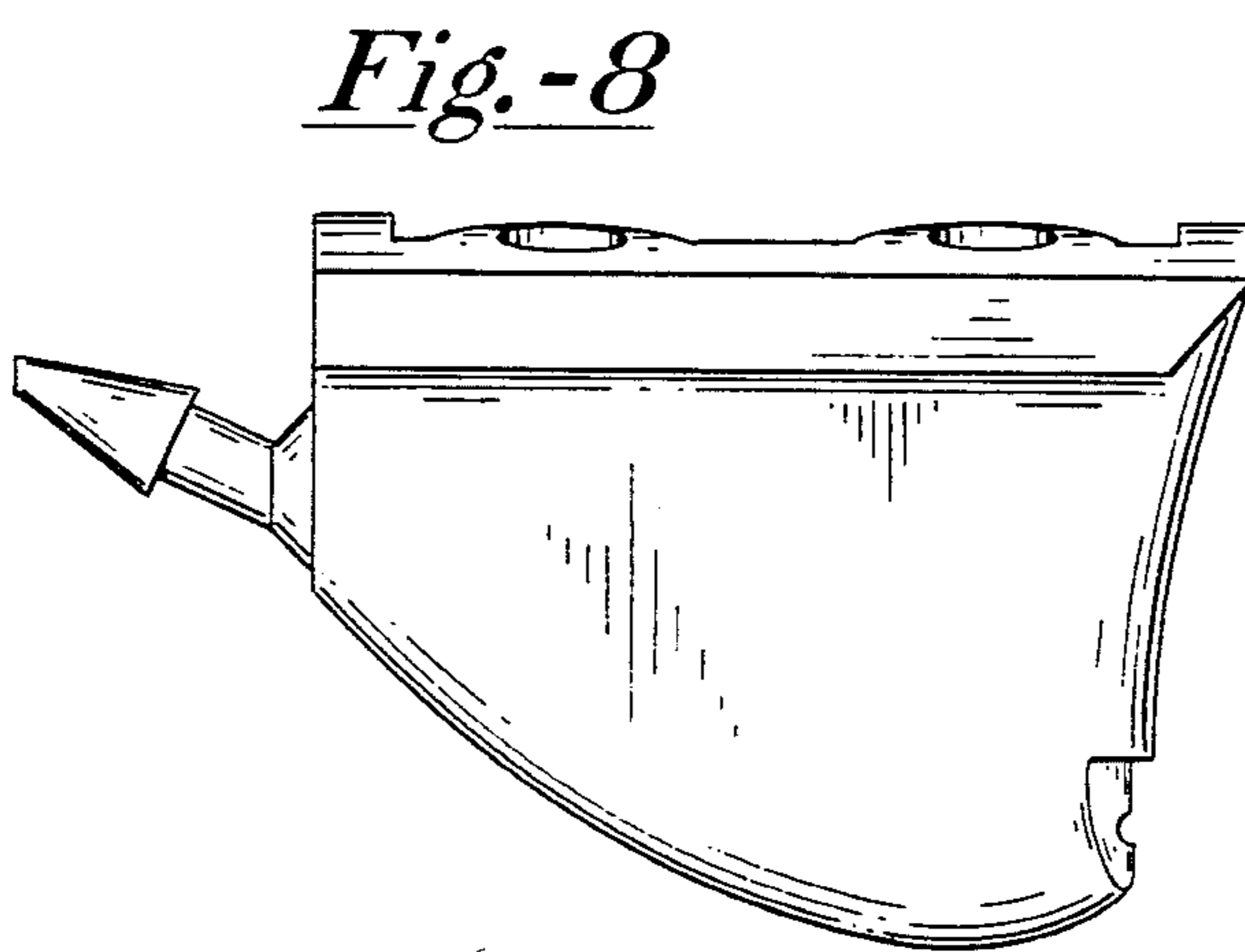

Fig.-8

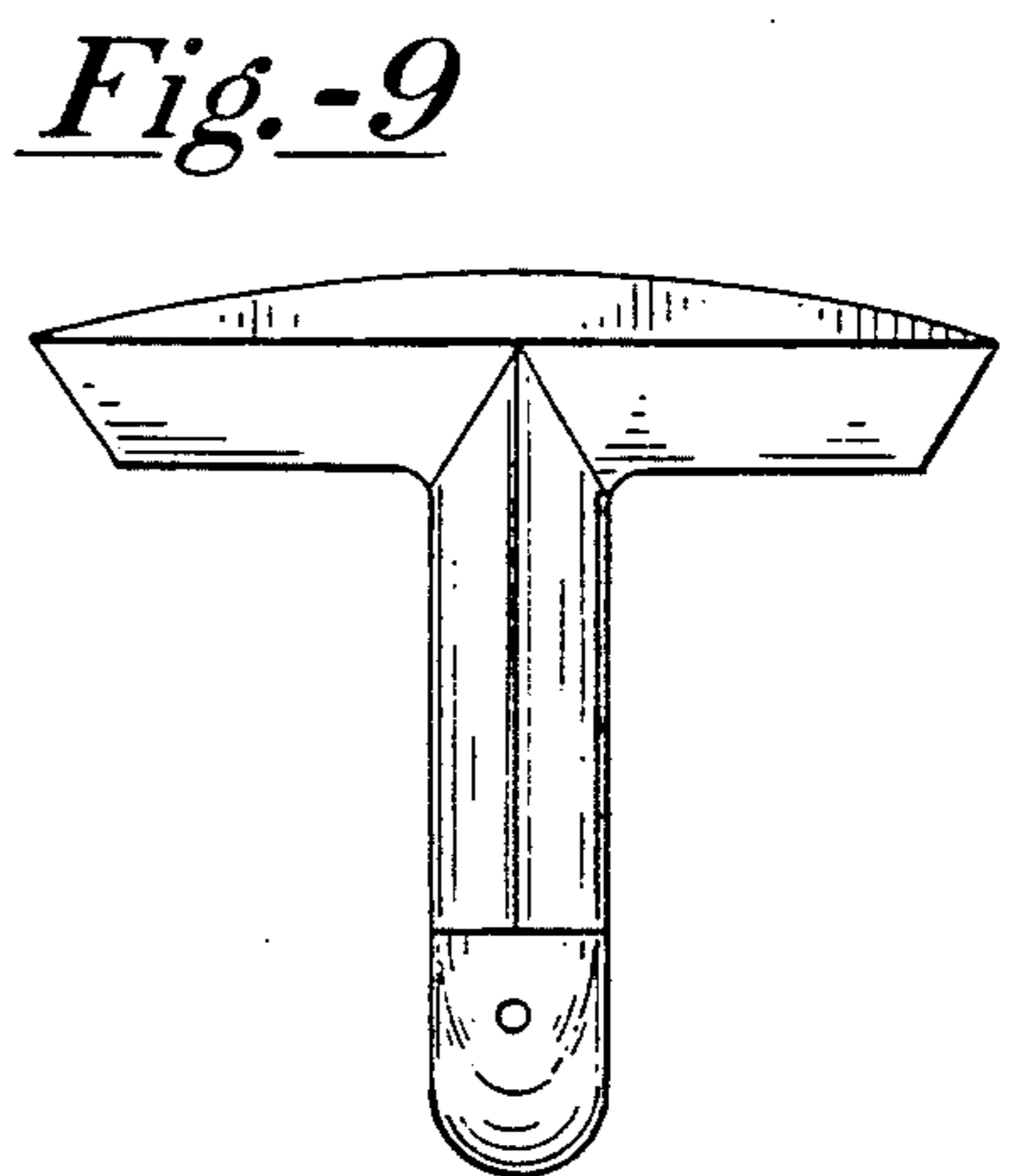

Fig.-9

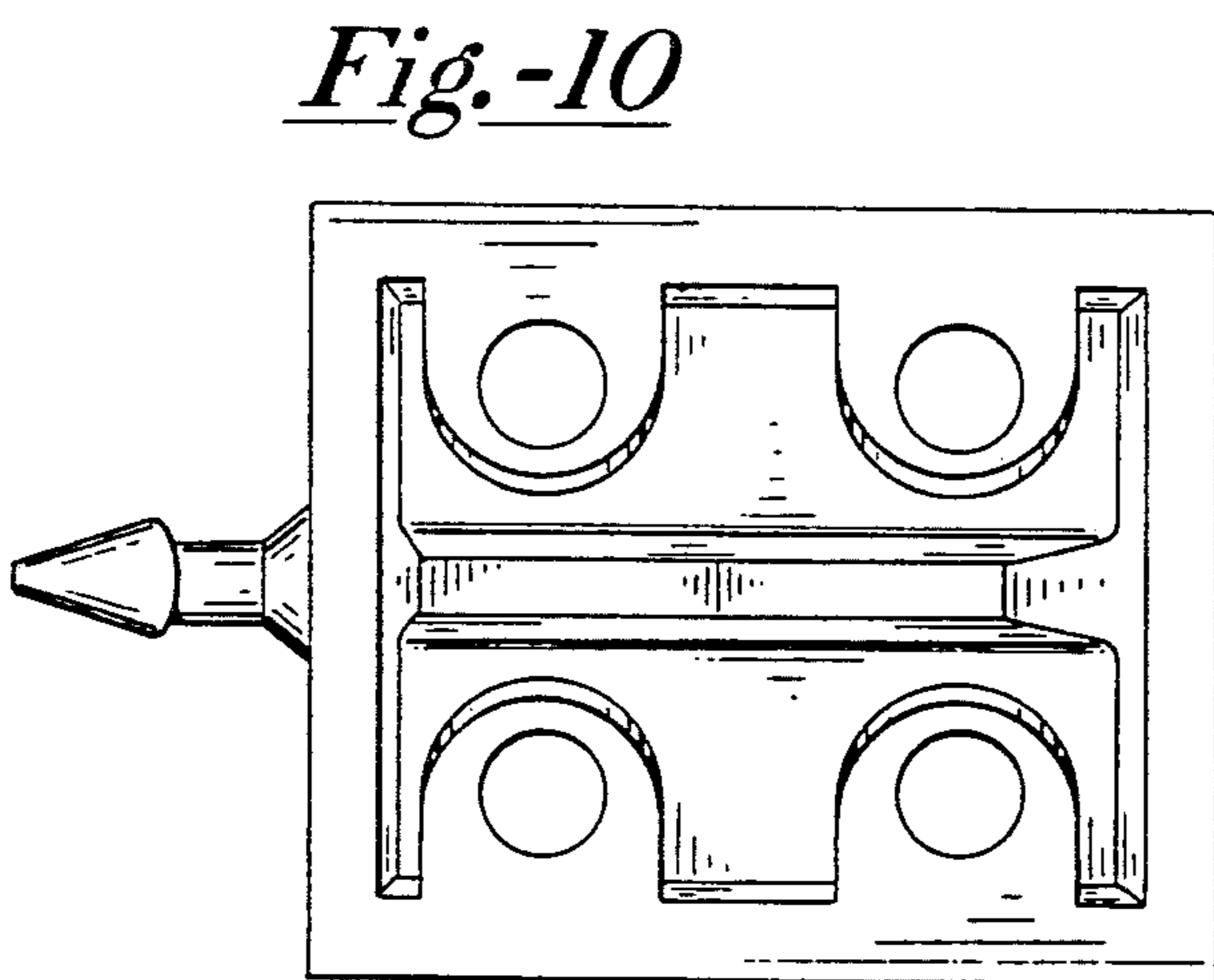

Fig.-10

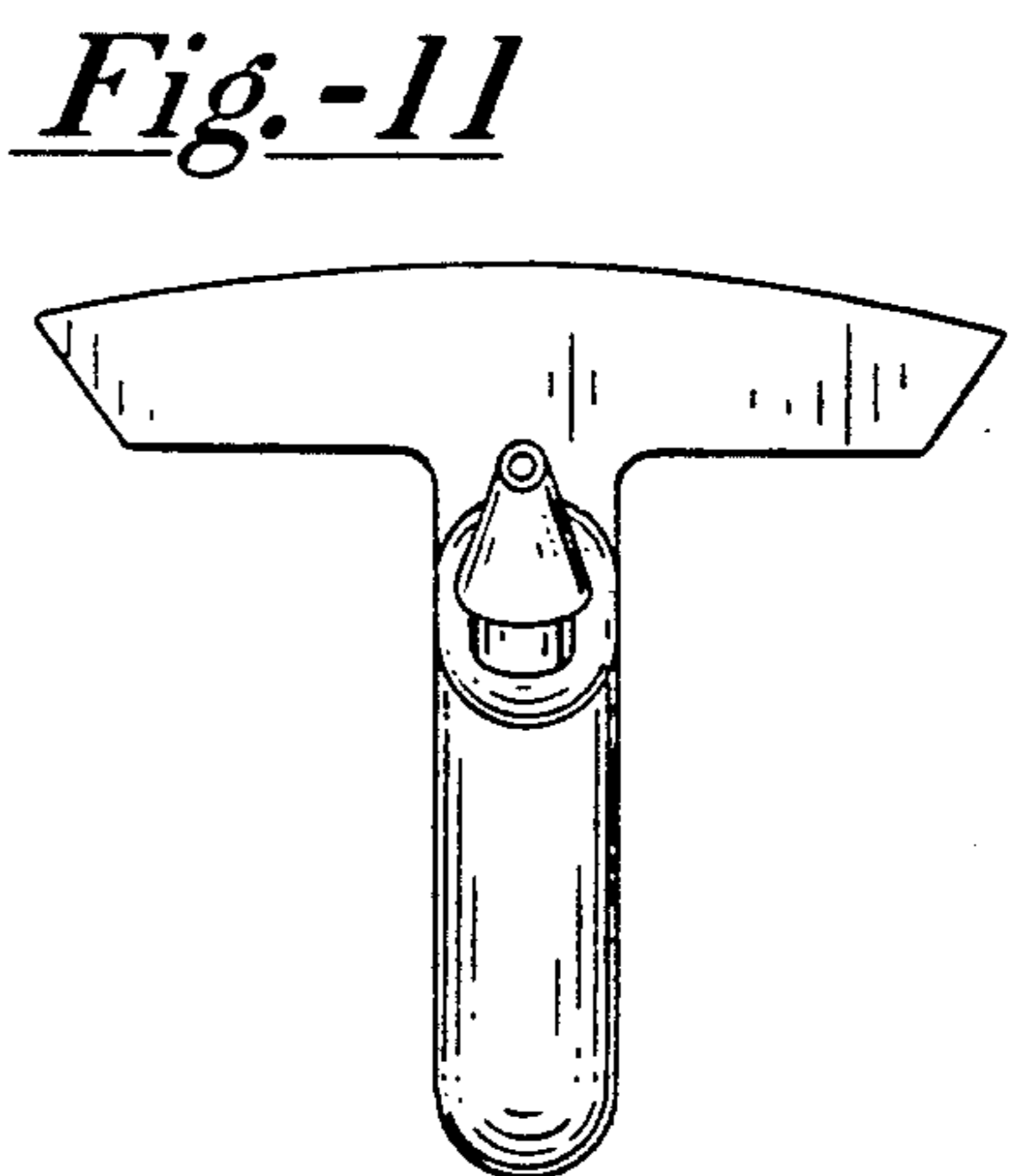

Fig.-11