



US00D329036S

United States Patent [19]
Yoshigai

[11] **Patent Number: Des. 329,036**
[45] **Date of Patent: ** Sep. 1, 1992**

[54] **BICYCLE CANTILEVER BRAKE**

[75] **Inventor: Kenichi Yoshigai, Osaka, Japan**
[73] **Assignee: Yoshigai Kikai Kinzoku Co., Ltd., Osaka, Japan**
[**] **Term: 14 Years**
[21] **Appl. No.: 517,600**
[22] **Filed: May 2, 1990**
[30] **Foreign Application Priority Data**

Nov. 20, 1989 [JP] Japan 1-42128
[52] **U.S. Cl. D12/179**
[58] **Field of Search D12/179; 188/24.11, 188/24.12, 24.21**

[56] **References Cited**

U.S. PATENT DOCUMENTS

4,766,979 8/1988 Nagano 188/24.12
4,768,623 9/1988 Nagano 188/24.12
4,960,187 10/1990 Chi 188/24.12

FOREIGN PATENT DOCUMENTS

0275022 1/1990 Fed. Rep. of Germany ... 188/24.11

OTHER PUBLICATIONS

American Bicyclist & Motorcyclist, Feb. 1990, pp. 8 & 53, The Modolo QT Tibet Cantilever Brake & MT-989A Cantilever Brake.
American Bicyclist & Motorcyclist, Feb. 1989, pp. 41 & 43, The 888 P Cantilever Brake, 886A, 884P and 982A Cantilever Brakes.

Primary Examiner—James M. Gandy
Assistant Examiner—Melody Brown
Attorney, Agent, or Firm—Sixbey, Friedman, Leedom & Ferguson

[57] **CLAIM**

The ornamental design for a bicycle cantilever brake, as shown.

DESCRIPTION

FIG. 1 is a front elevation view of a bicycle cantilever brake showing my new design;
FIG. 2 is a rear elevation view thereof;
FIG. 3 is a right side elevation view thereof;
FIG. 4 is a left side elevation view thereof;
FIG. 5 is a top plan view thereof; and,
FIG. 6 is a bottom plan view thereof.

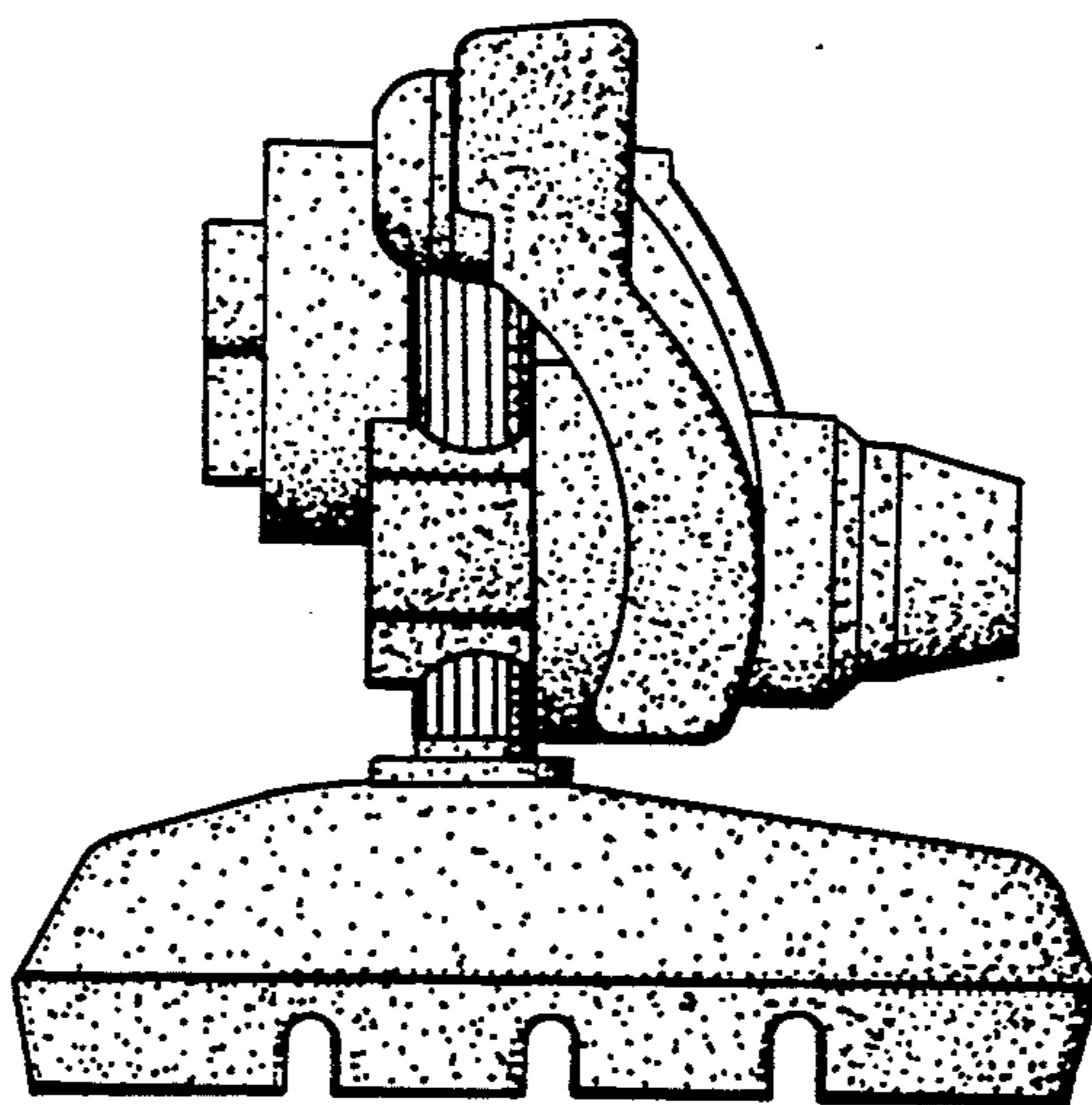

FIG.1

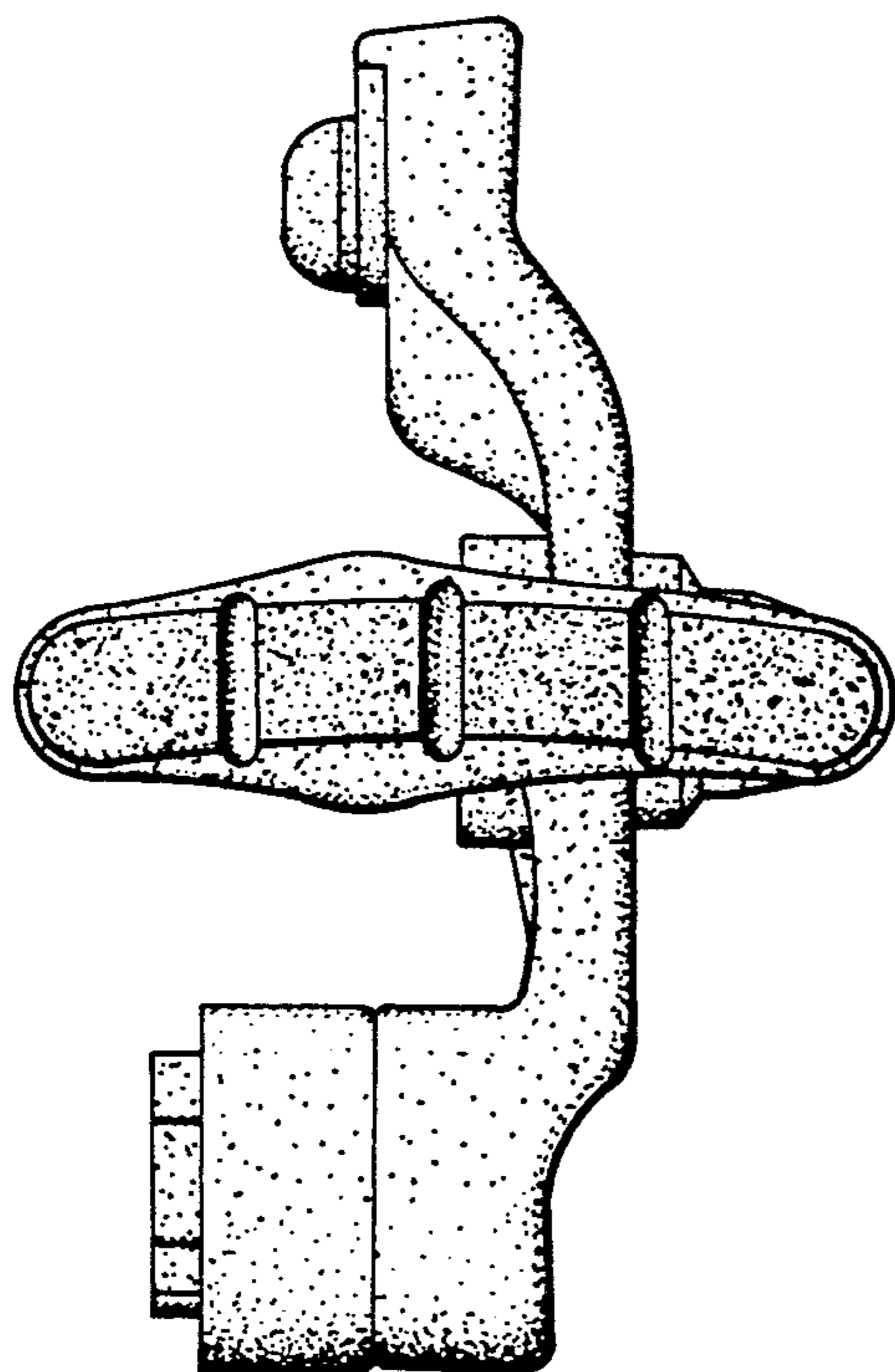

FIG.2

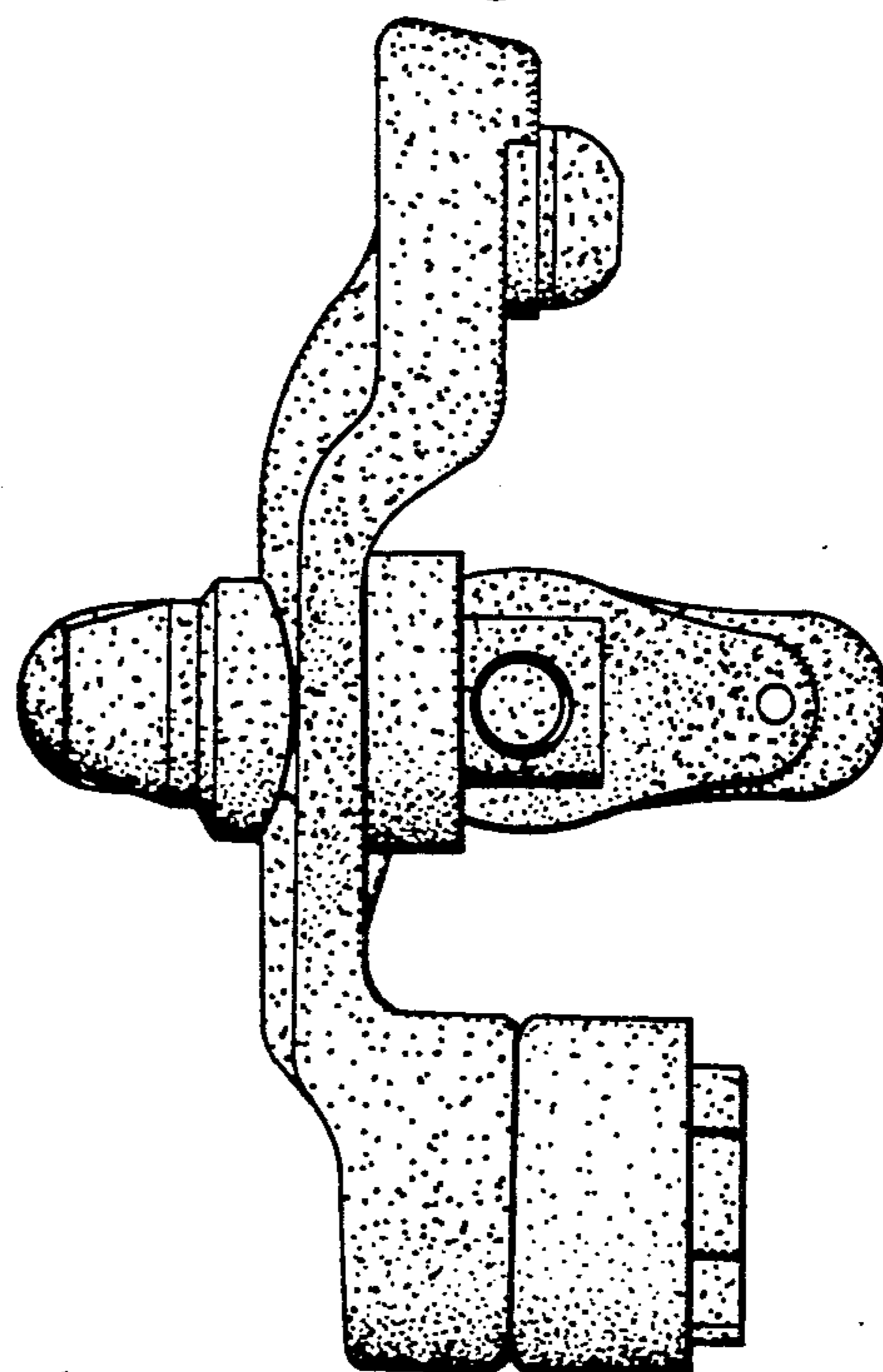

FIG.3

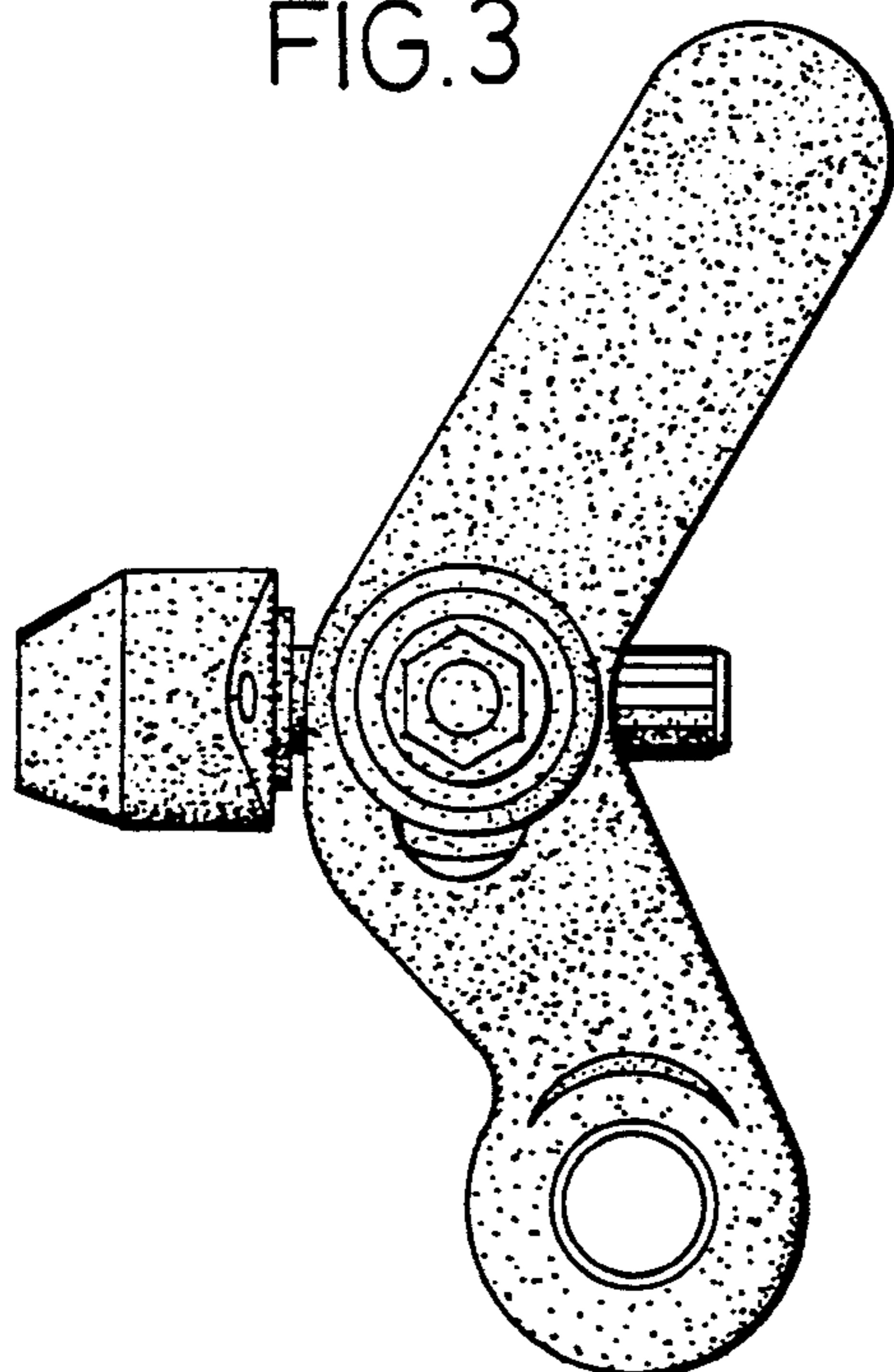

FIG.4

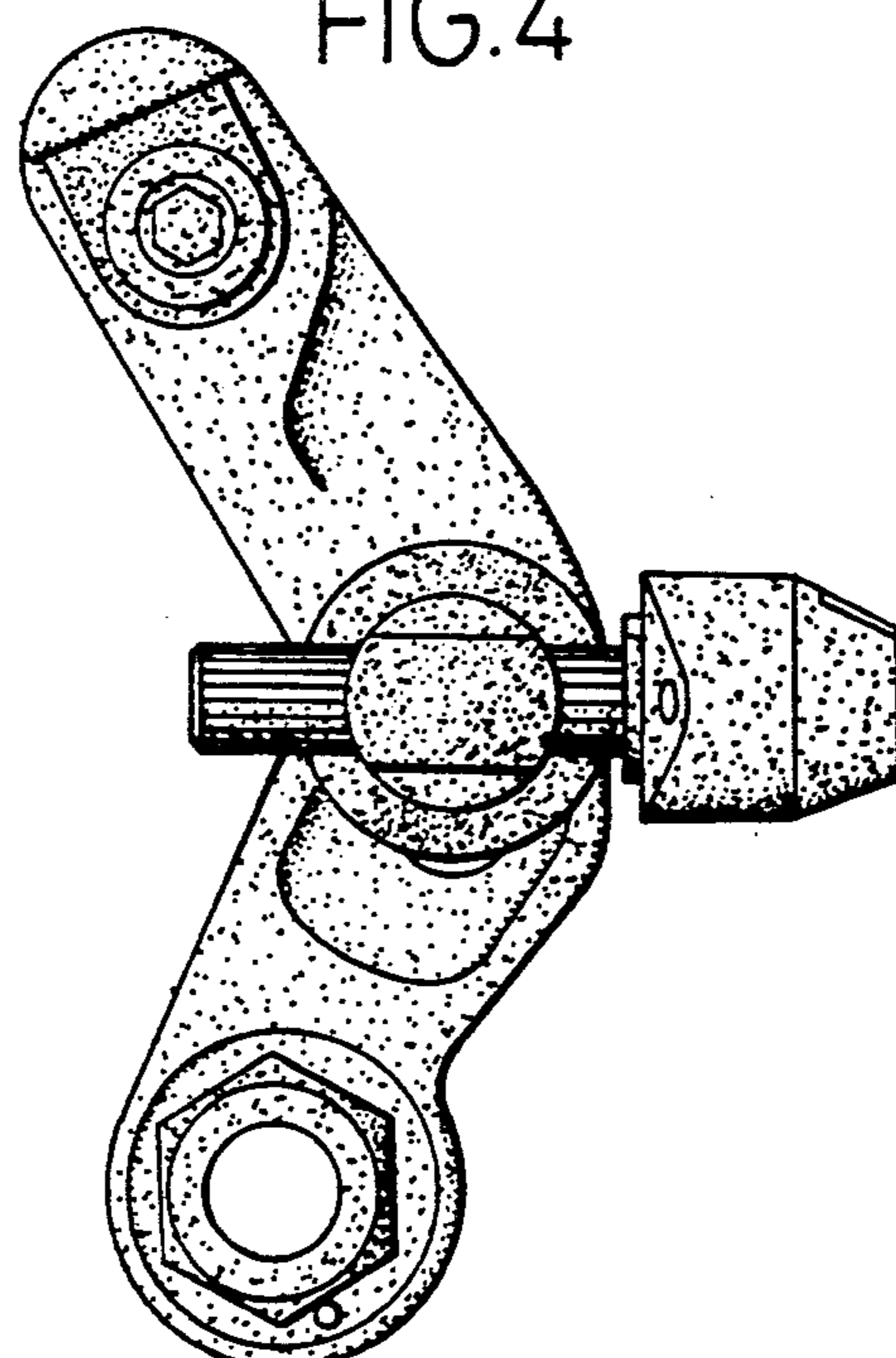

FIG. 5

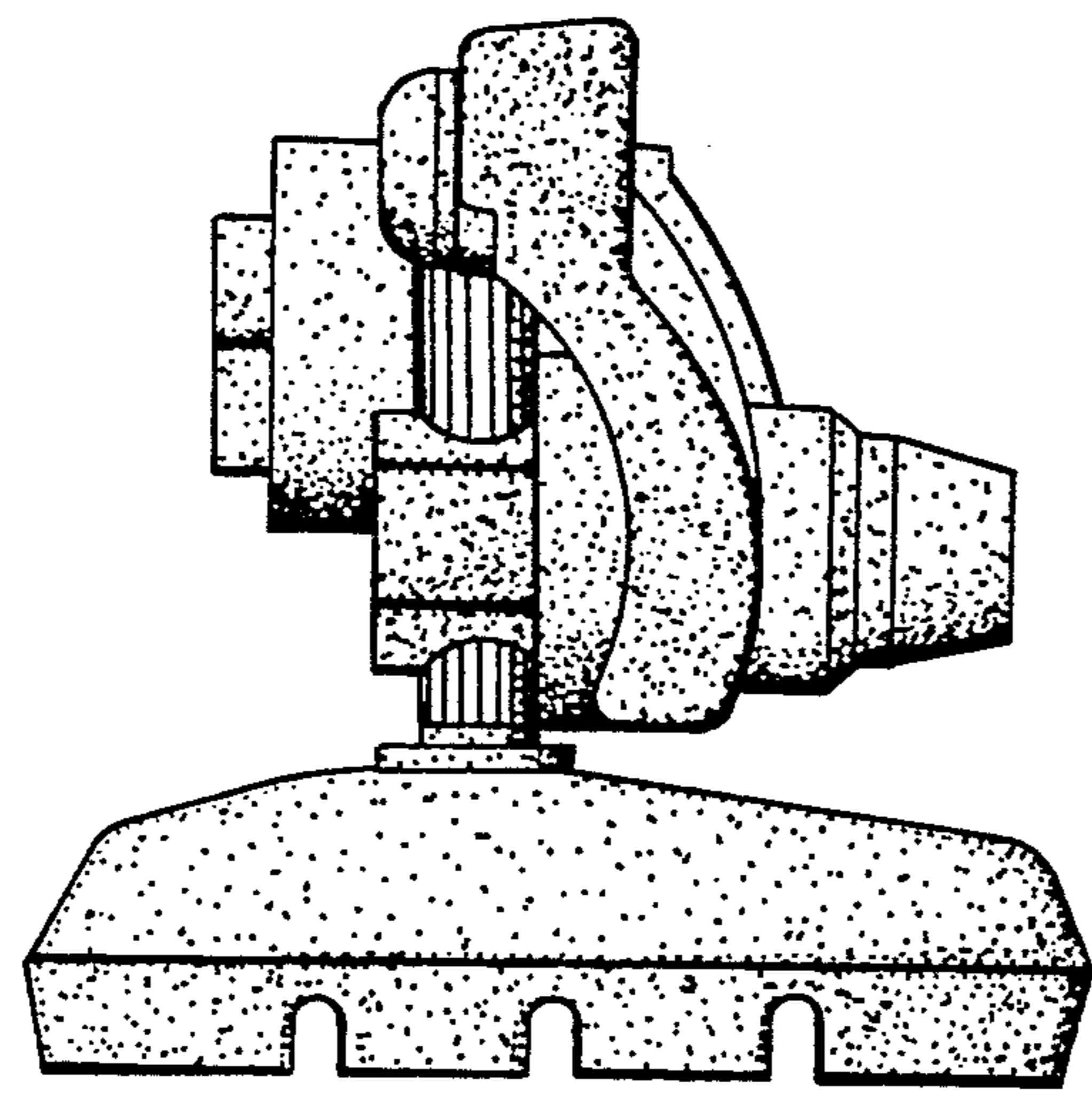

FIG. 6

