



US00D329035S

United States Patent [19]

Blackburn et al.

[11] Patent Number: **Des. 329,035**

[45] Date of Patent: **** Sep. 1, 1992**

[54] VEHICLE ATTACHED BICYCLE CARRIER

[75] Inventors: **James R. Blackburn**, Los Gatos;
Brandon A. Lee, San Mateo, both of Calif.

[73] Assignee: **Blackburn Designs, Inc.**, Campbell, Calif.

[**] Term: **14 Years**

[21] Appl. No.: **415,150**

[22] Filed: **Sep. 29, 1989**

[52] U.S. Cl. **D12/158**

[58] Field of Search **D12/158; 224/42.03 B, 224/30 R, 32 R, 32 A**

[56] References Cited

U.S. PATENT DOCUMENTS

- D. 292,567 11/1987 Douglas D12/158
- 4,394,948 7/1983 Graber 224/42.03 B
- 4,452,385 6/1984 Prosen 224/42.03 B

OTHER PUBLICATIONS

Bike Nashbar, Christmas 1988, p. 44, Atkins Graber guardian bicycle carrier.

American Bicyclist & Motorcyclist, Jan. 1987, p. 15, Amerpro bicycle carrier.

Primary Examiner—James M. Gandy

Assistant Examiner—Melody Brown

Attorney, Agent, or Firm—Rosenblum, Parish & Isaacs

[57] CLAIM

The ornamental design for a vehicle attached bicycle carrier, as shown.

DESCRIPTION

FIG. 1 is a perspective view of a vehicle attached bicycle carrier showing our new design, it being understood that the straps are shown broken away for convenience of illustration;

FIG. 2 is a side elevational view thereof, the opposite side being a mirror image of that shown; and,

FIG. 3 is a top plan view thereof.

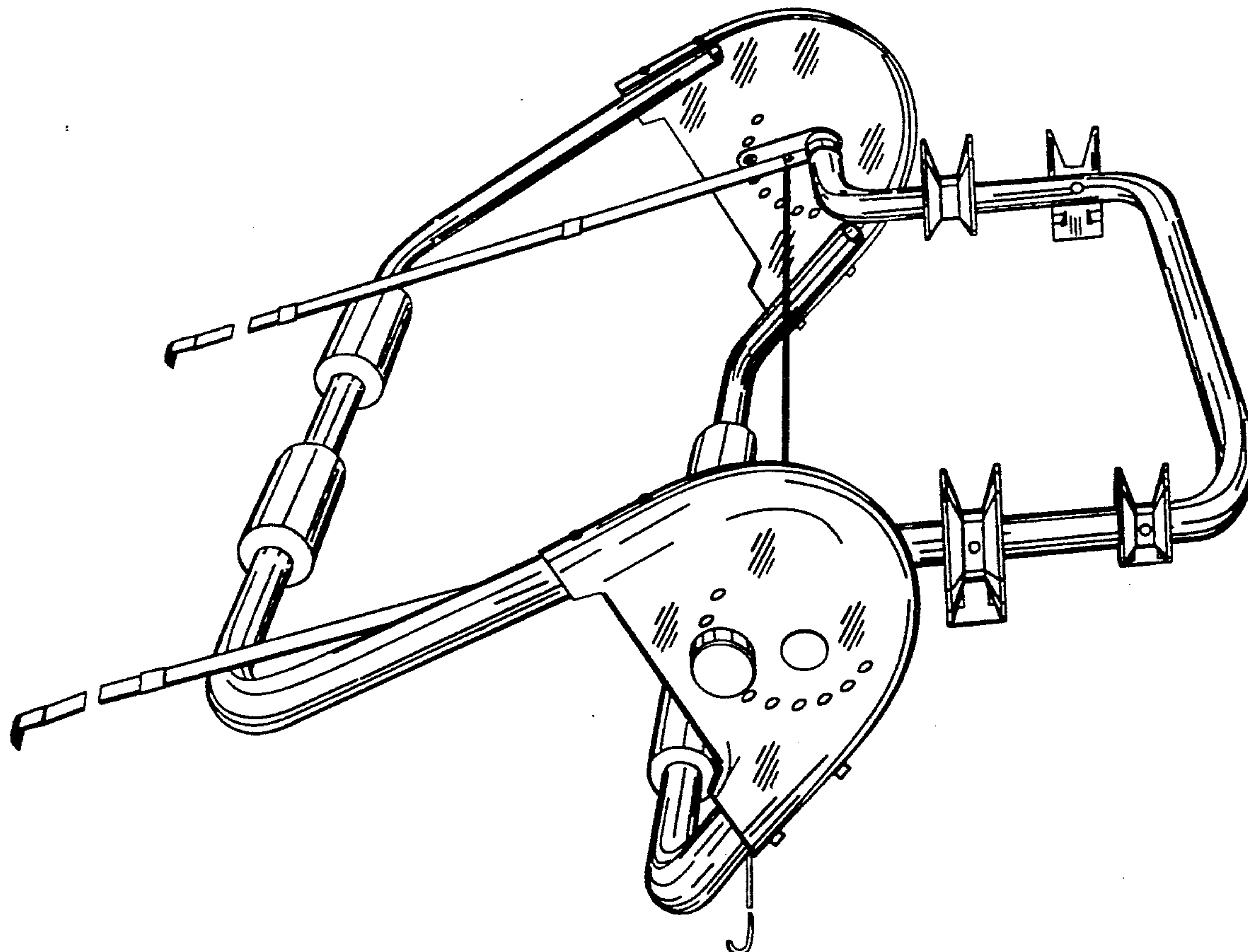

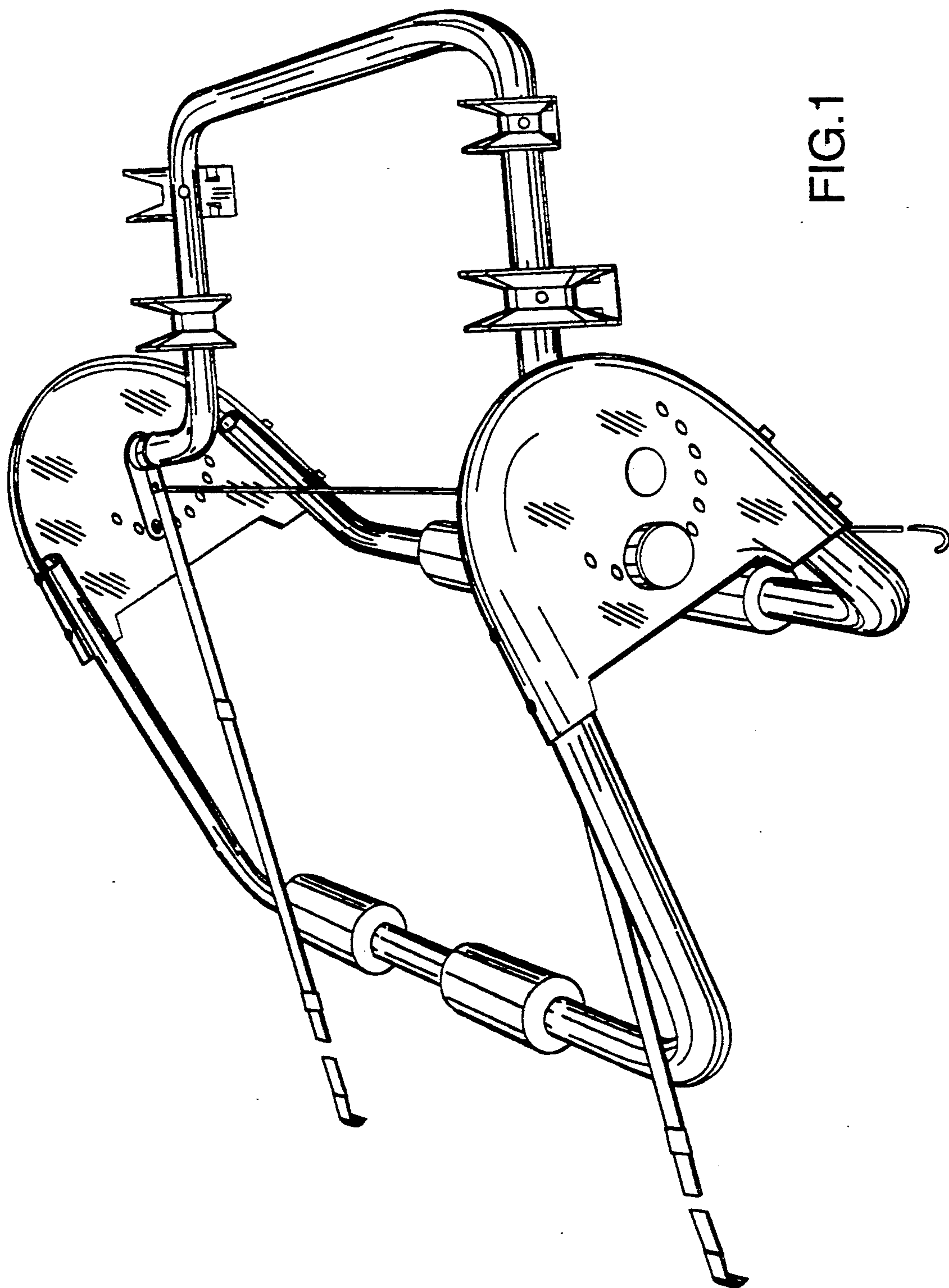

FIG. 1

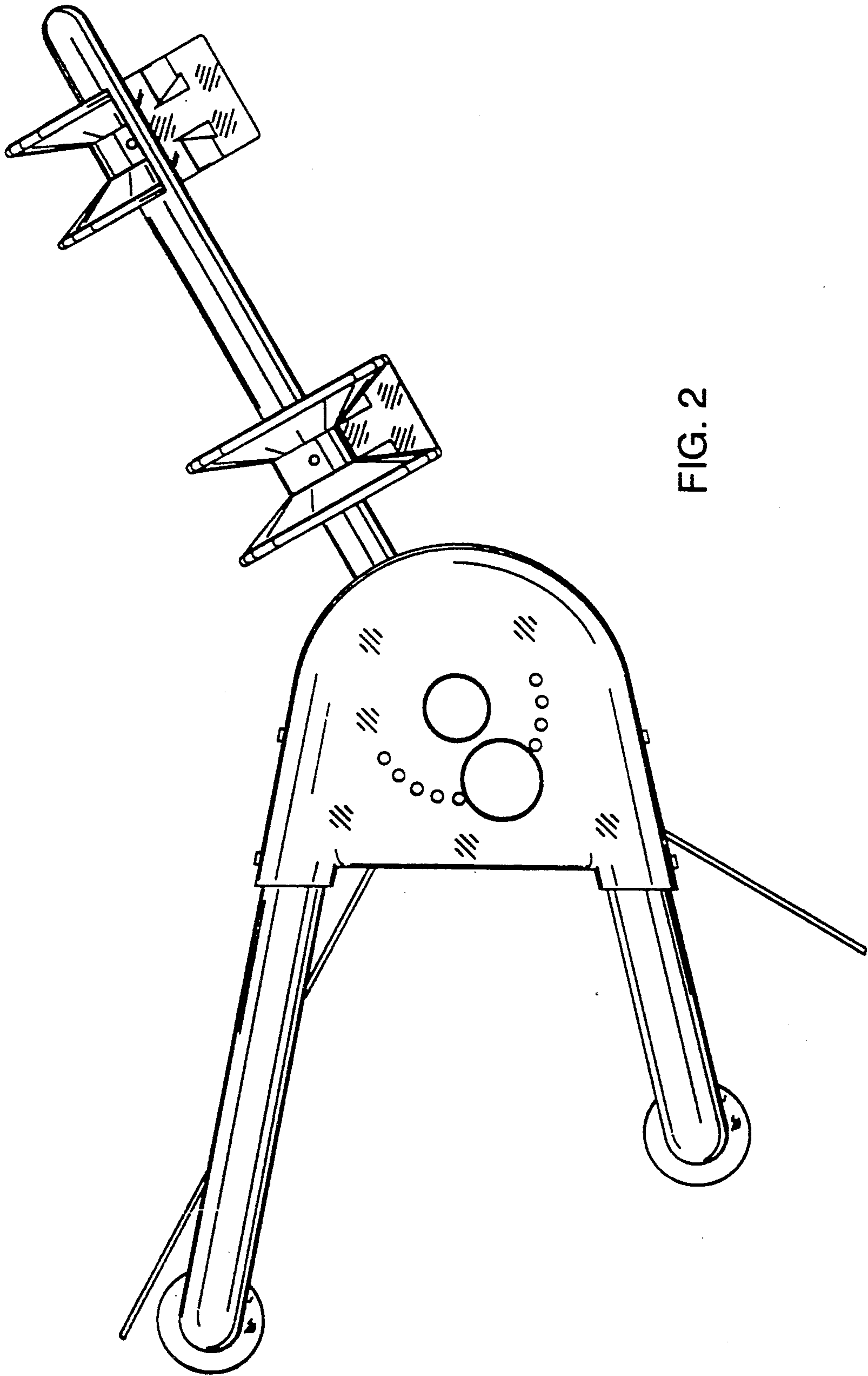

FIG. 2

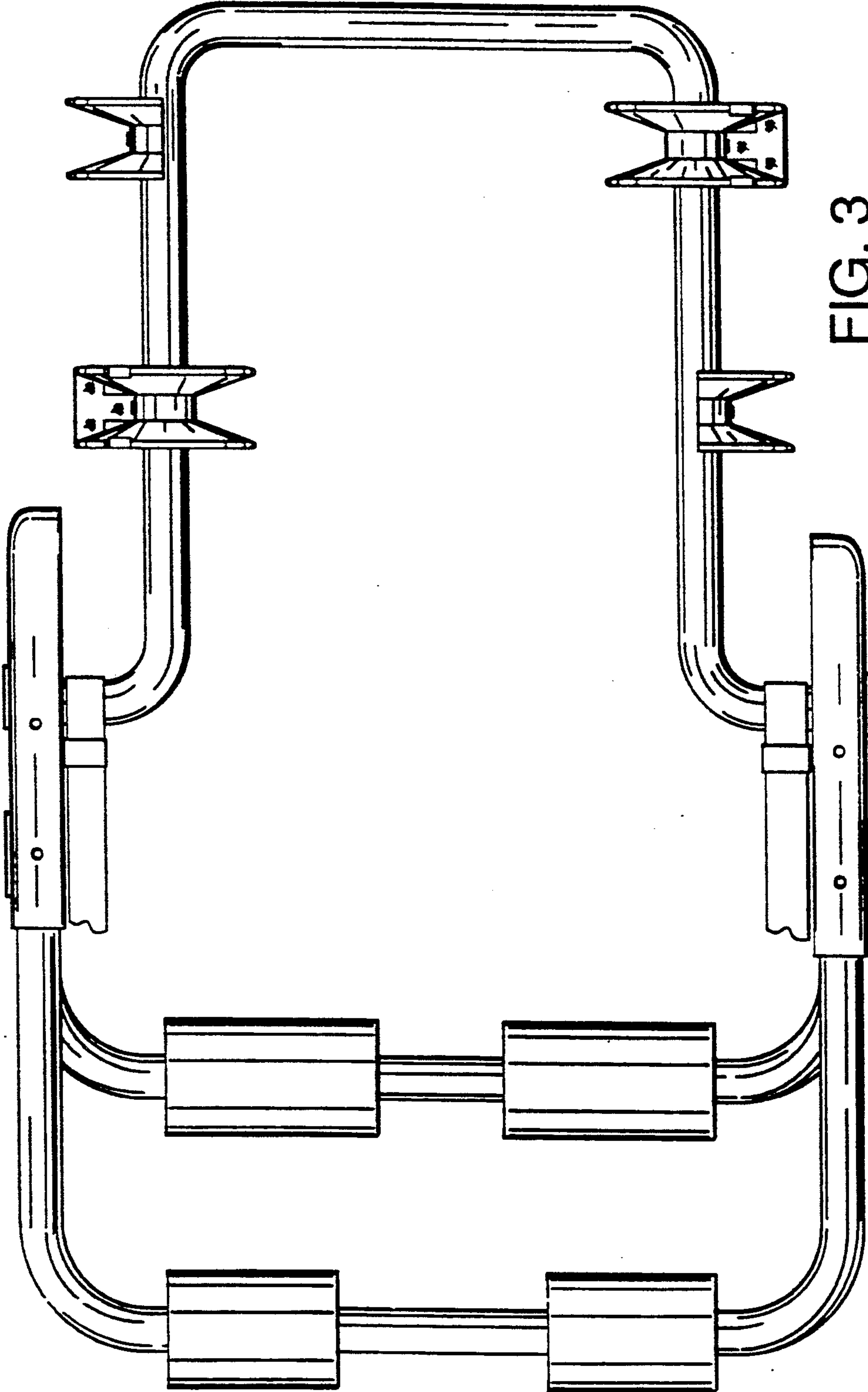

FIG. 3