



US00D328973S

# United States Patent [19]

[11] Patent Number: **Des. 328,973**

**Mankey**

[45] Date of Patent: **\*\* Sep. 1, 1992**

[54] **CAR CONSOLE**

[57] **CLAIM**

[75] Inventor: **Neal N. Mankey, Charlotte, N.C.**

The ornamental design for a car console, as shown and described.

[73] Assignee: **Allied Plastics, Inc., Gastonia, N.C.**

### DESCRIPTION

[\*\*] Term: **14 Years**

FIG. 1 is a rear perspective view of a car console showing my new design;

[21] Appl. No.: **632,328**

FIG. 2 is a side perspective view of the car console as shown in FIG. 1 with the lid to the rear compartment in its fully open position;

[22] Filed: **Dec. 21, 1990**

FIG. 3 is a top plan view of the car console as shown in FIG. 1;

[52] U.S. Cl. .... **D3/40**

FIG. 4 is a bottom plan view thereof;

[58] Field of Search ..... **D3/35, 40; D12/155; 224/42.11, 42.42, 273, 275, 327, 329**

FIG. 5 is a side elevational view thereof;

FIG. 6 is the opposite side elevational view thereof;

### [56] **References Cited**

#### **U.S. PATENT DOCUMENTS**

- D. 248,294 6/1978 McCutchen ..... D12/155
- D. 271,442 11/1983 Lehner ..... D3/40
- D. 285,216 8/1986 Roskvist ..... D3/35 X
- D. 307,355 1/1990 Page, Jr. .... D3/35 X

FIG. 7 is an end elevational view thereof as viewed in the direction of the arrows 7 in FIG. 6;

FIG. 8 is the opposite end elevational view thereof as viewed in the direction of the arrows 8 in FIG. 6; and,

FIG. 9 is a side elevational view of a car console showing an alternate embodiment of my new design, the modification being the omission of the support leg.

*Primary Examiner*—Louis S. Zarfes

The broken line showing of a car seat, parking brake and seat belt is for illustrative purposes only and forms no part of the claimed design.

*Attorney, Agent, or Firm*—Bell, Seltzer, Park & Gibson

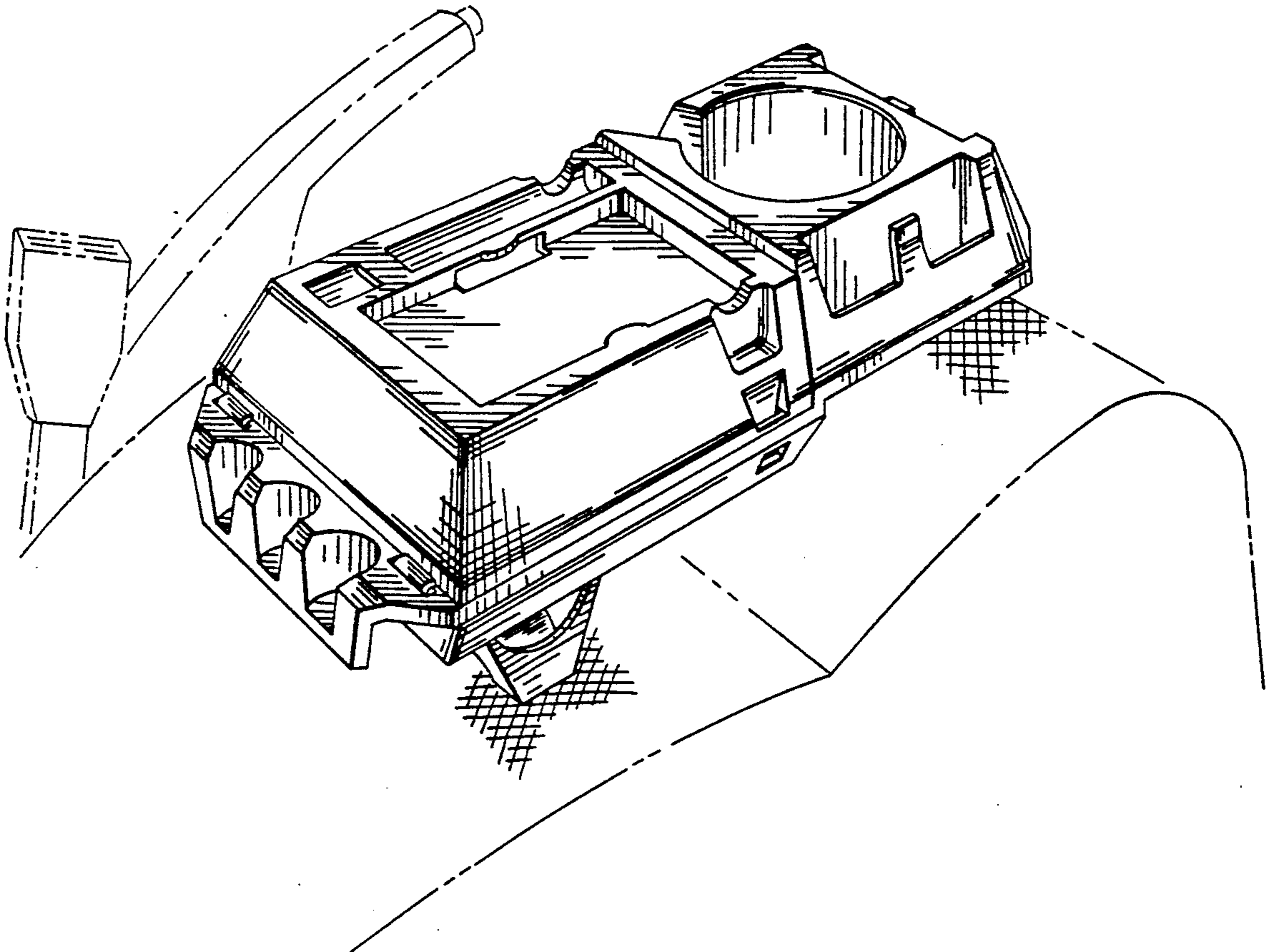

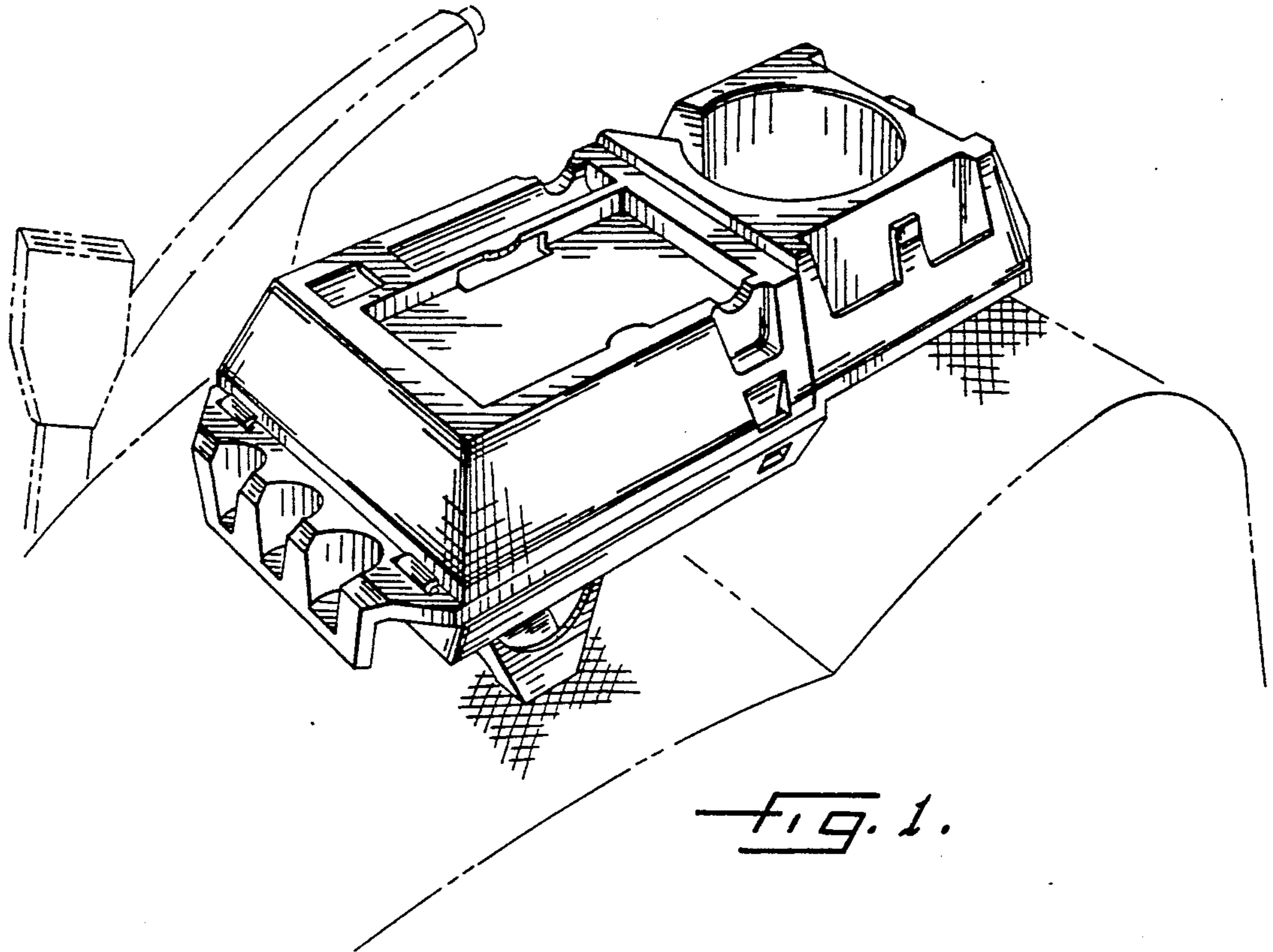

FIG. 1.

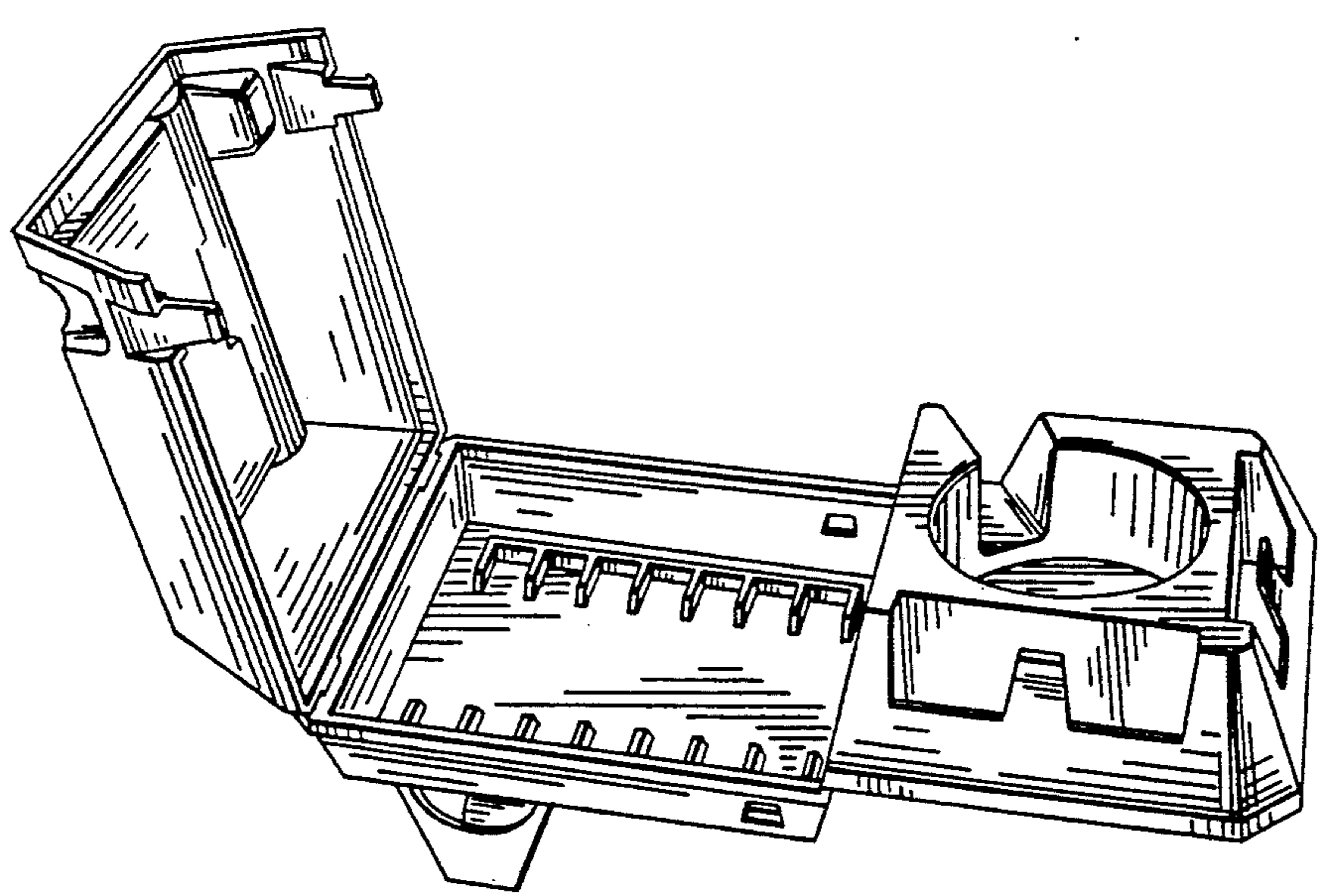

FIG. 2.

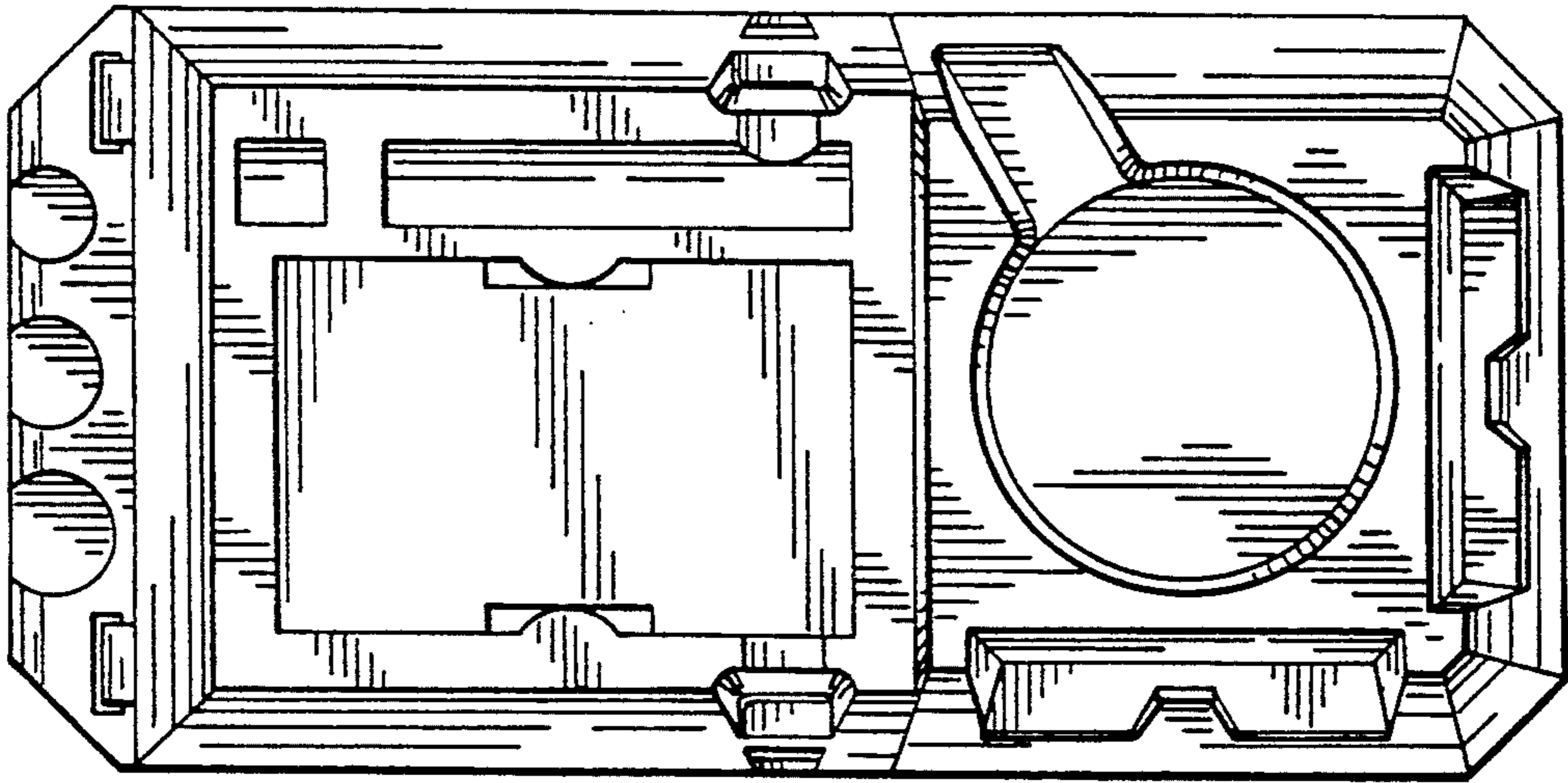

FIG. 3.

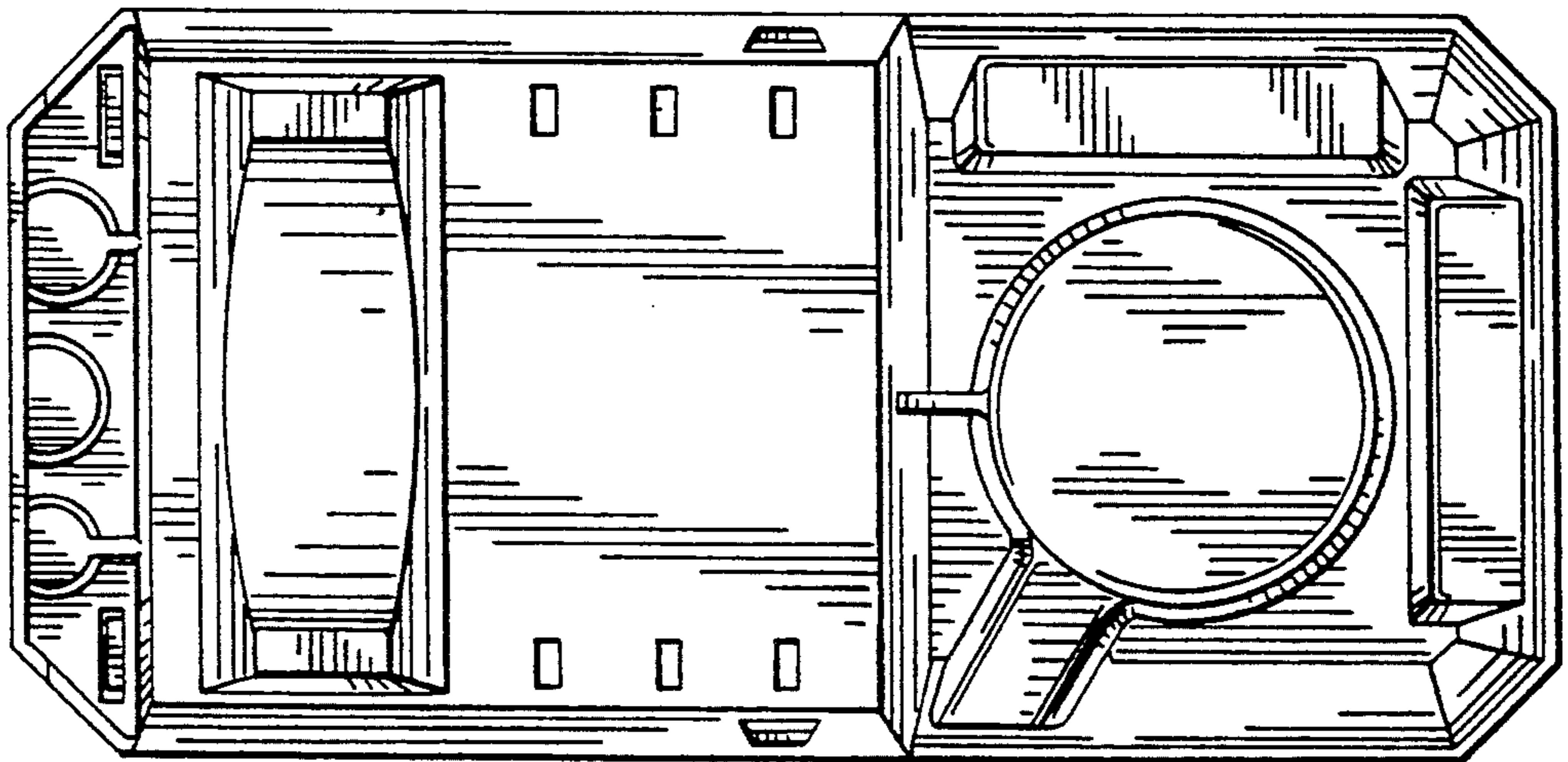

FIG. 4.

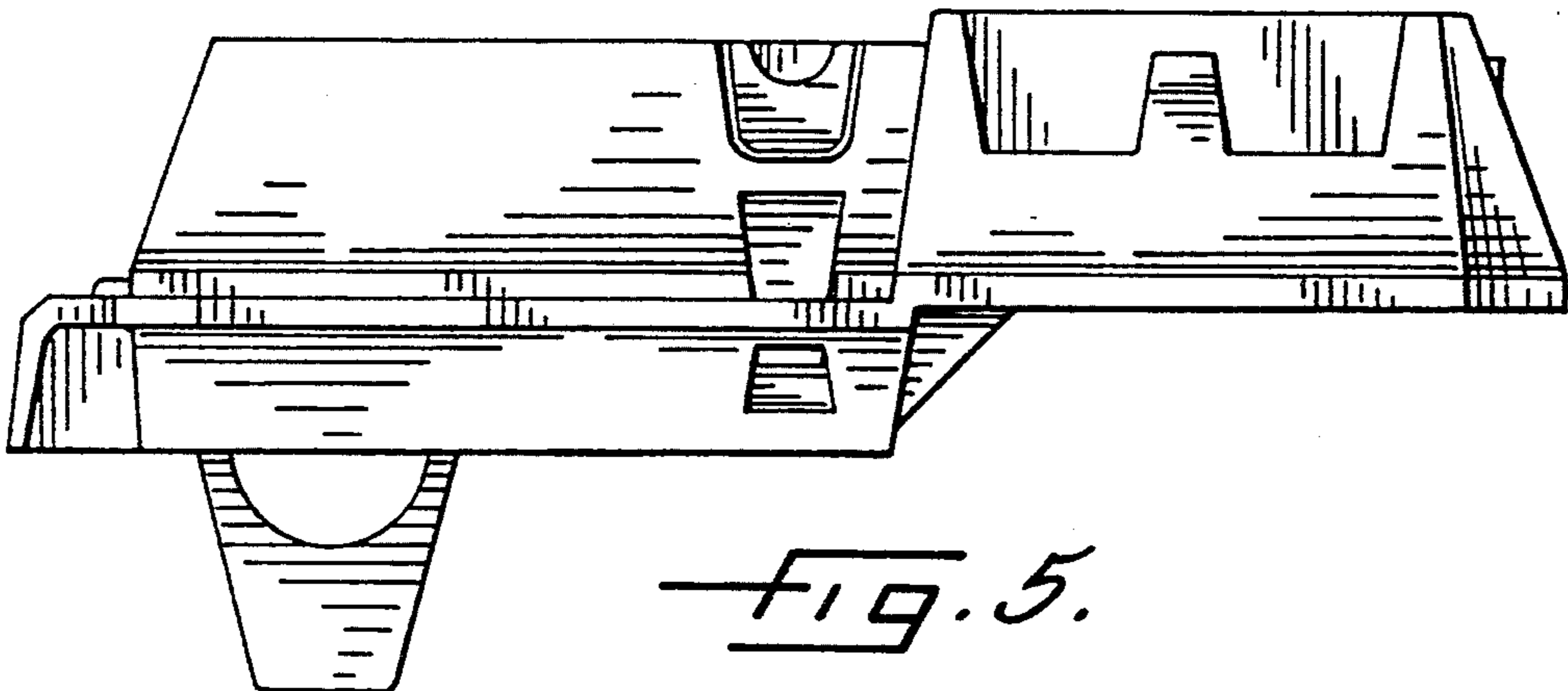

FIG. 5.

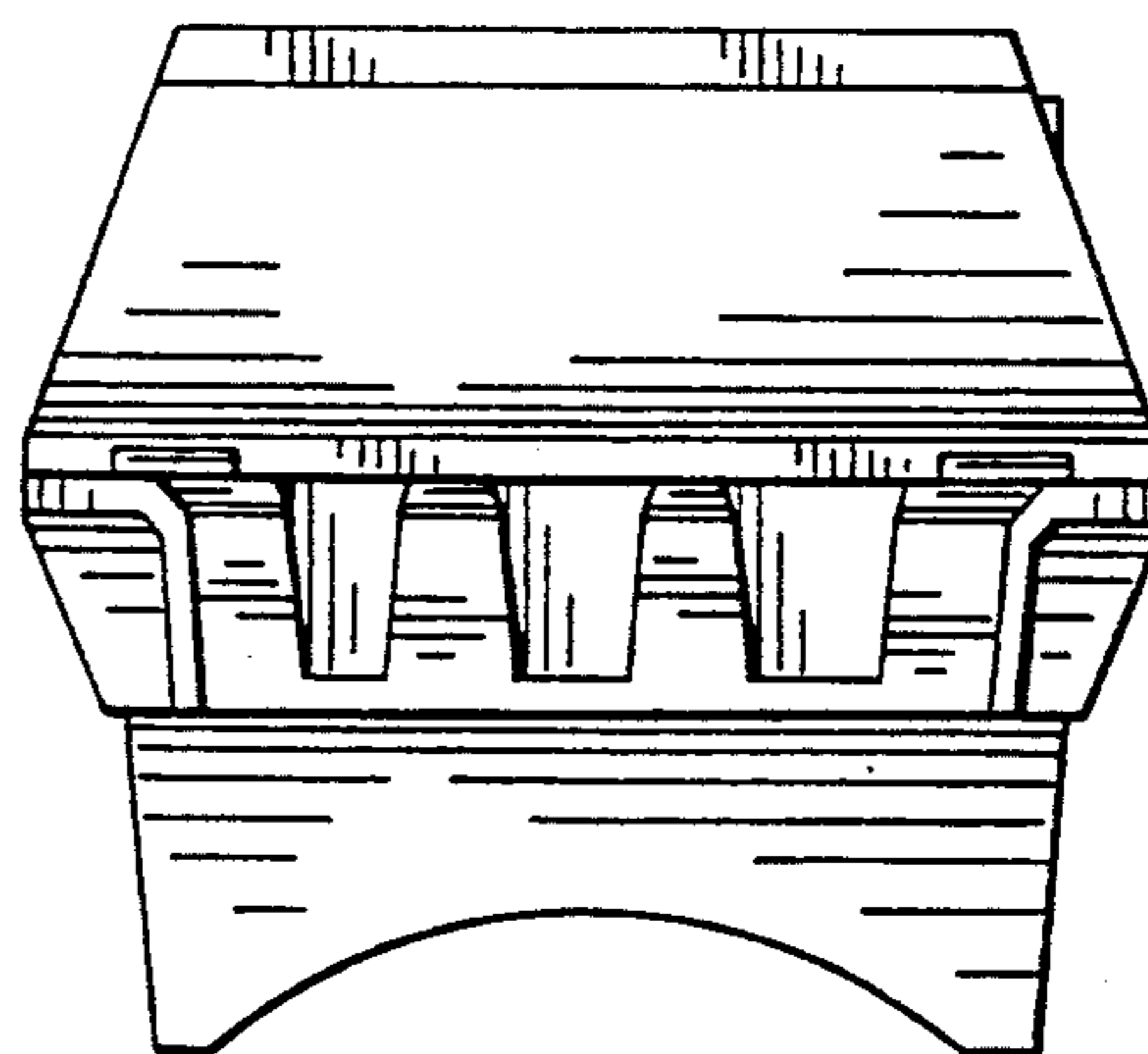
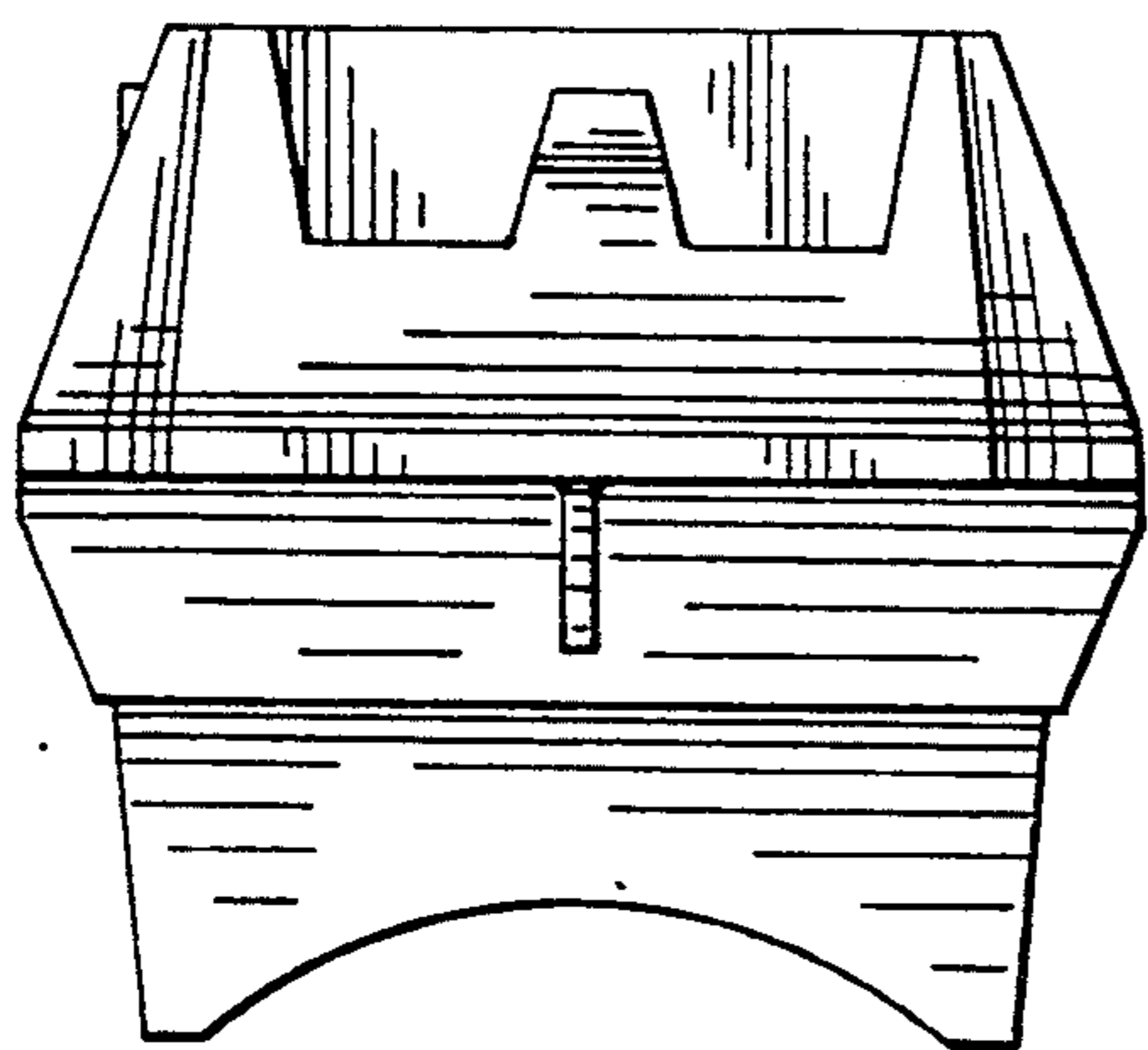
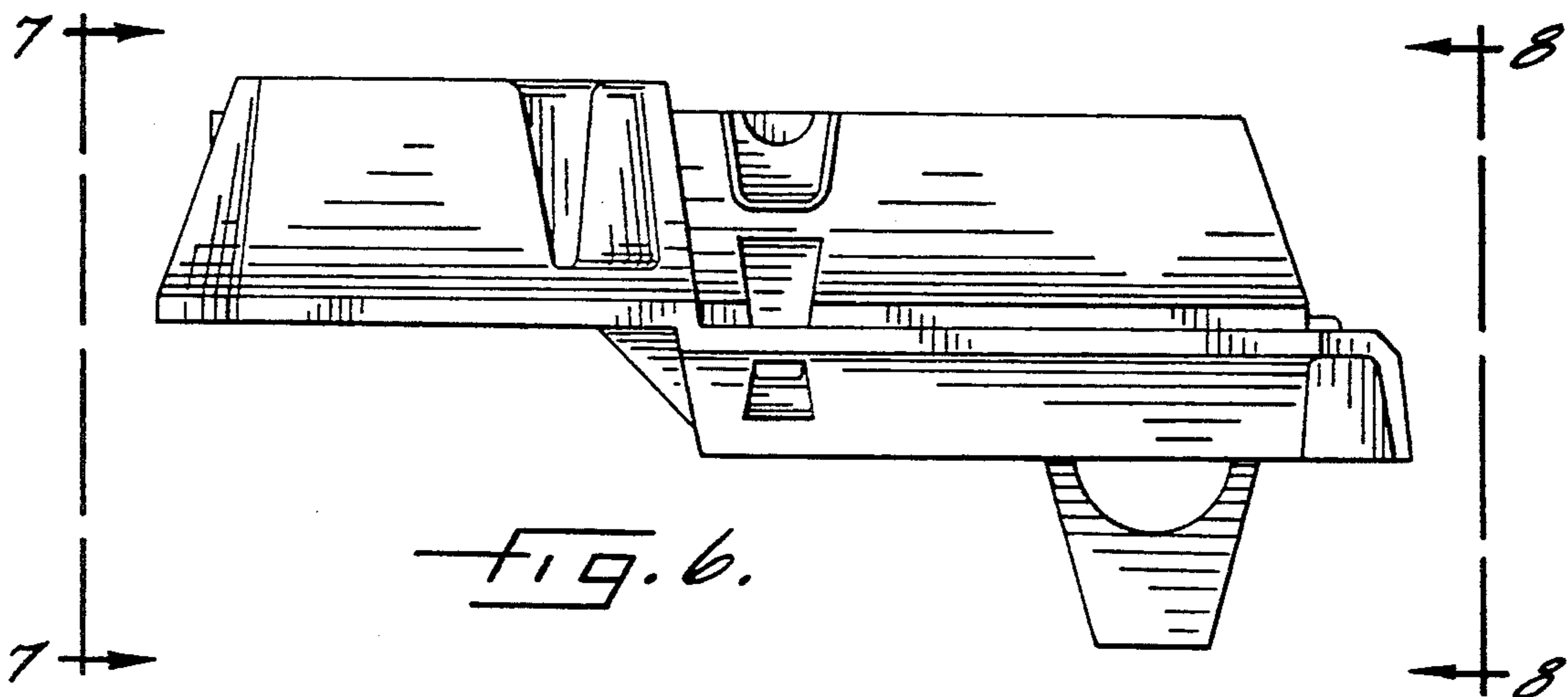

FIG. 7.

FIG. 8.

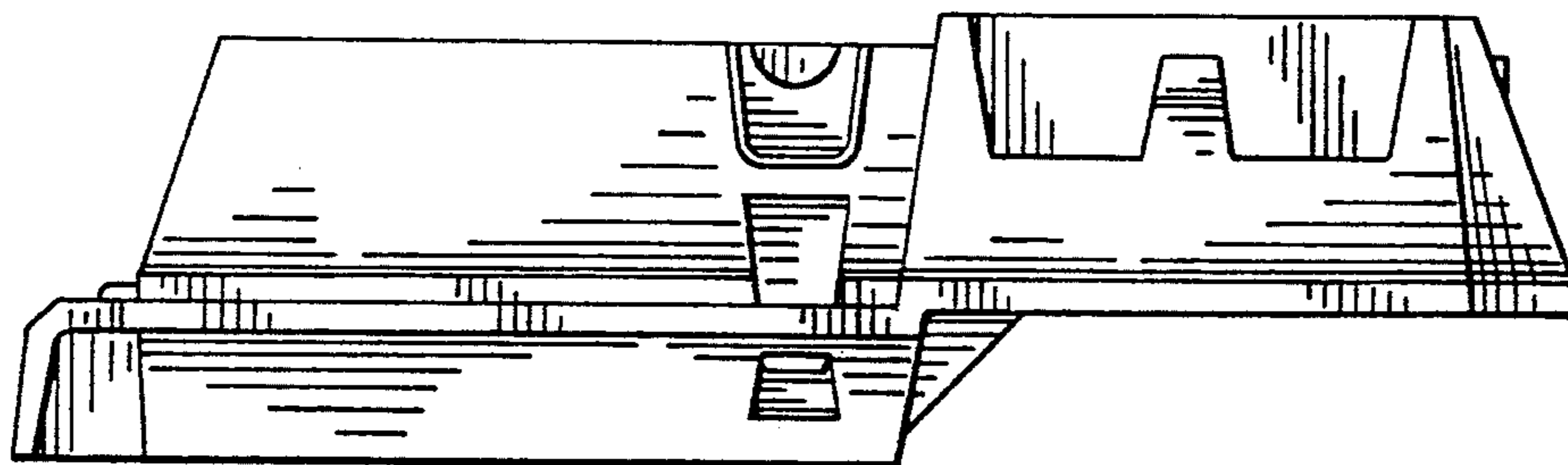

FIG. 9.