



US00D328731S

# United States Patent [19]

[11] Patent Number: Des. 328,731

Smith et al.

[45] Date of Patent: \*\* Aug. 18, 1992

[54] COMBINED VEHICLE CARRIER AND SUPPORT ARM

[56] References Cited

[76] Inventors: Glenn C. Smith; Kenneth E. Snyder, both of P.O. Box 2443, Anderson, S.C. 29622

### U.S. PATENT DOCUMENTS

2,620,082	12/1952	Harmon	224/42.42 R
3,687,344	8/1972	Nixon	224/42.03 A
5,033,662	7/1991	Godin	224/42.03 A

Primary Examiner—James M. Gandy  
Attorney, Agent, or Firm—Bailey & Hardaway

[\*\*] Term: 14 Years

[57] CLAIM

The ornamental design for a combined vehicle carrier and support arm, as shown.

[21] Appl. No.: 482,674

### DESCRIPTION

[22] Filed: Feb. 20, 1990

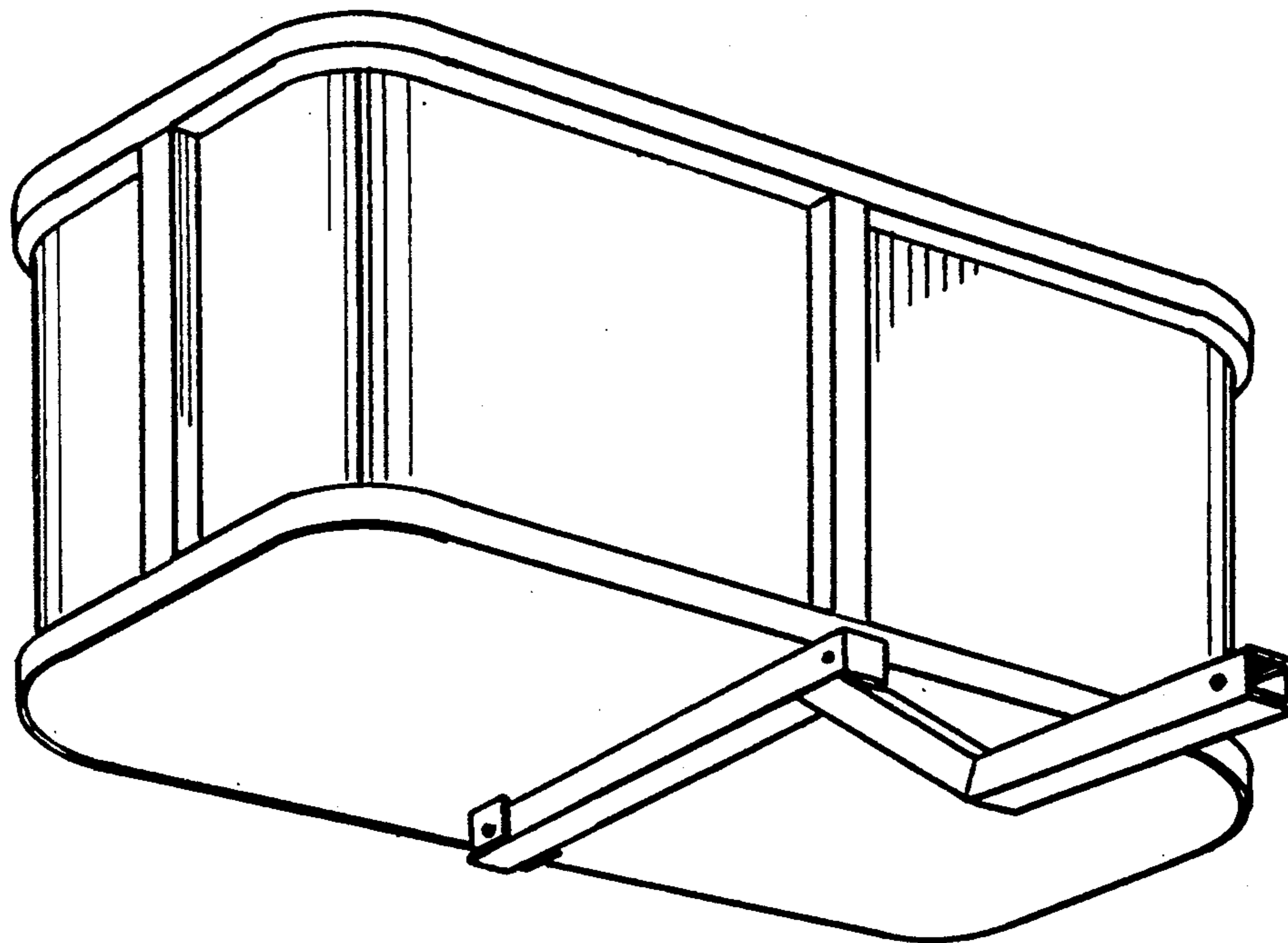
FIG. 1 is a top, front, and left side perspective view of a combined vehicle carrier and support arm showing our new design;

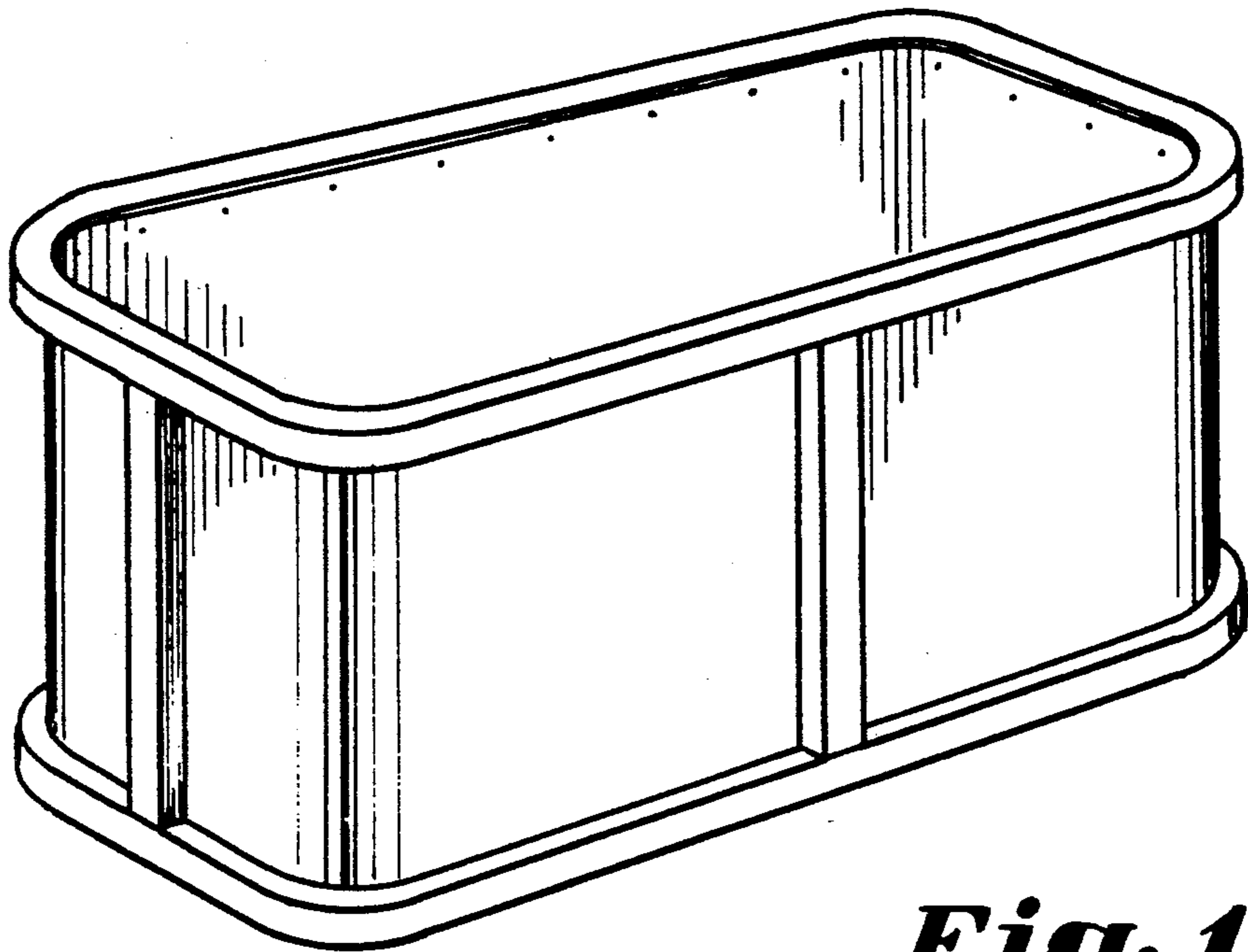
[52] U.S. Cl. .... D12/157

FIG. 2 is a bottom, rear and right side perspective view thereof;

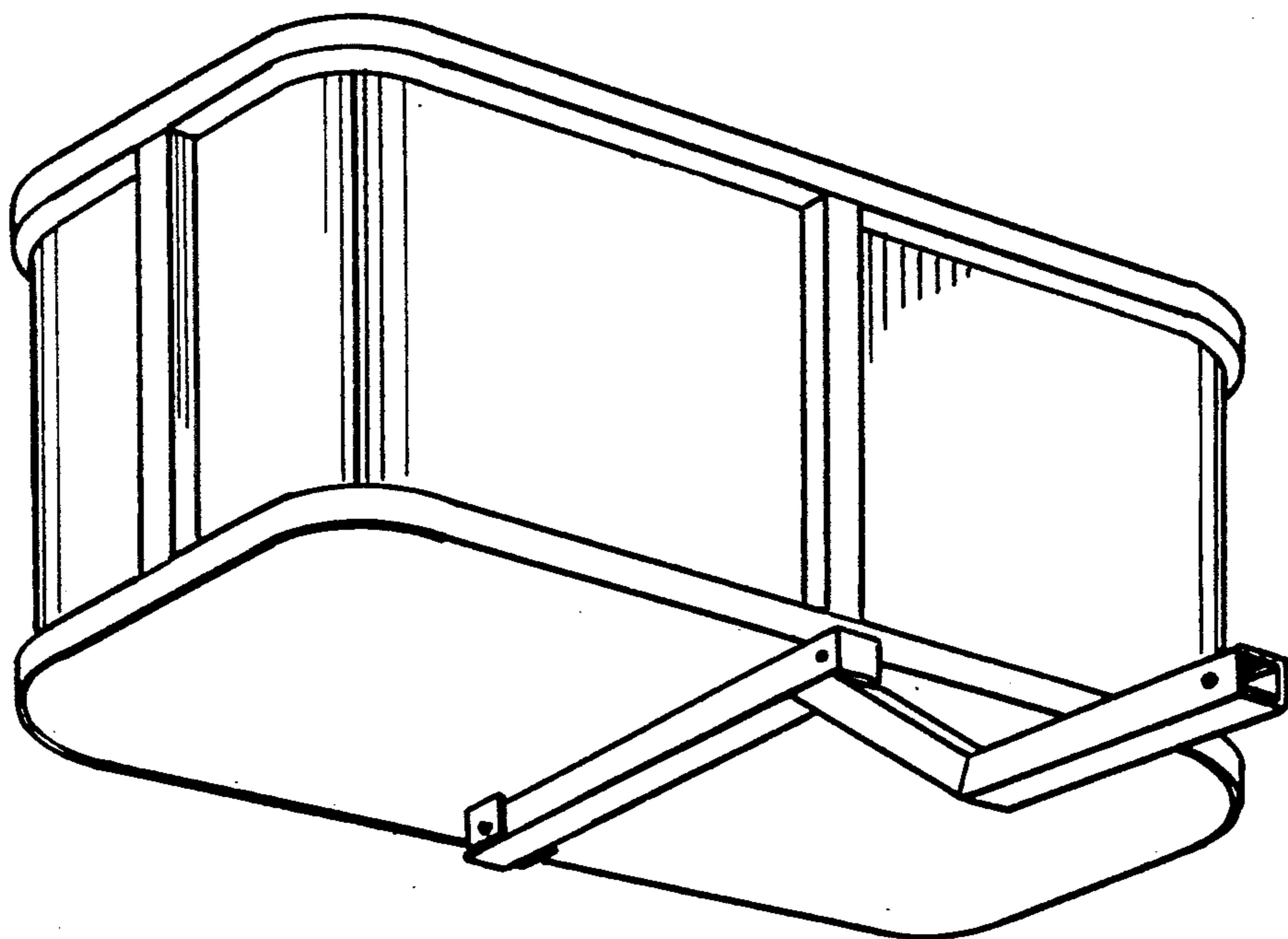
[58] Field of Search ..... D12/157; D34/40; D3/30.1, 40; D9/430, 432; 224/273, 420.03 R, 42.03 A, 42.42 R

FIG. 3 is a top plan view thereof; and, FIG. 4 is a bottom plan view thereof.

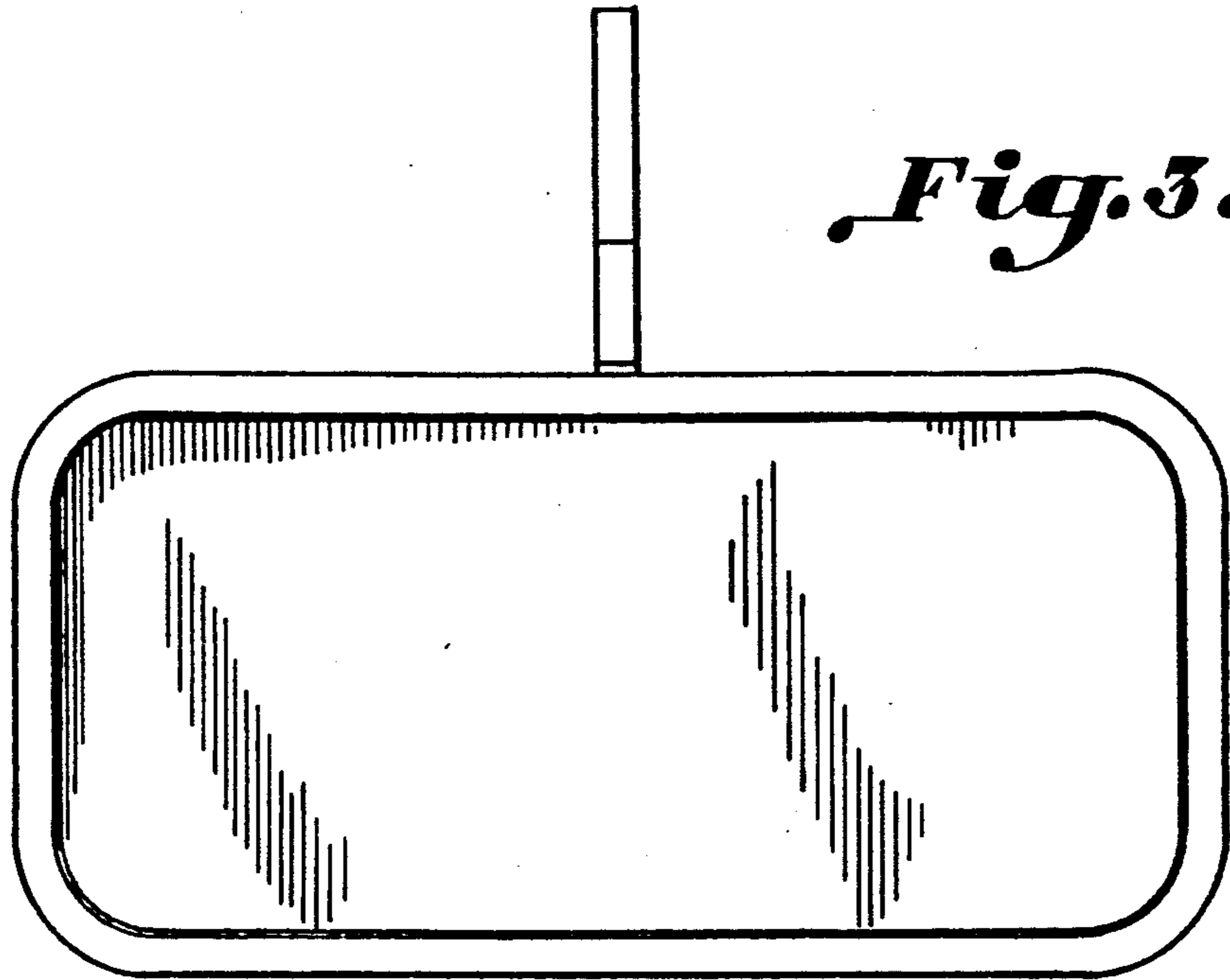




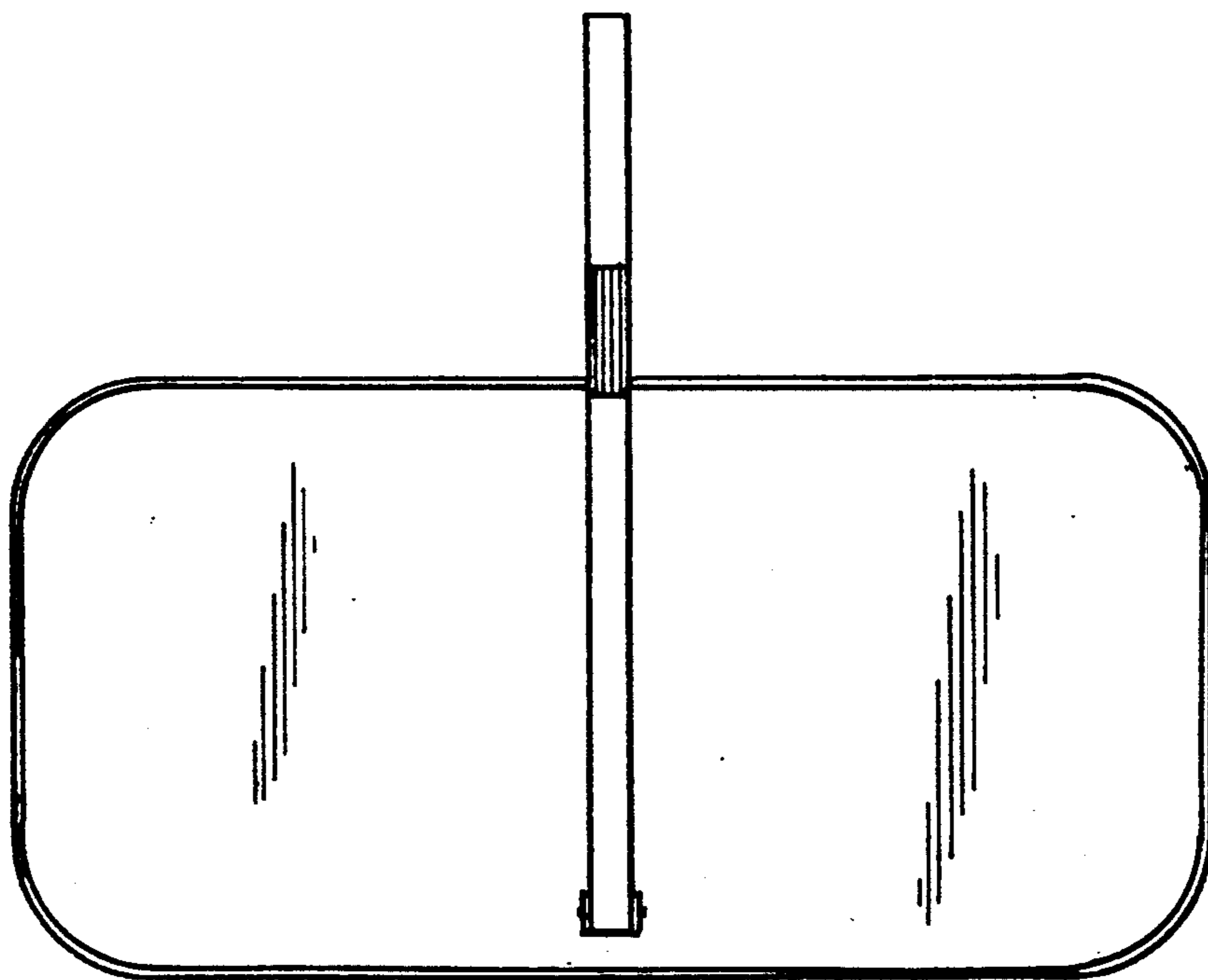
*Fig. 1.*



*Fig. 2.*



*Fig. 3.*



*Fig. 4.*