



US00D328672S

United States Patent [19]

[11] Patent Number: Des. 328,672

van de Meene

[45] Date of Patent: ** Aug. 18, 1992

[54] COMBINED SUITCASE, ATTACHE-CASE AND BAG

[57] CLAIM

The ornamental design for a combined suitcase, attache-case and bag, as shown and described.

[75] Inventor: Hendrik P. C. van de Meene, Kerns, Switzerland

DESCRIPTION

[73] Assignee: Homar N.V., Netherlands

FIG. 1 is a front perspective view of a combined suitcase, attache-case, and bag showing my new design; FIG. 2 is a rear perspective view in a detached position thereof;

[**] Term: 14 Years

FIG. 3 is a rear perspective view thereof;

[21] Appl. No.: 557,032

FIG. 4 is a rear perspective view with the flap in an open position thereof;

[22] Filed: Jul. 24, 1990

FIG. 5 is a rear perspective view with the flap in an open position;

[52] U.S. Cl. D3/76

FIG. 6 is a rear perspective view with the handle and wheels in an extended position;

[58] Field of Search D3/72, 76, 79, 74, 78; 190/111, 18 R, 110, 18 A, 112, 113, 120, 115, 100, 102, 109, 107, 900, 901, 902, 903; 312/244; 224/205, 151; 206/286, 287

FIG. 7 is a front elevational view in an unfolded position;

[56] References Cited

FIG. 8 is a top plan view;

U.S. PATENT DOCUMENTS

FIG. 9 is a rear elevational view;

- D. 292,745 11/1987 Allen D3/76 X
- D. 303,177 9/1989 Leaman D3/76
- D. 322,359 12/1991 Diefenbach D3/72 X
- 2,479,824 8/1949 Fass 190/903 X
- 3,963,102 6/1976 Carp 190/111 X
- 4,738,340 4/1988 Crespi 190/18 A X
- 4,995,487 2/1991 Plath 190/18 A
- 4,998,603 3/1991 Nordstrom 190/110 X

FIG. 10 is a front elevational view;

FIG. 11 is a bottom plan view;

FIG. 12 is a side elevational view, the opposite side is a mirror image;

FOREIGN PATENT DOCUMENTS

1961300 8/1989 Benelux .

FIG. 13 is a top plan view of the suitcase;

FIG. 14 is a front elevational view thereof;

FIG. 15 is a bottom plan view thereof;

FIG. 16 is a front elevational view thereof;

FIG. 17 is a side elevational view thereof;

FIG. 18 is a top plan view of the attache case;

FIG. 19 is a front elevational view;

FIG. 20 is a rear elevational view;

FIG. 21 is a side elevational view the opposite side is a mirror image thereof; and,

FIG. 22 is a bottom plan view.

Primary Examiner—A. Hugo Word
Assistant Examiner—Paula A. Mortimer
Attorney, Agent, or Firm—Diller, Ramik & Wight

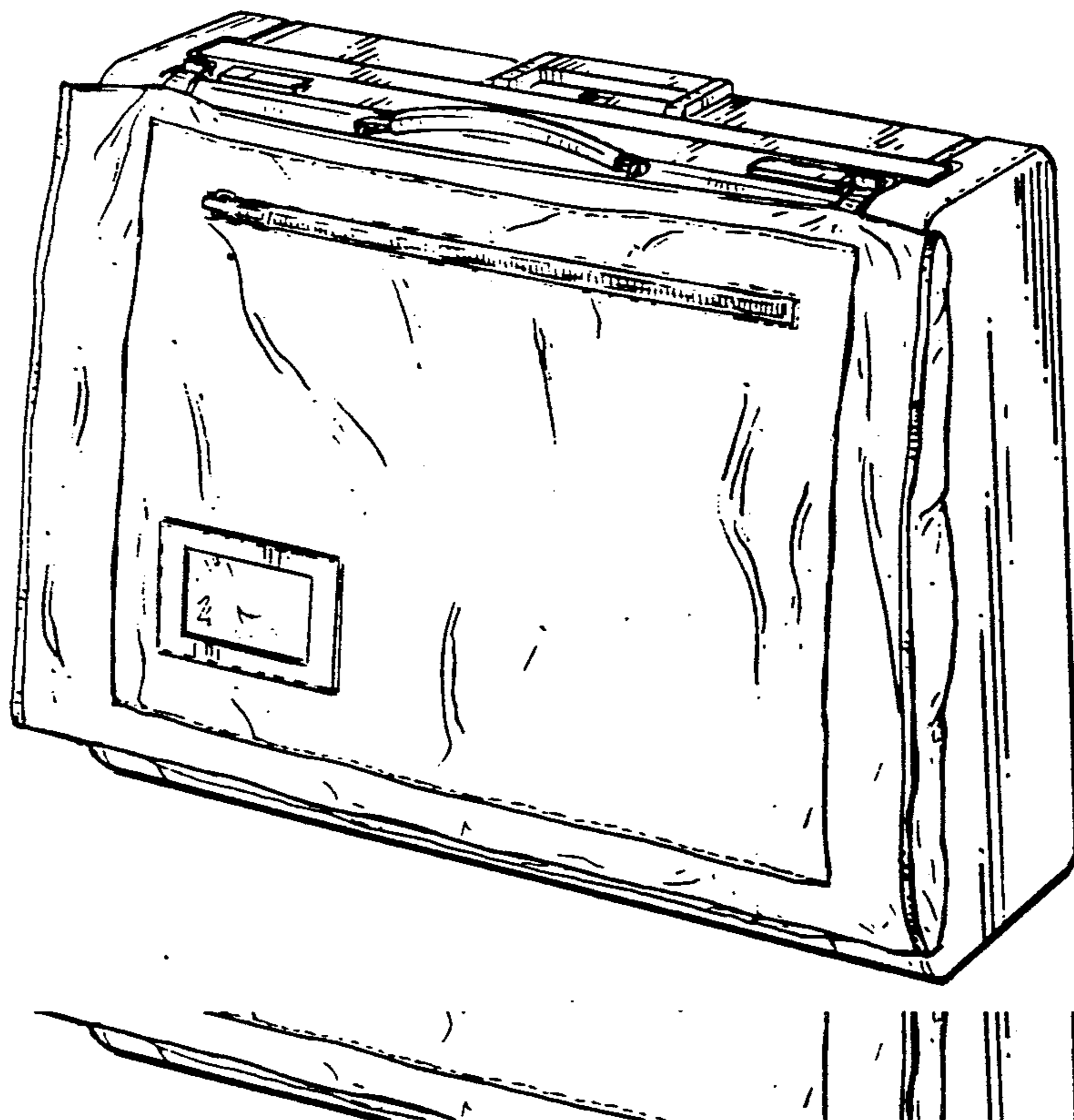

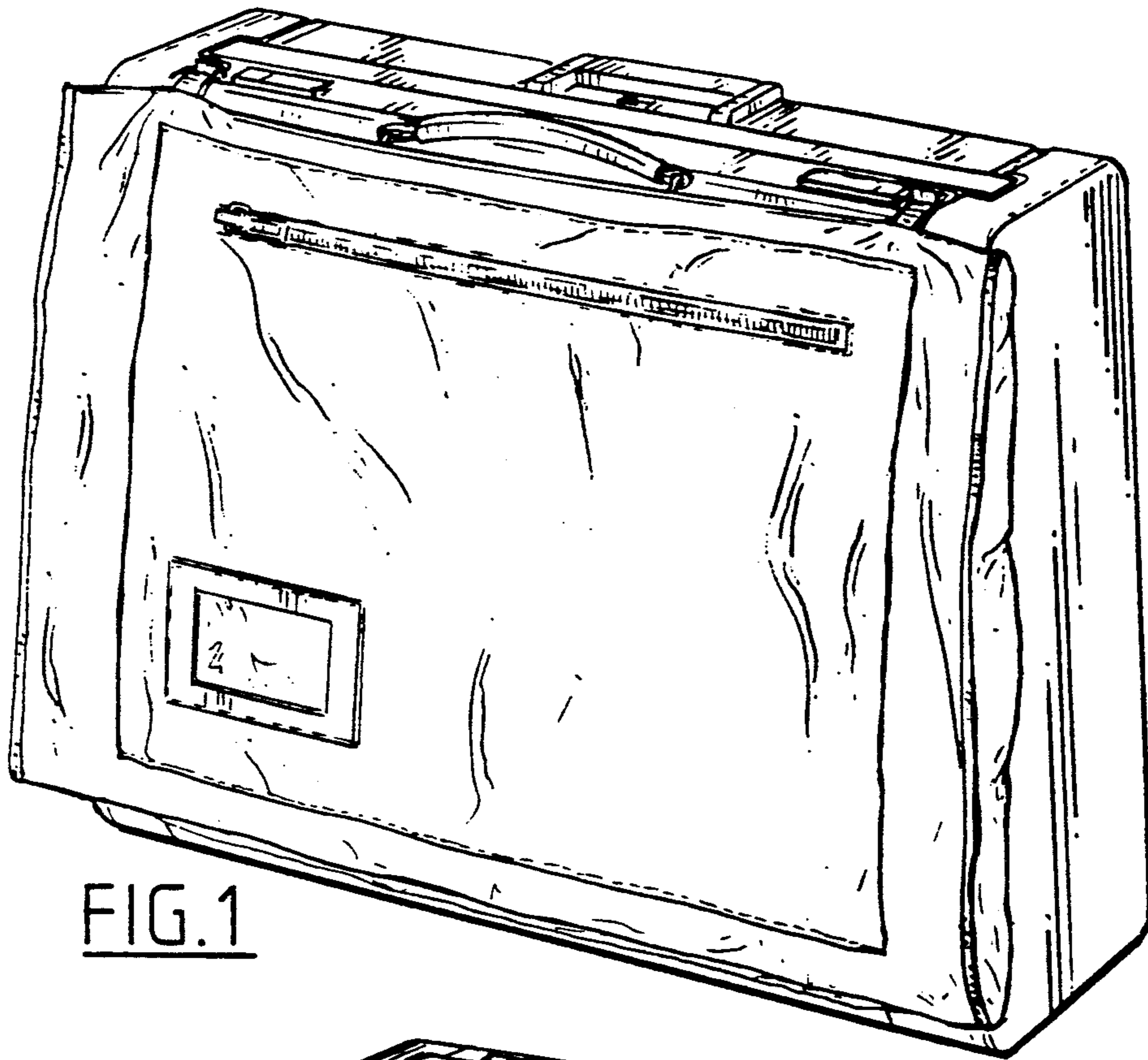

FIG. 1

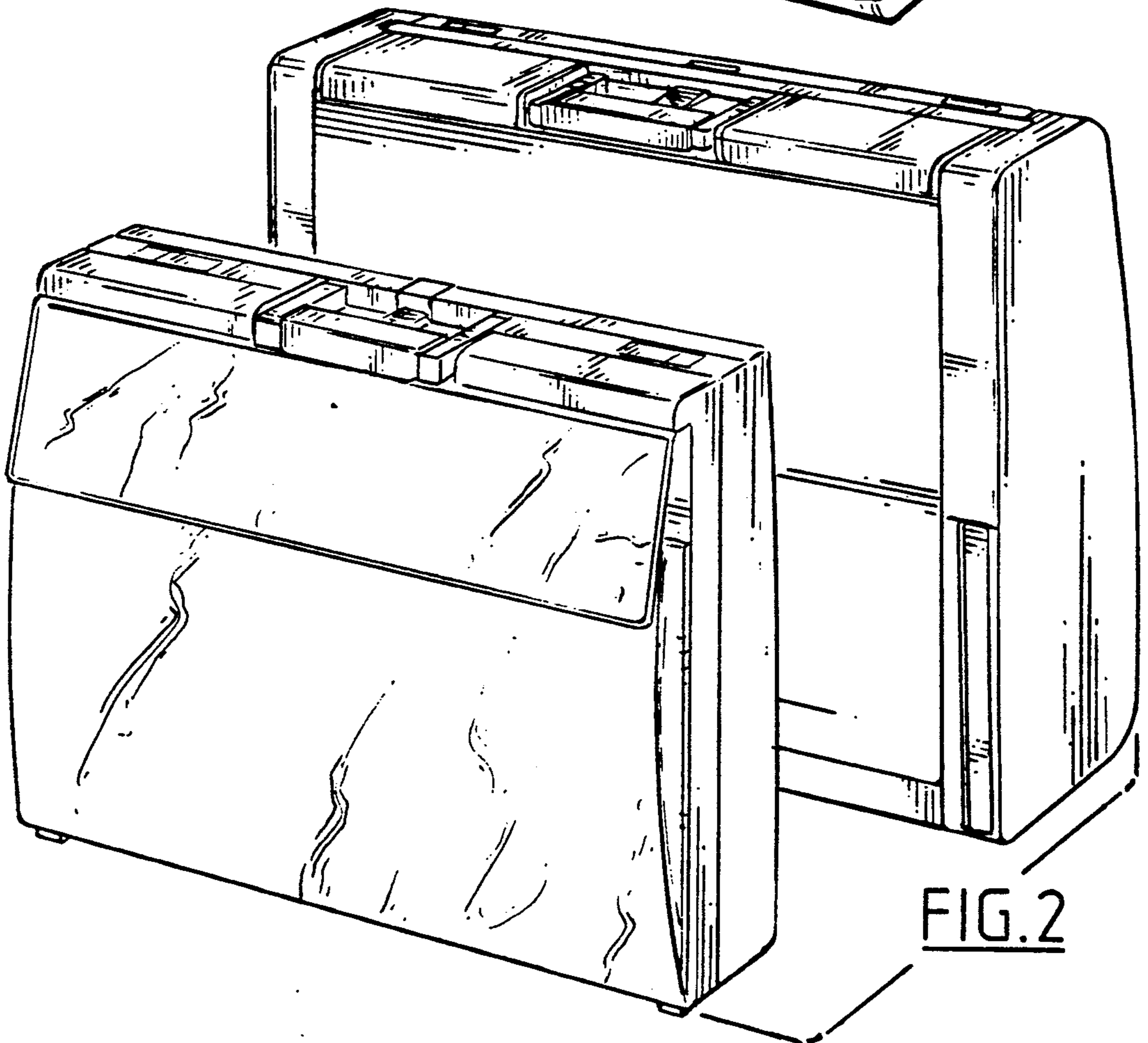

FIG. 2

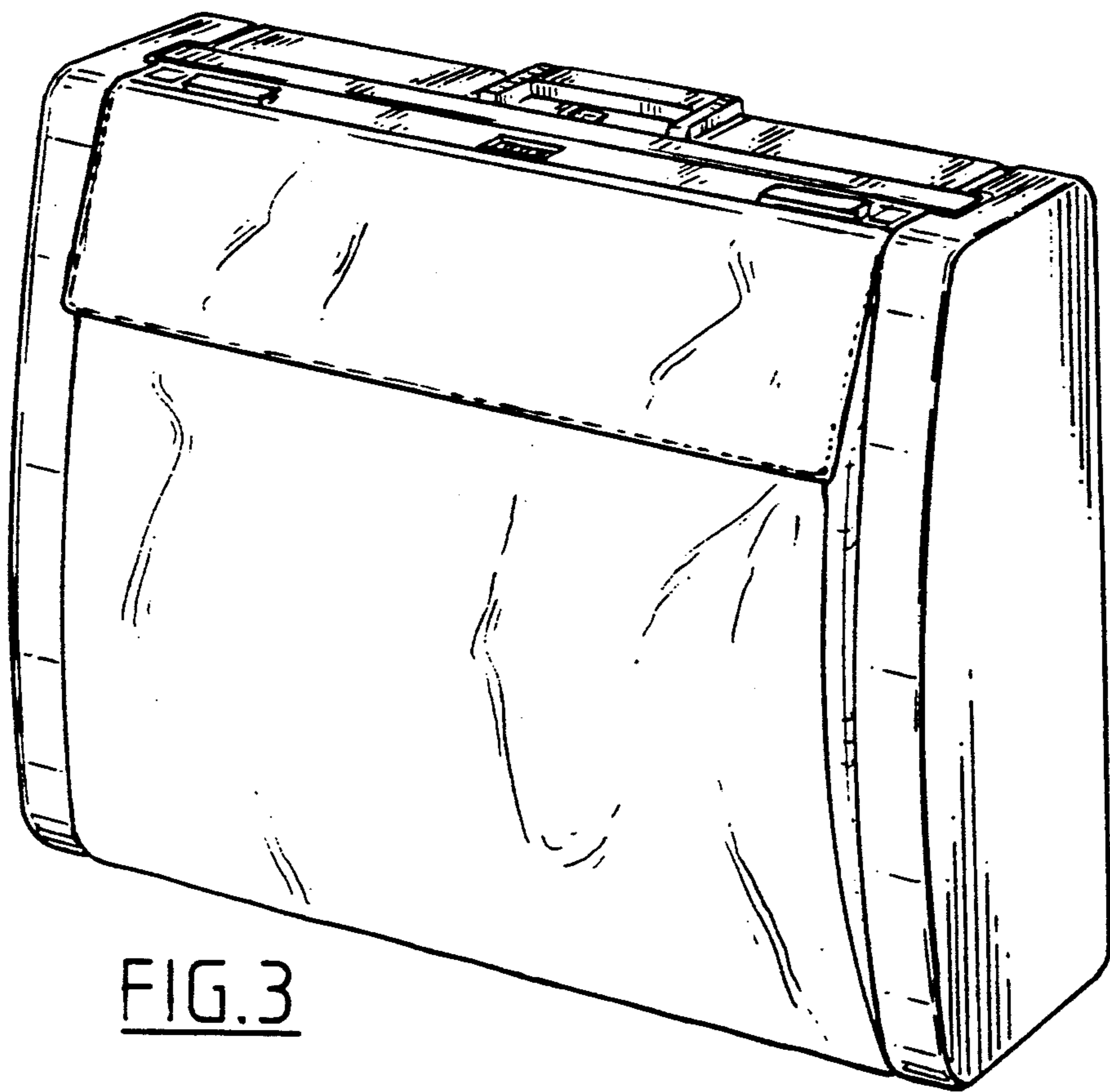

FIG. 3

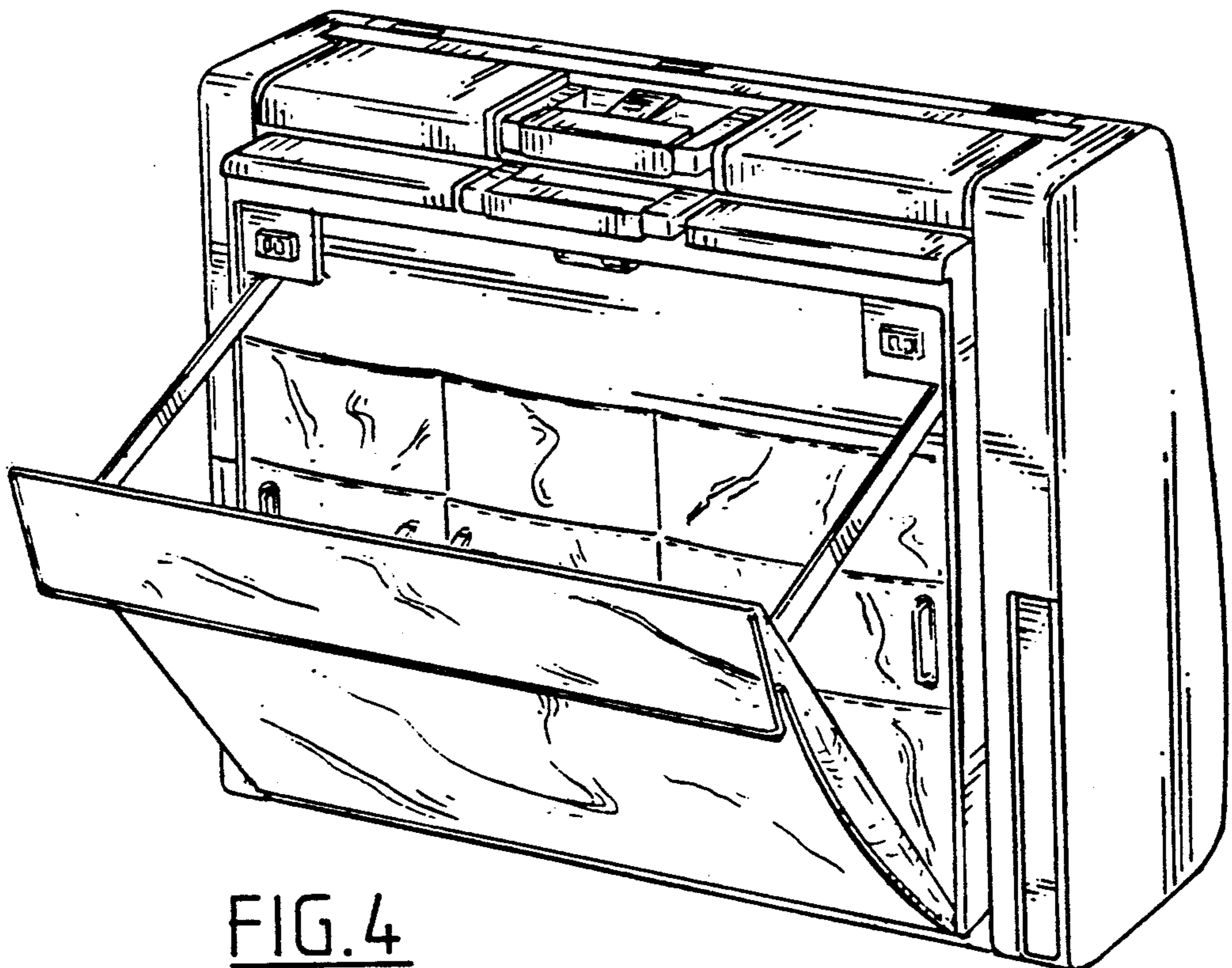

FIG. 4

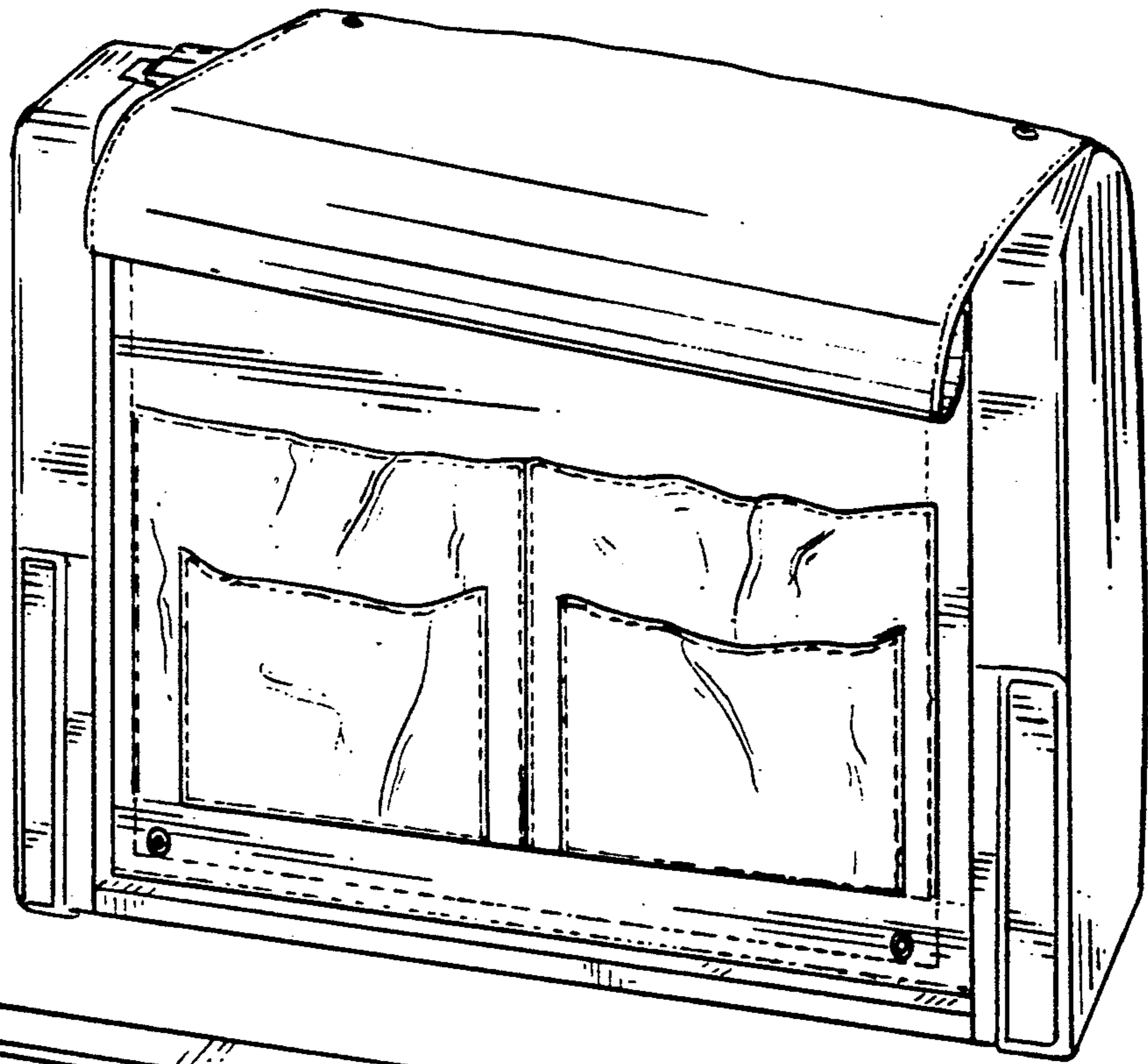

FIG. 5

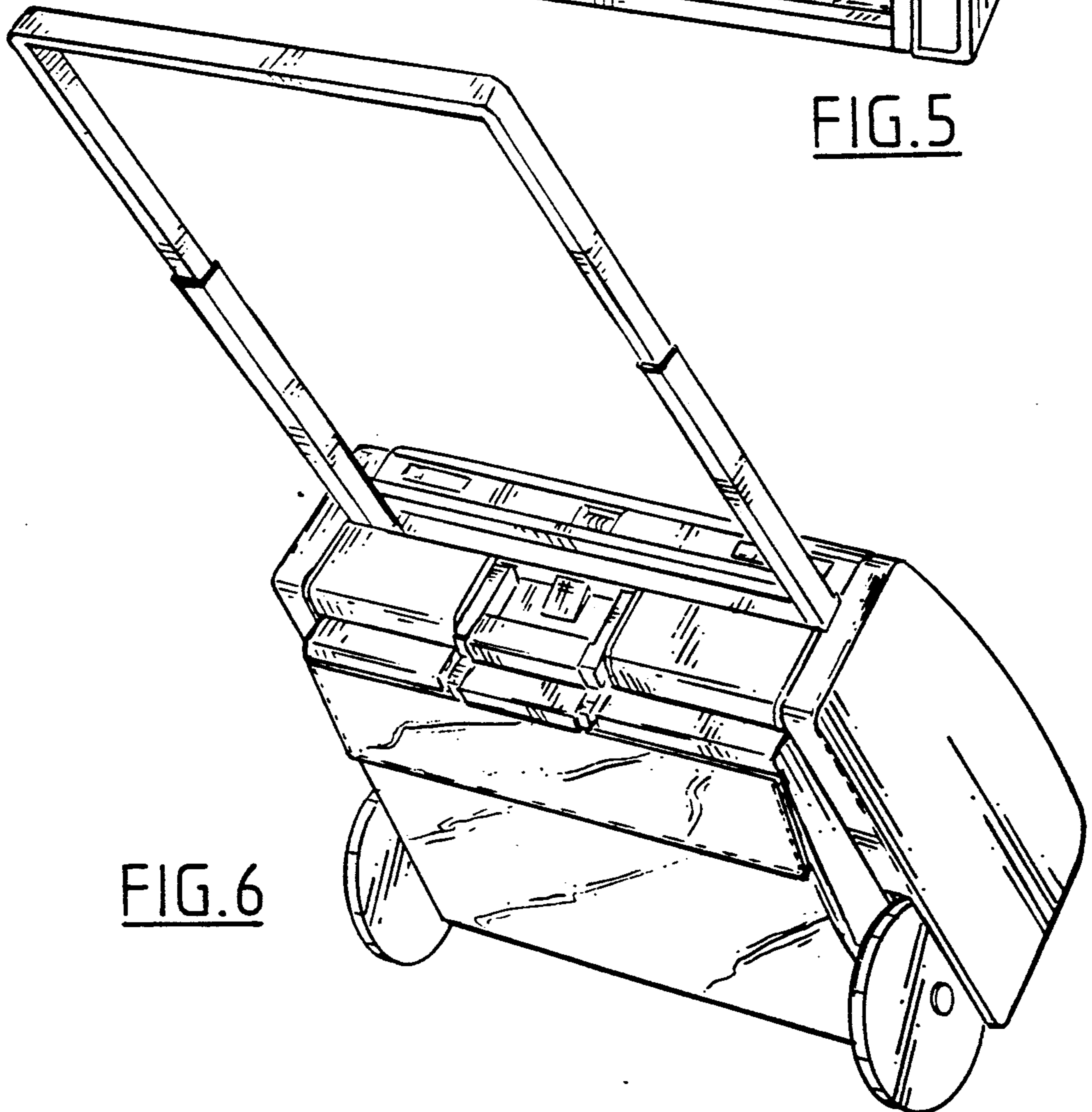

FIG. 6

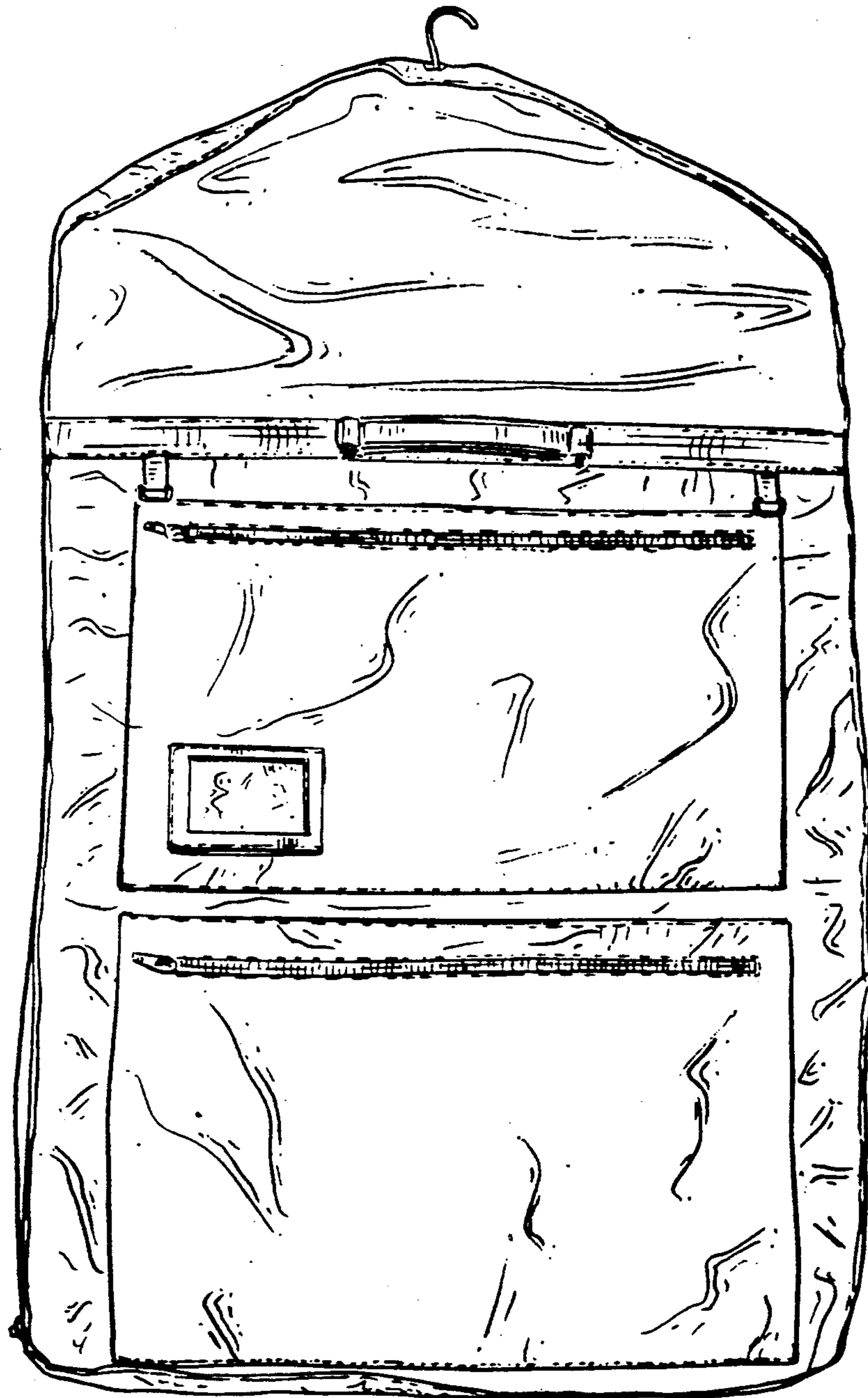

FIG. 7

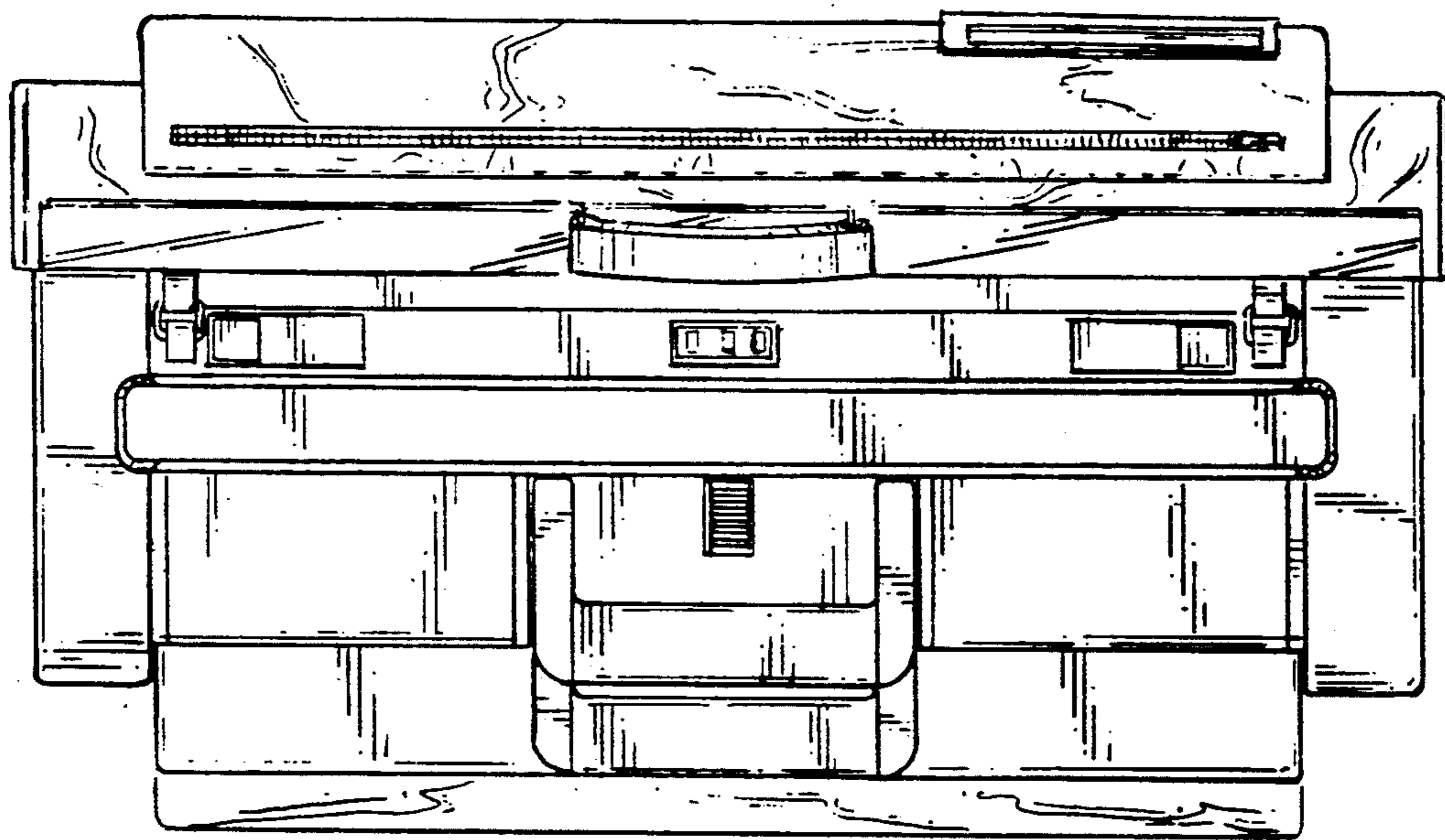

FIG. 8

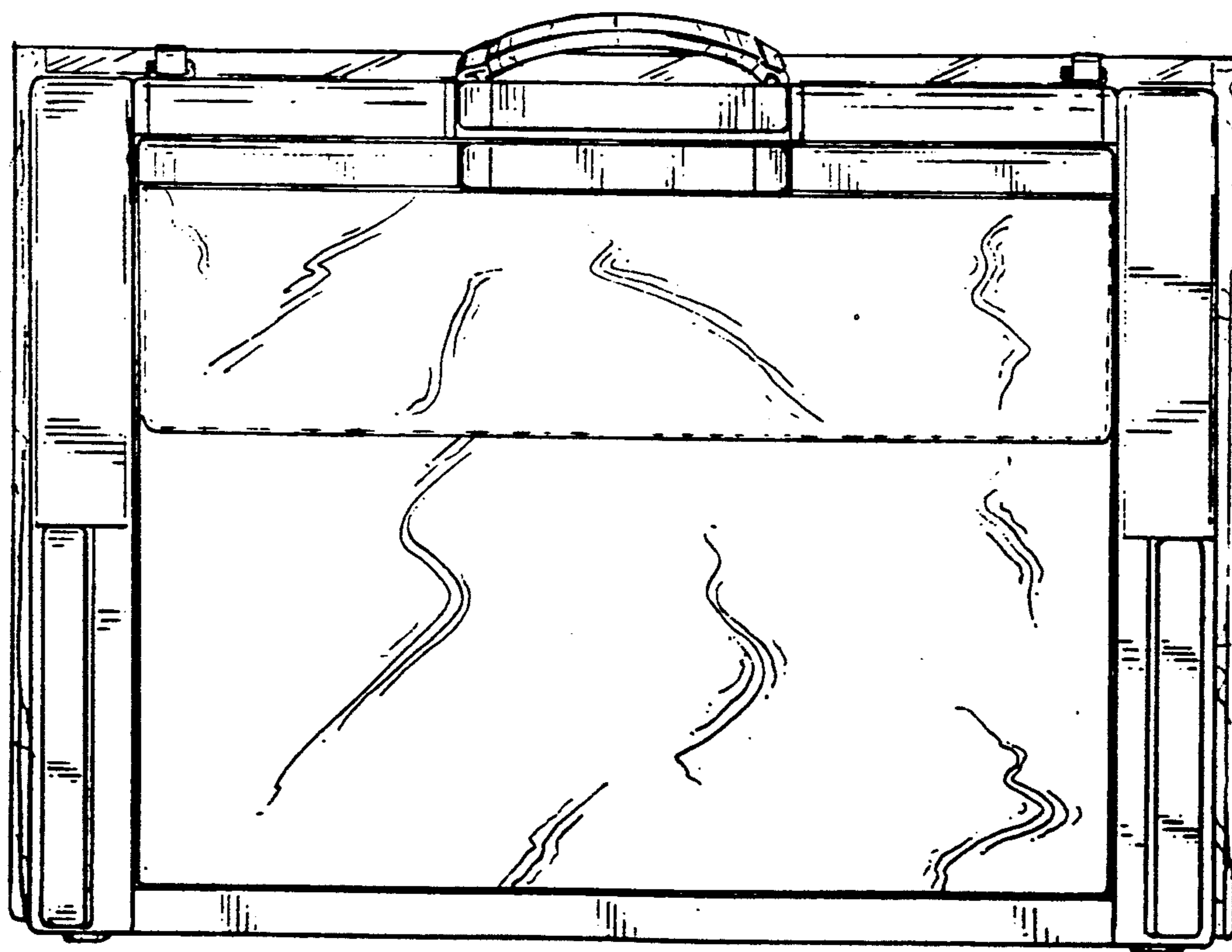

FIG. 9

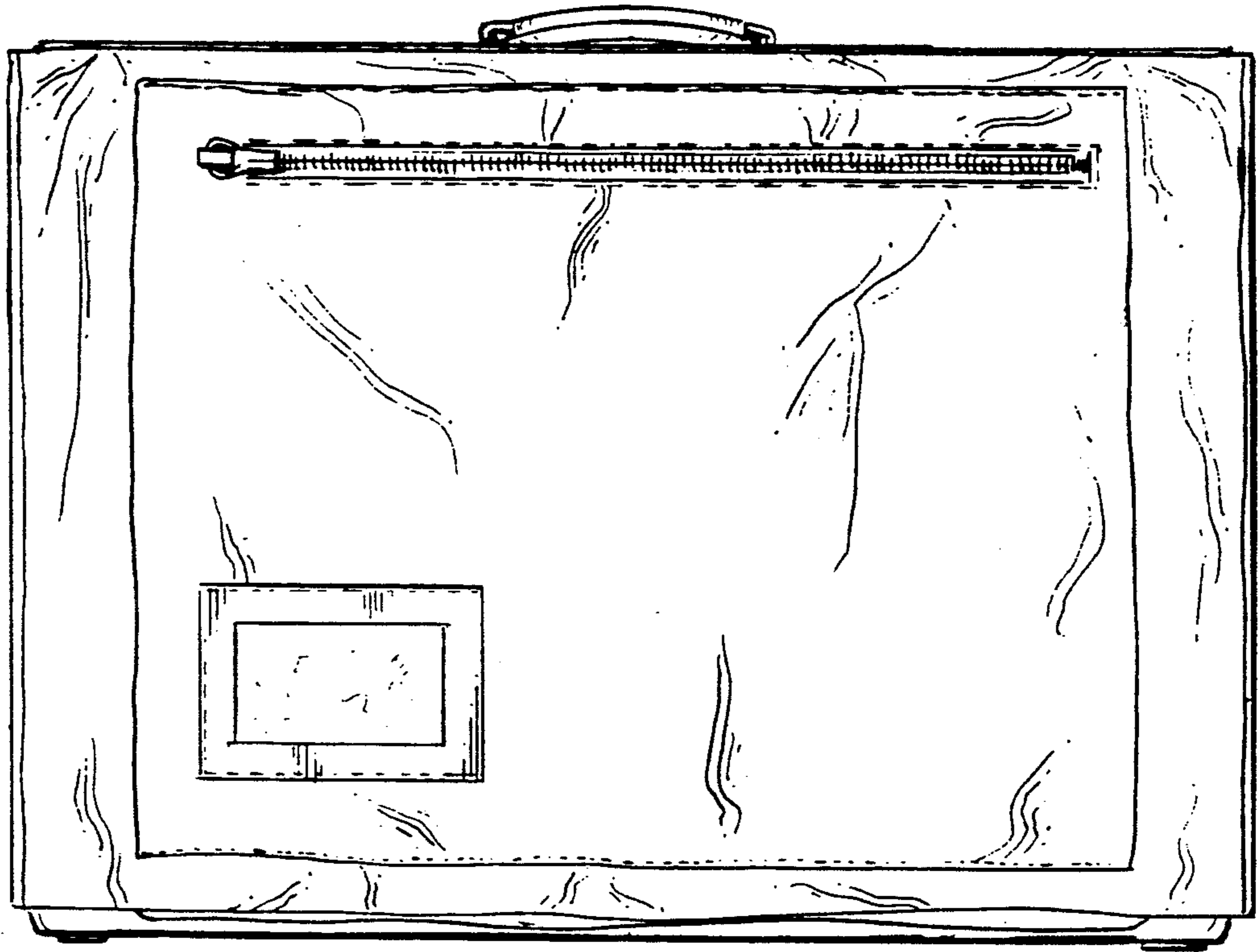

FIG. 10

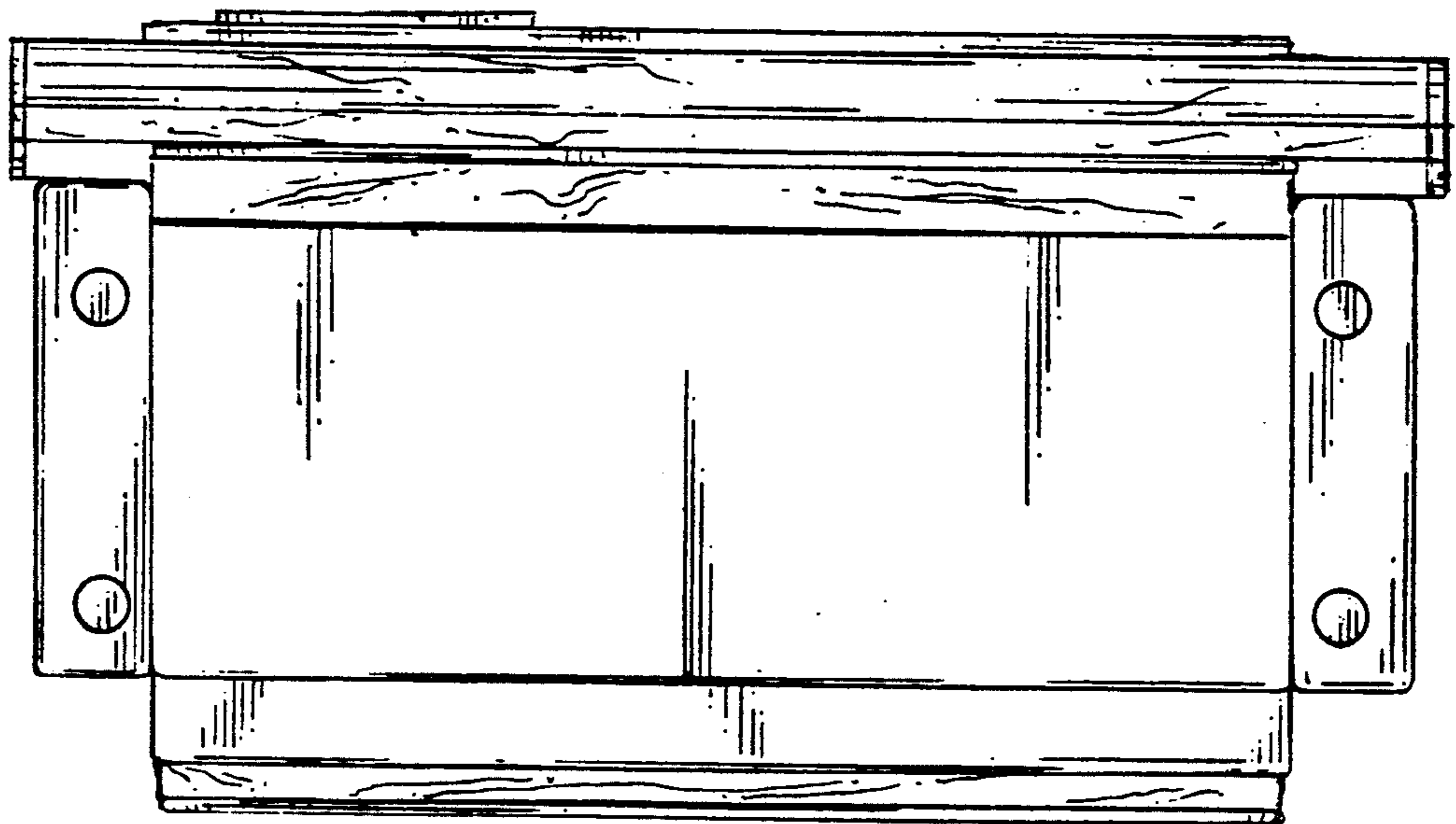

FIG. 11

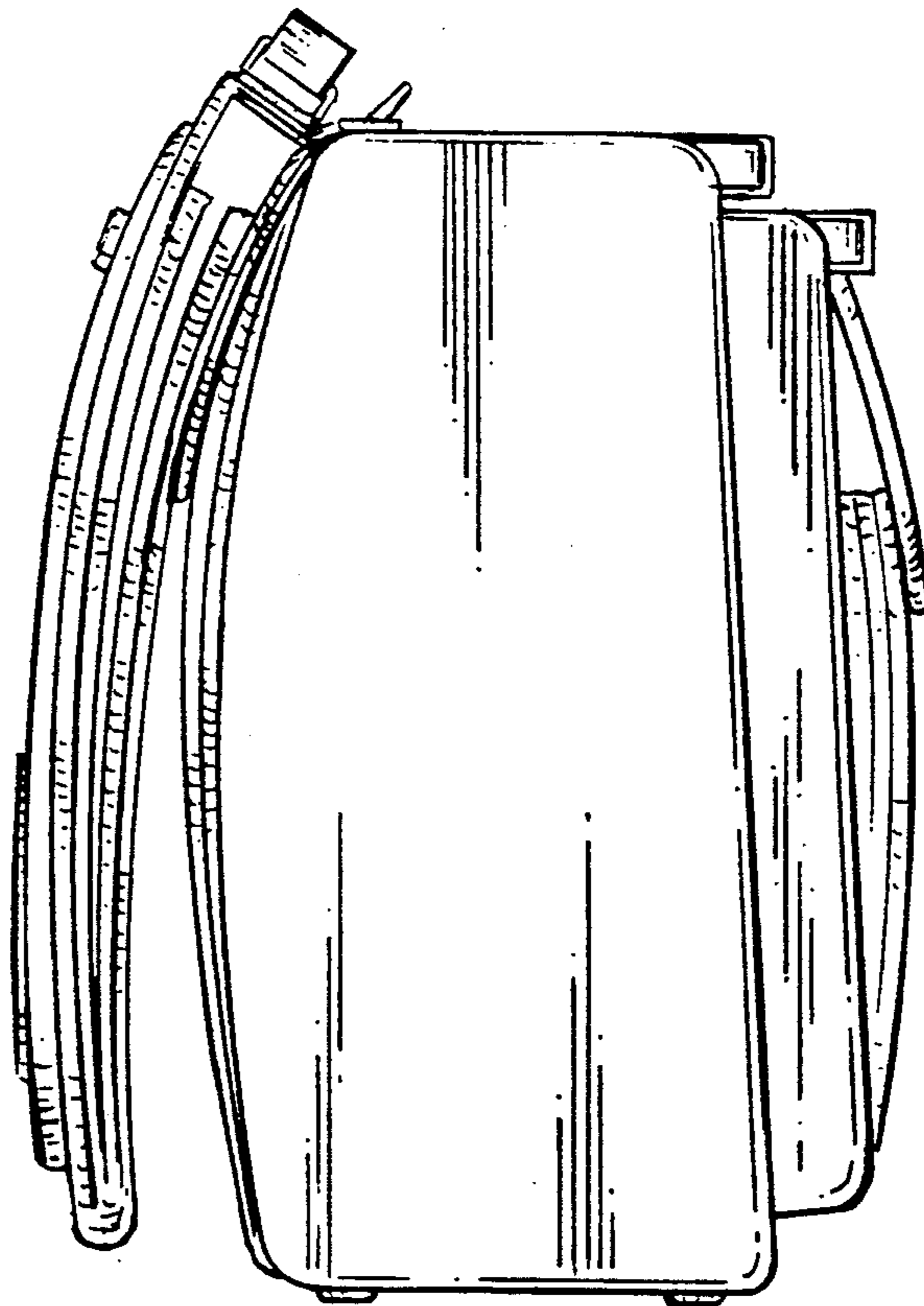

FIG. 12

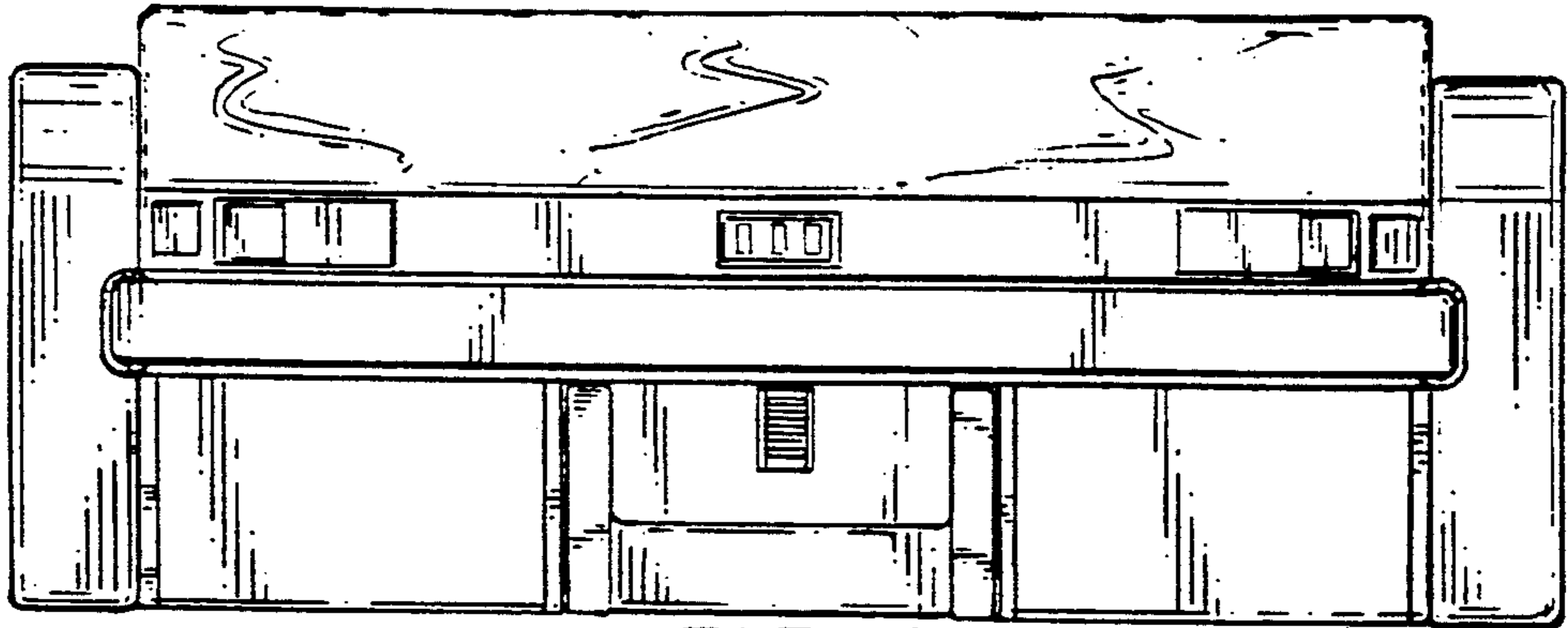

FIG. 13

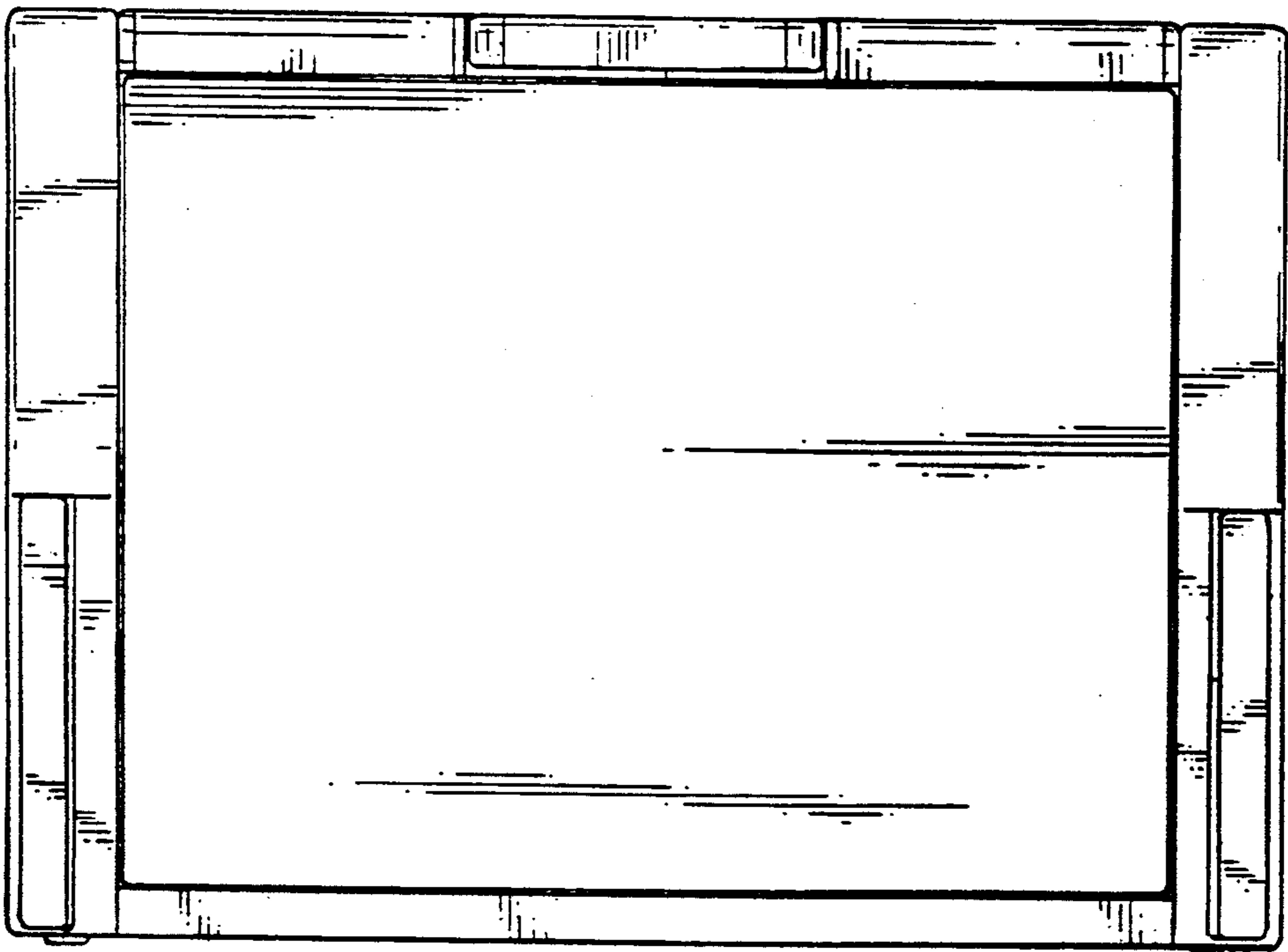

FIG. 14

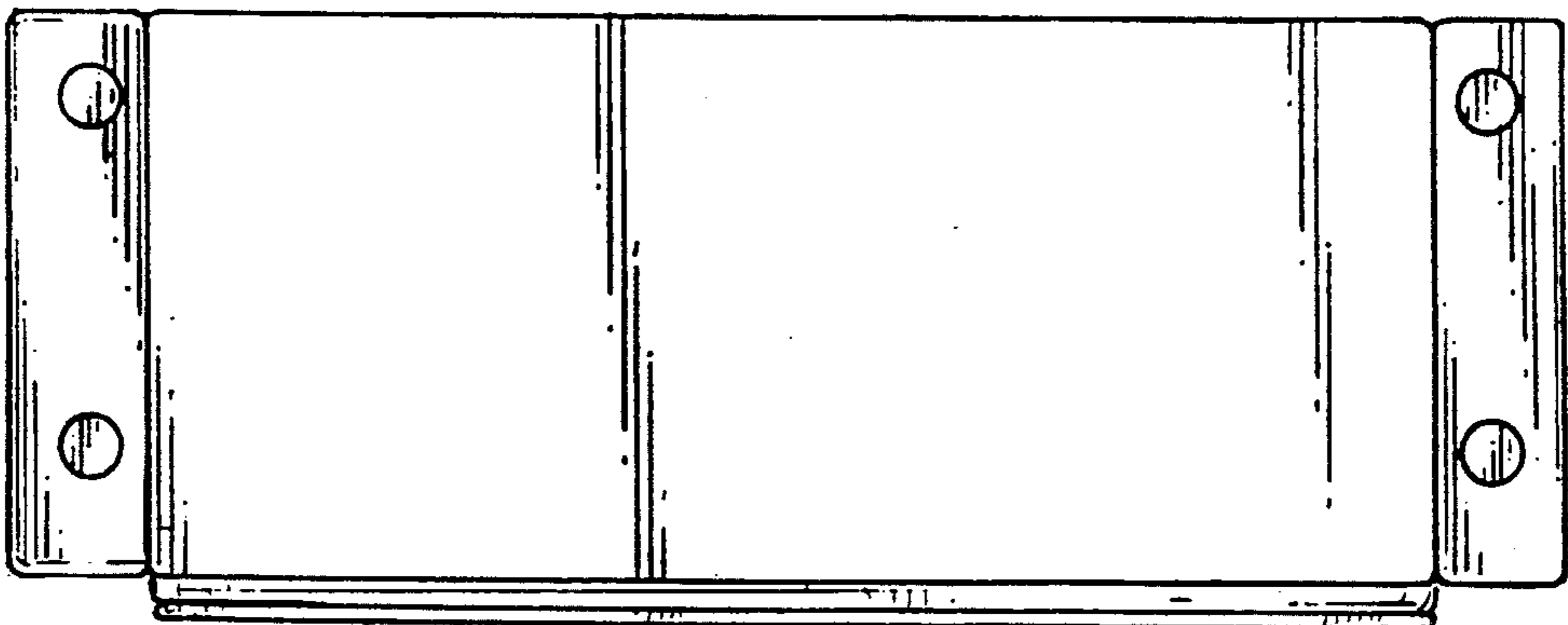

FIG. 15

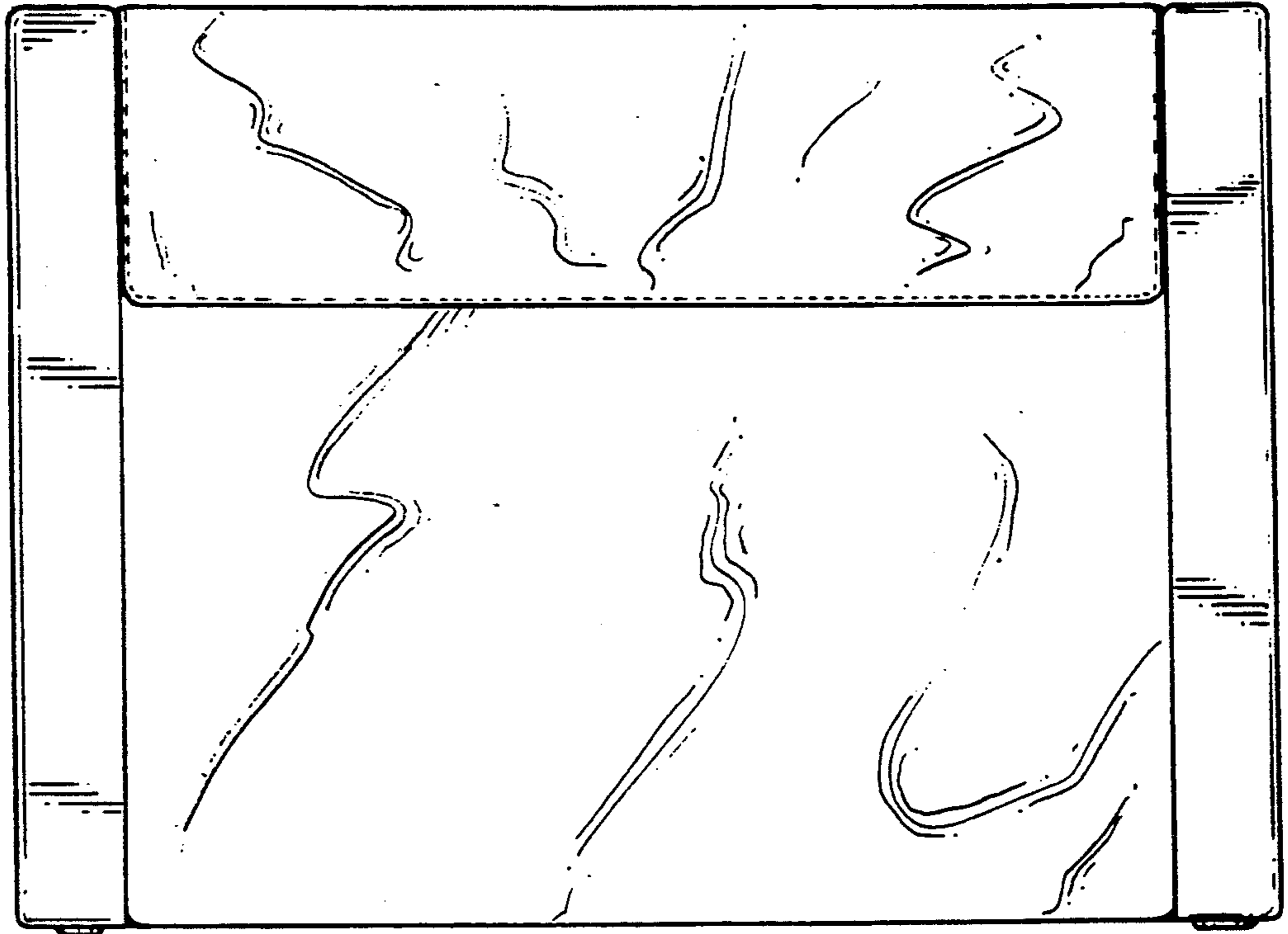

FIG. 16

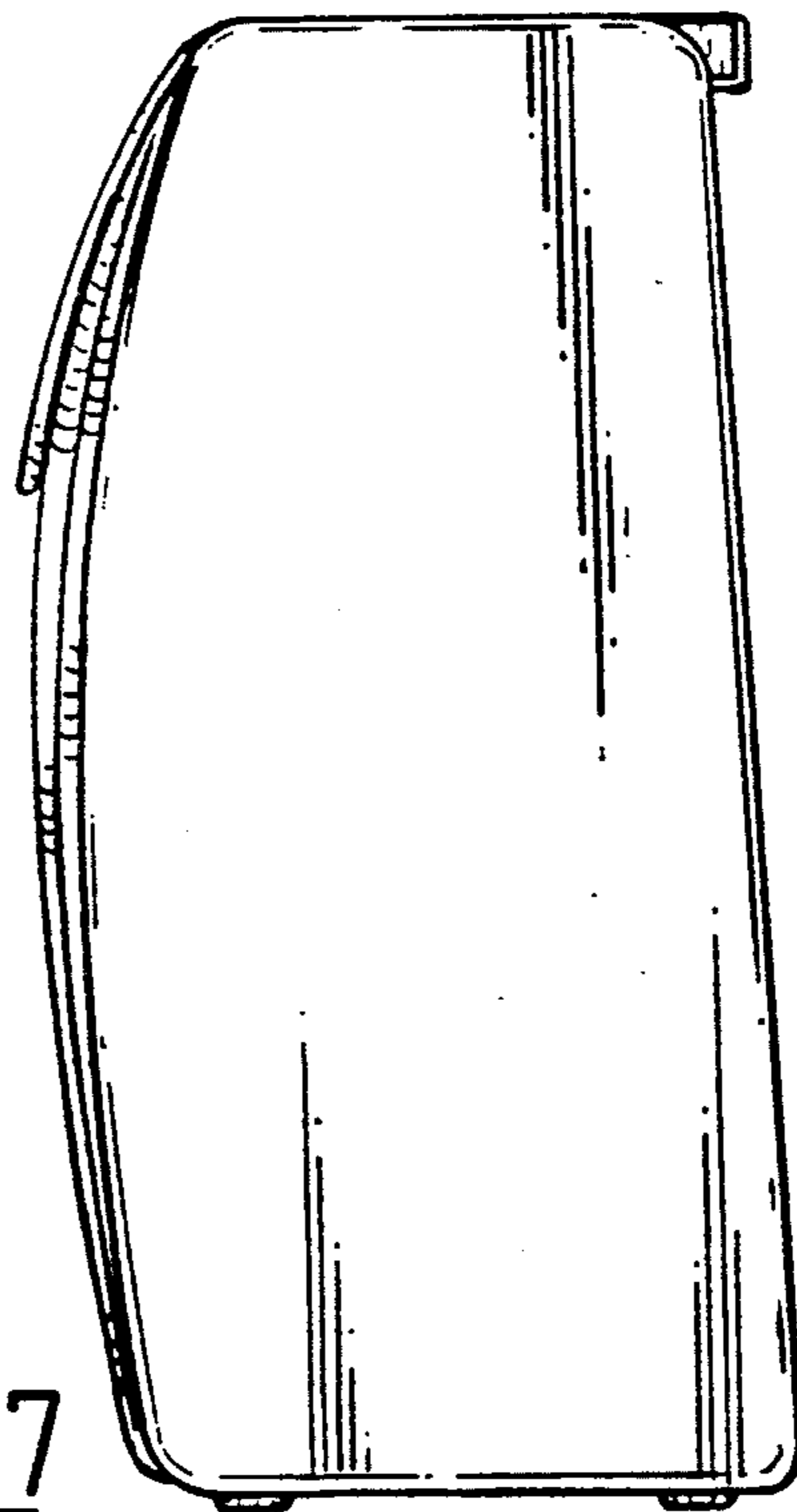

FIG. 17

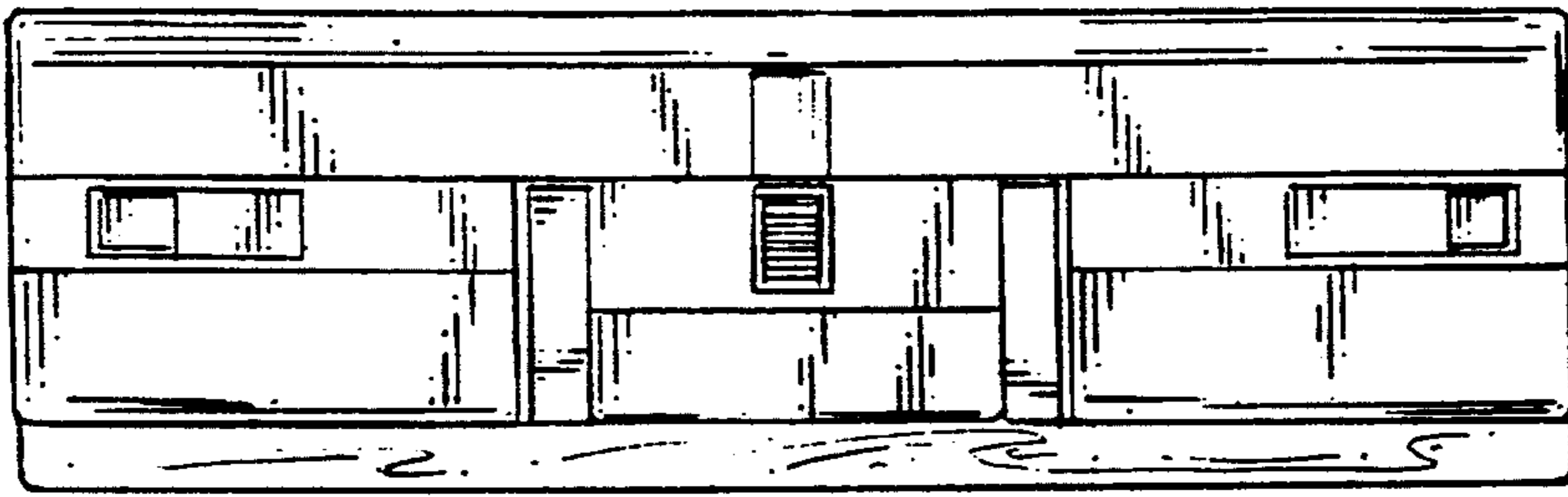

FIG. 18

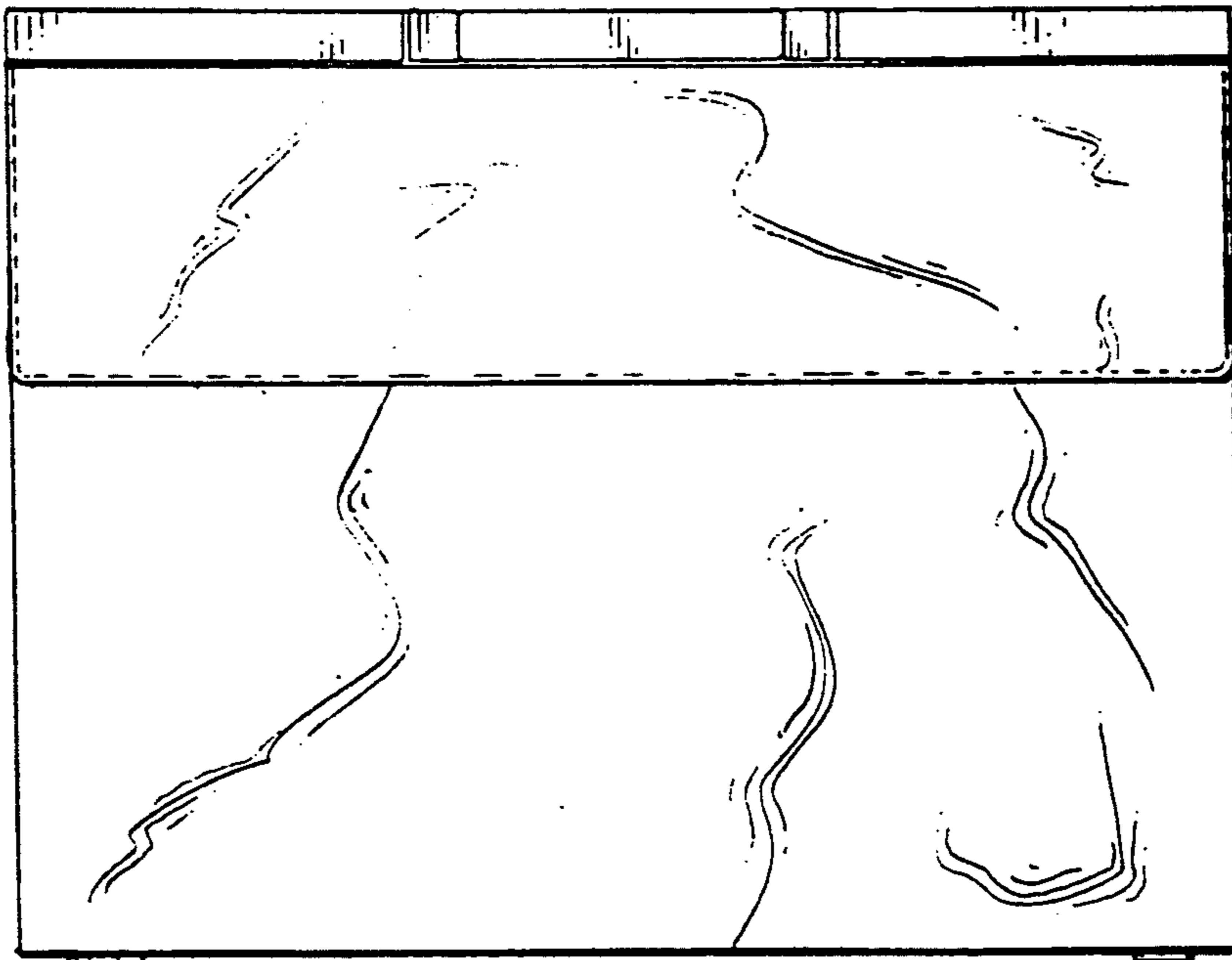

FIG. 19

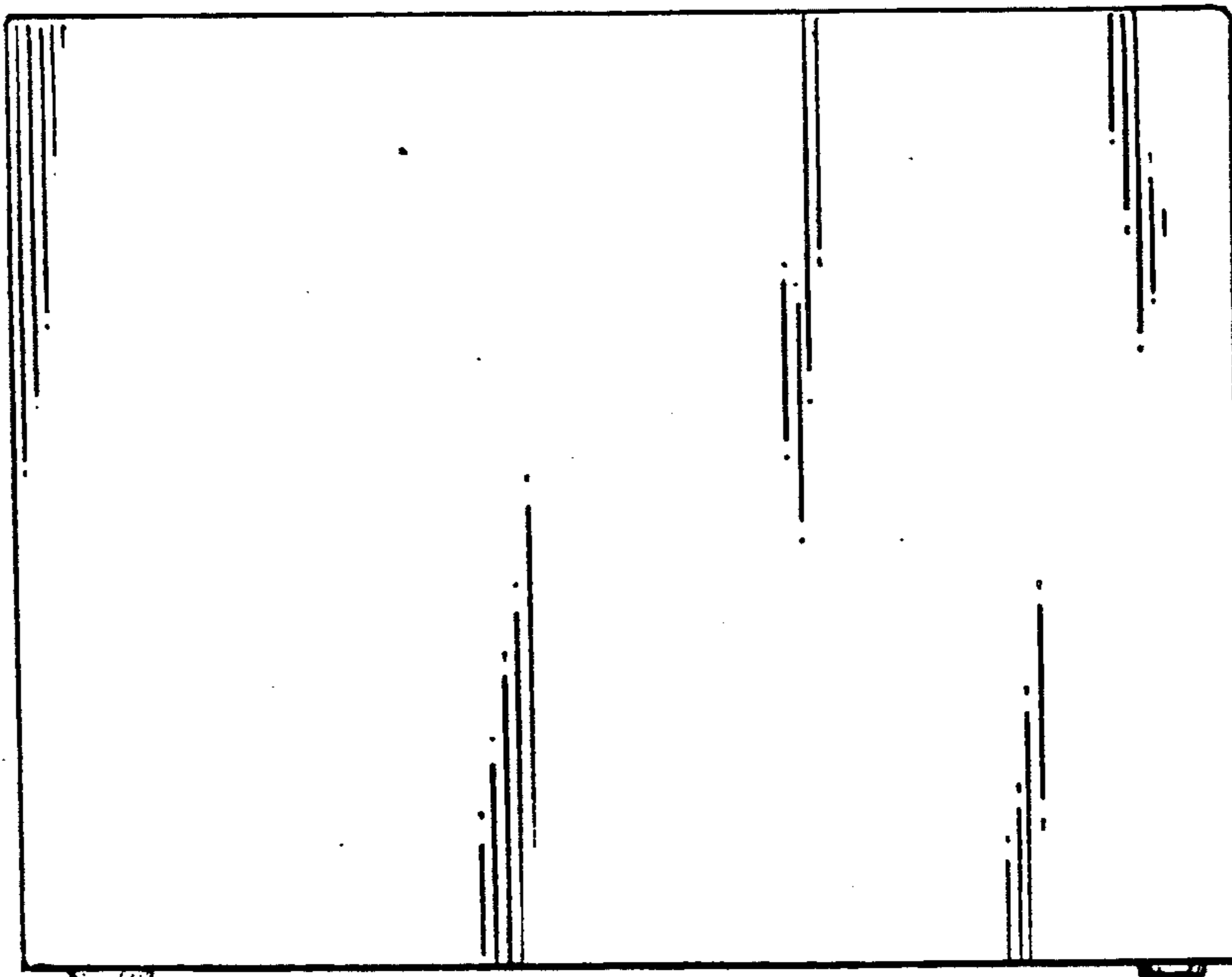

FIG. 20

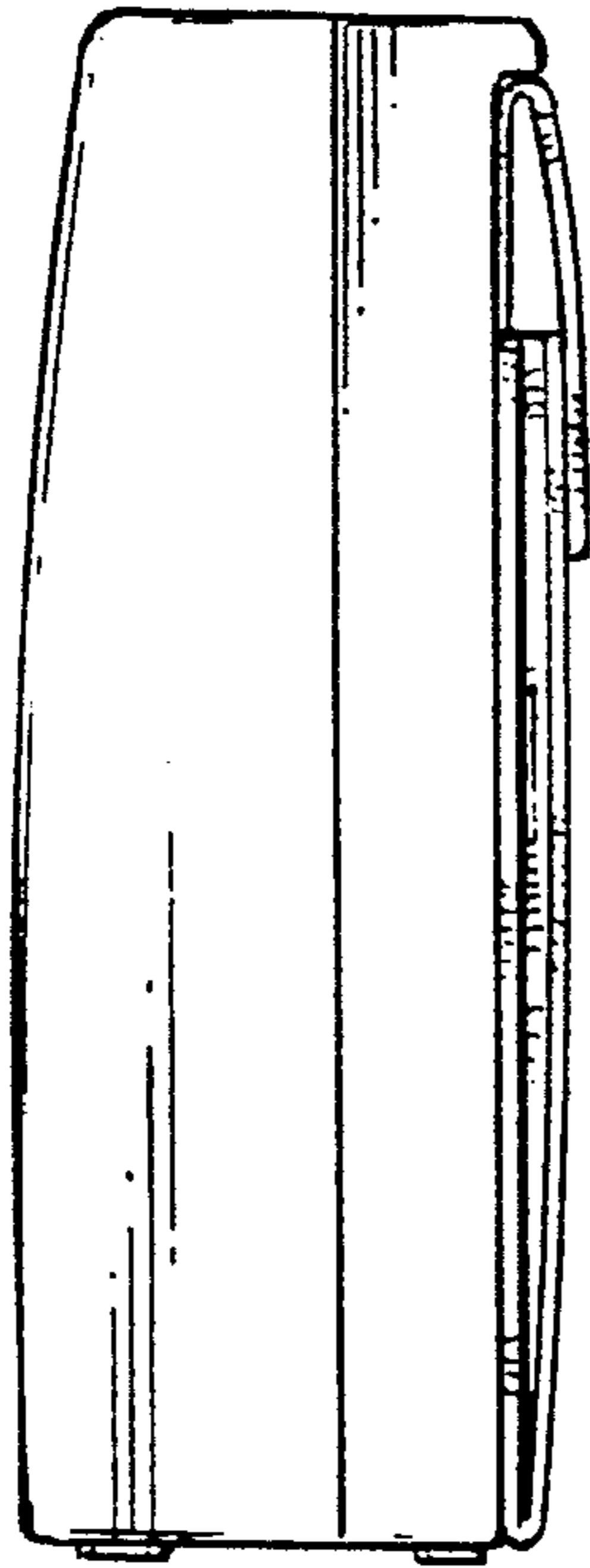

FIG. 21

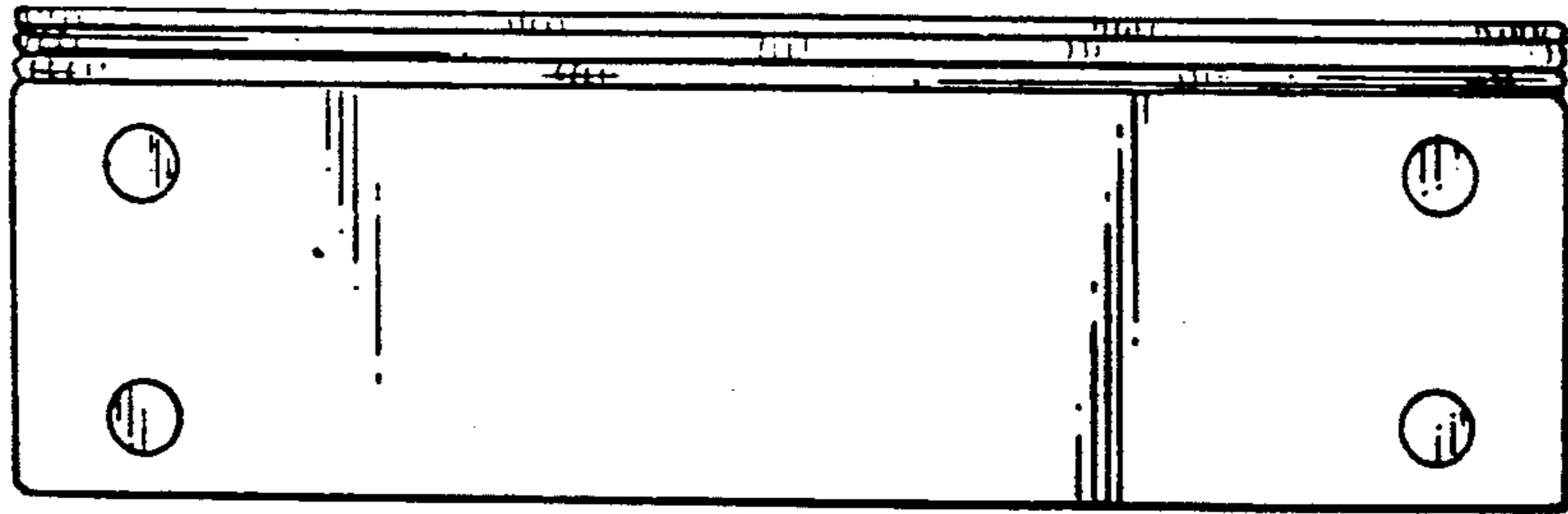

FIG. 22