



US00D328610S

United States Patent [19]

[11] Patent Number: Des. 328,610

Walker

[45] Date of Patent: ** Aug. 11, 1992

[54] ORGANIZING AND PLANNING BOOK FOR ATTACHMENT TO A VEHICLE WINDSHIELD

Primary Examiner—James M. Gandy
Attorney, Agent, or Firm—Leon Gildea

[76] Inventor: Leon I. Walker, 4819 S. Greenwood, Chicago, Ill. 60615

[57] CLAIM

[**] Term: 14 Years

The ornamental design for an organizing and planning book for attachment to a vehicle windshield, as shown and described.

[21] Appl. No.: 544,343

DESCRIPTION

[22] Filed: Jun. 27, 1990

[52] U.S. Cl. D19/26

[58] Field of Search D19/26-31;
D3/30.1; D12/155, 191; 40/643; 281/45, 37,
29, 31, 36, 78, 79; 402/500

FIG. 1 is a front elevational view of the organizing and planning book for attachment to a vehicle windshield showing my new design;

FIG. 2 is a rear elevational view thereof;

FIG. 3 is an enlarged left side elevational view thereof;

FIG. 4 is an enlarged right side elevational view thereof;

FIG. 5 is an enlarged top plan view thereof;

FIG. 6 is an enlarged bottom plan view thereof; and,

FIG. 7 is a slightly enlarged perspective view thereof in open condition.

The broken line showing of environmental indica in FIG. 1 of the drawing is for illustrative purposes only and forms no part of the claimed design.

[56] References Cited

U.S. PATENT DOCUMENTS

D. 215,535	9/1969	Tucker	D19/264
D. 312,275	11/1990	Wyant	D19/26
1,434,750	11/1922	Pratt	D12/191 X
2,528,590	11/1950	Garlow	D12/155 X
2,733,763	9/1952	Nygaard	D12/191 X
4,306,737	12/1981	Errichiello	281/31 X

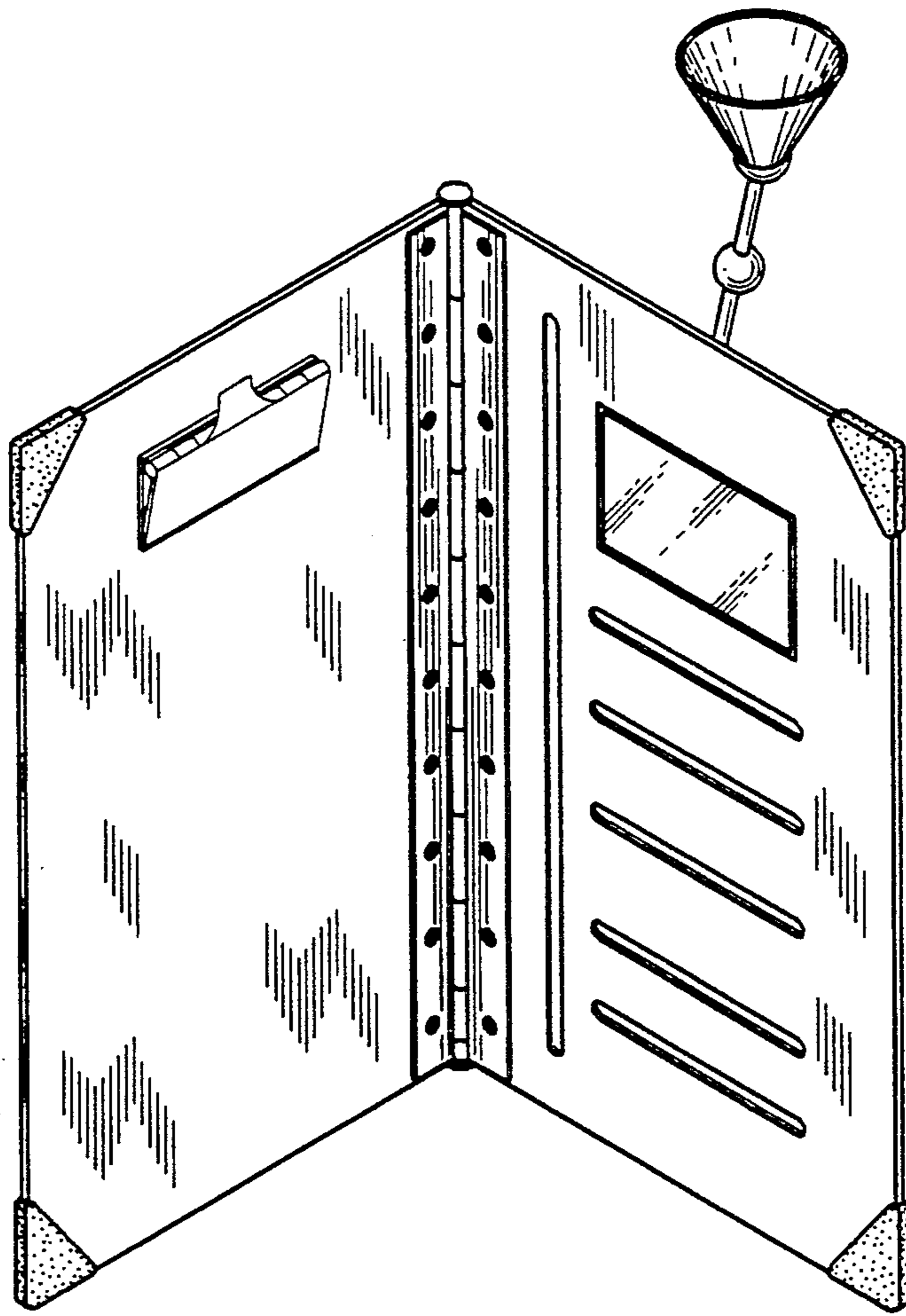

FIG. 1

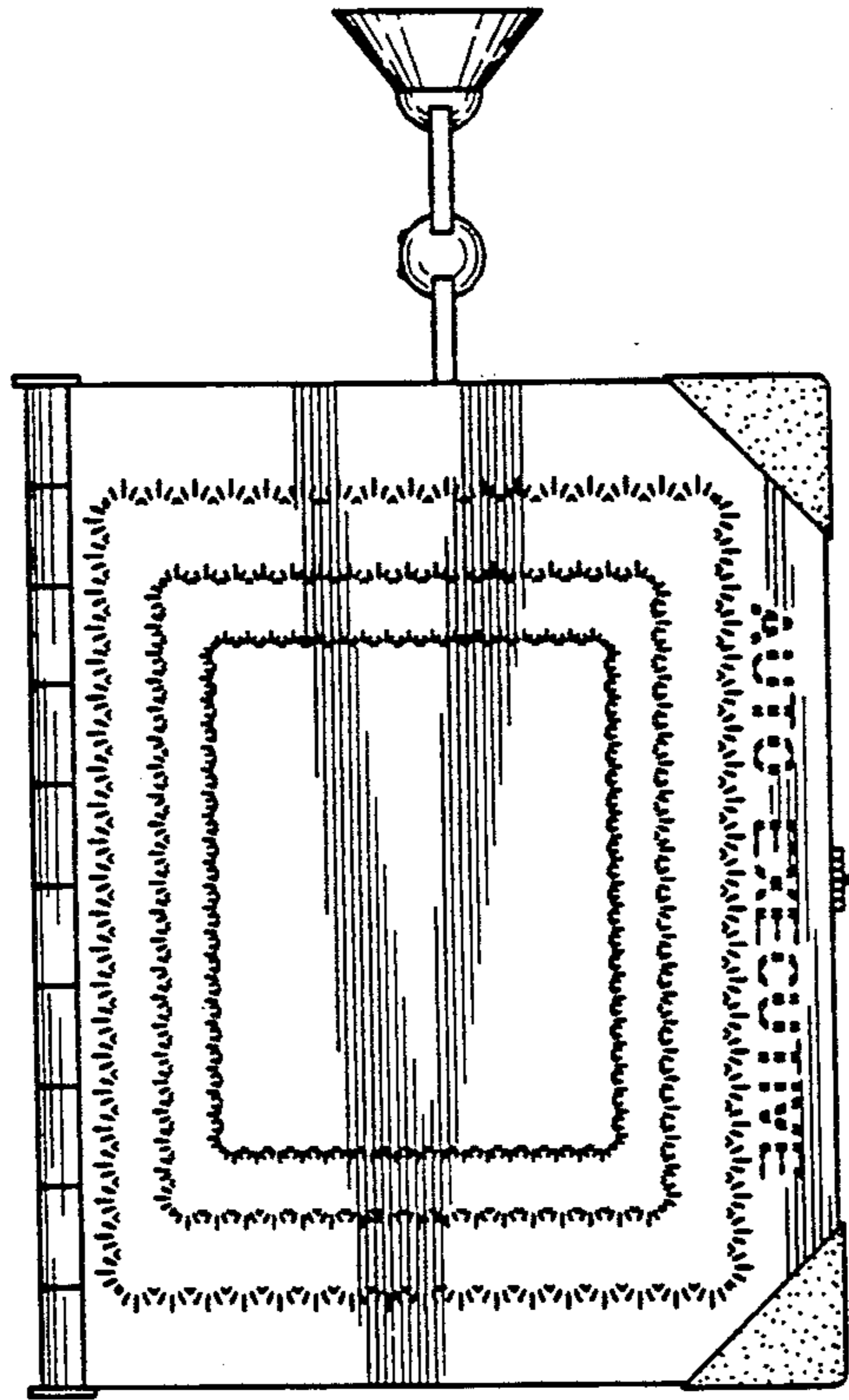

FIG. 2

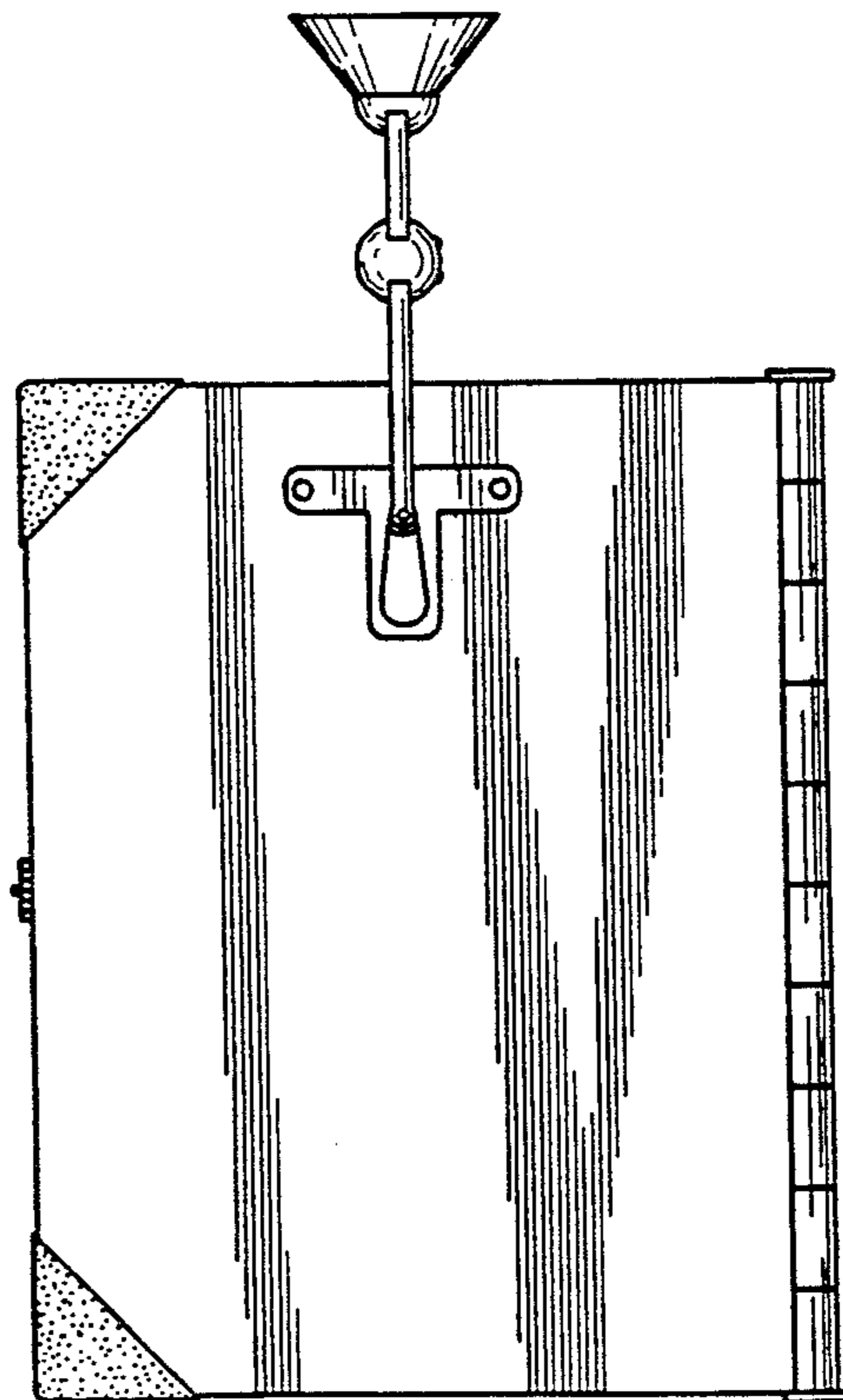

FIG. 3

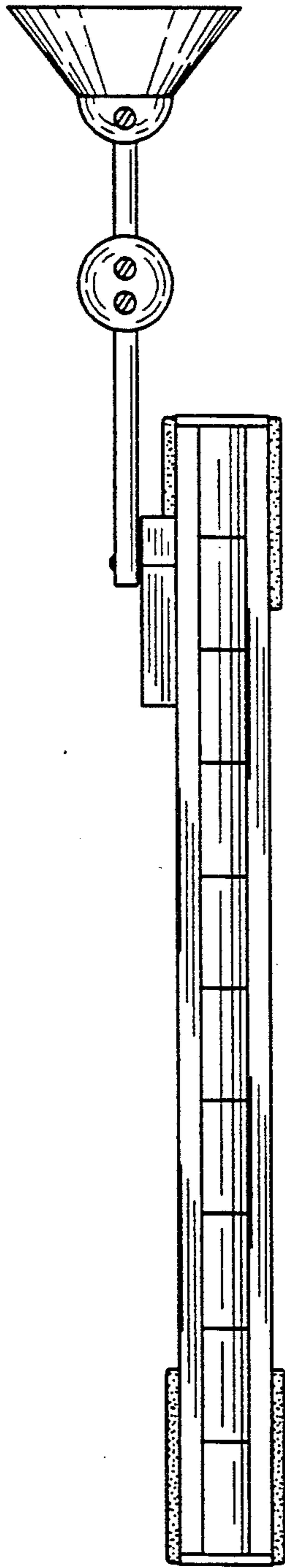

FIG. 4

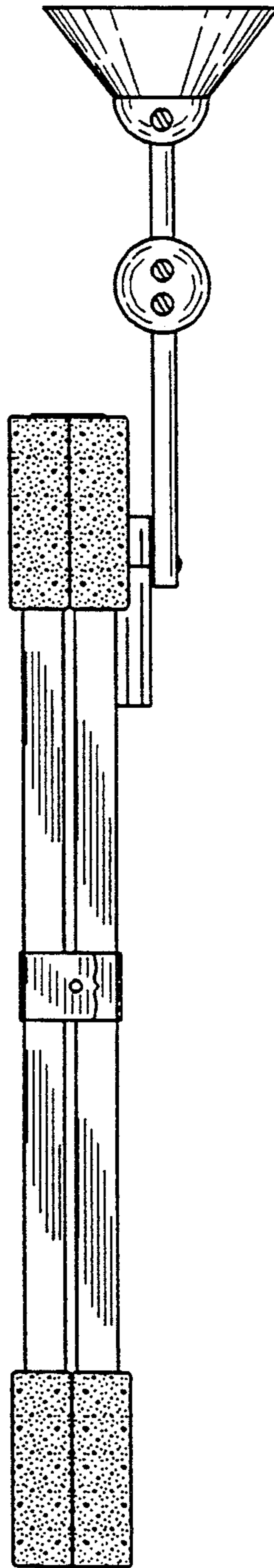

FIG. 5

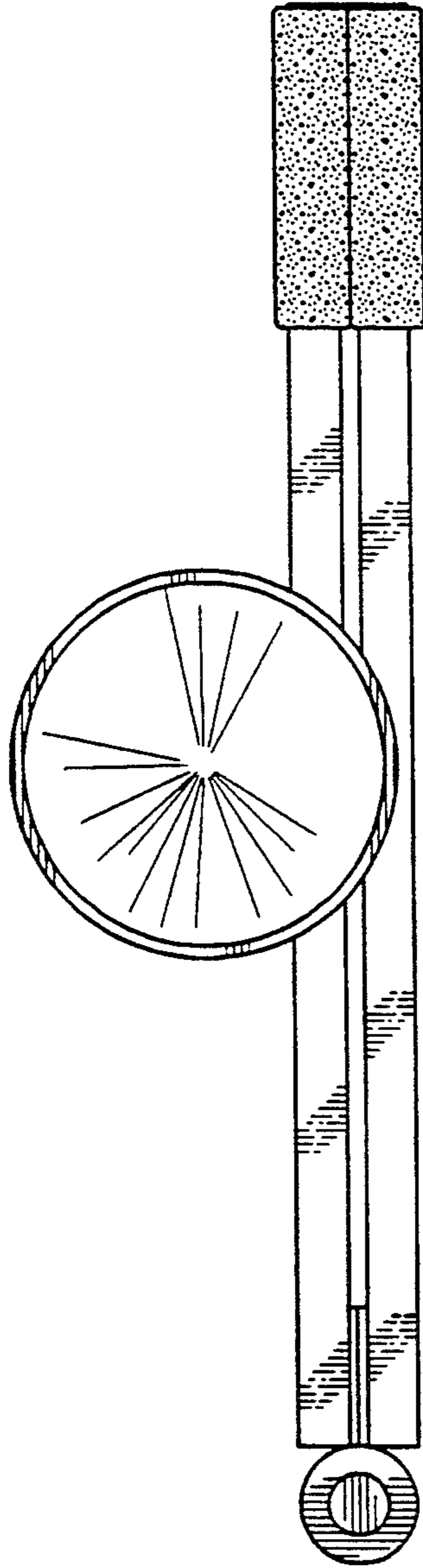

FIG. 6

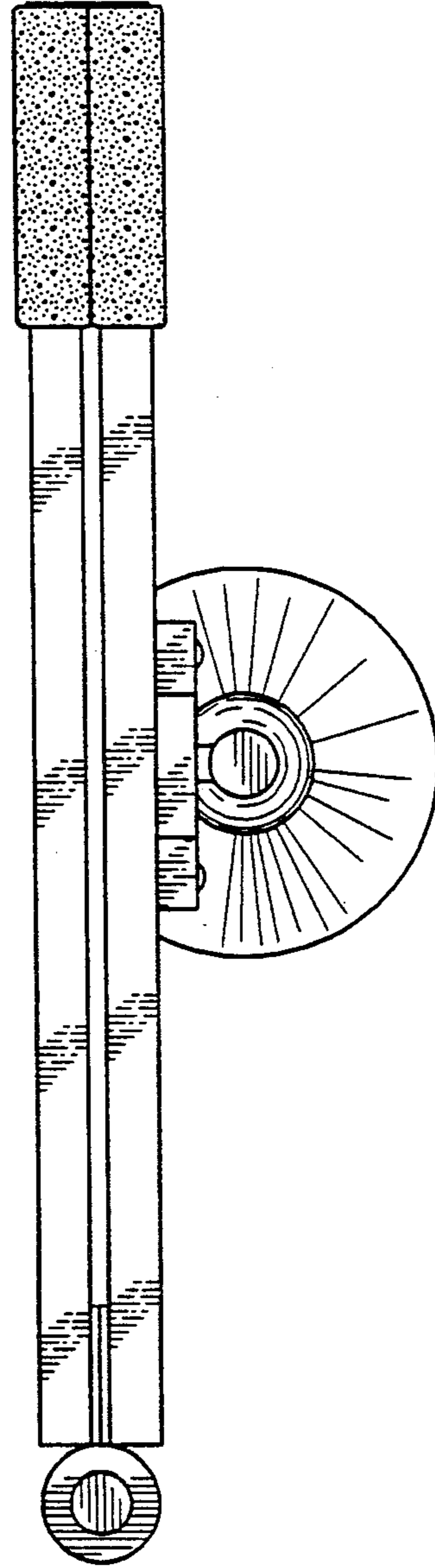

FIG. 7

