



US00D328479S

# United States Patent [19]

[11] Patent Number: **Des. 328,479**

Wakimura

[45] Date of Patent: **\*\* Aug. 4, 1992**

[54] TOY CAR

D. 293,258 12/1987 Hoshiro ..... D21/136  
D. 311,760 10/1990 Harrod ..... D21/136

[75] Inventor: **Kakuichi Wakimura, Tokyo, Japan**

[73] Assignee: **Mitsuwa Kogyo Co., Ltd., Tokyo, Japan**

[\*\*] Term: **14 Years**

[21] Appl. No.: **586,016**

[22] Filed: **Sep. 20, 1990**

[52] U.S. Cl. .... **D21/136**

[58] Field of Search ..... **D21/128, 129, 131, 134, D21/135, 136, 137, 140; D12/1, 3, 14, 97; 446/94, 426, 427, 433, 460, 467**

### OTHER PUBLICATIONS

Hong Kong Toys 1989 p. 724.

*Primary Examiner*—Bernard Ansher

*Assistant Examiner*—R. Barkai

*Attorney, Agent, or Firm*—Fulwider, Patton, Lee & Utecht

### [57] CLAIM

The ornamental design for a toy car, as shown and described.

### DESCRIPTION

FIG. 1 is a top plan view of a toy car showing my new design;

FIG. 2 is a bottom plan view thereof;

FIG. 3 is a left side elevational view thereof;

FIG. 4 is a right side elevational view thereof;

FIG. 5 is a front elevational view thereof; and,

FIG. 6 is a rear elevational view thereof.

### [56] References Cited

#### U.S. PATENT DOCUMENTS

D. 203,843 2/1966 Campbell ..... D21/136  
D. 262,224 12/1981 Aoki ..... D21/128  
D. 262,564 1/1982 Yamashina ..... D21/136  
D. 266,008 8/1982 Klawitter ..... D21/136  
D. 266,097 10/1982 Klawitter ..... D21/136

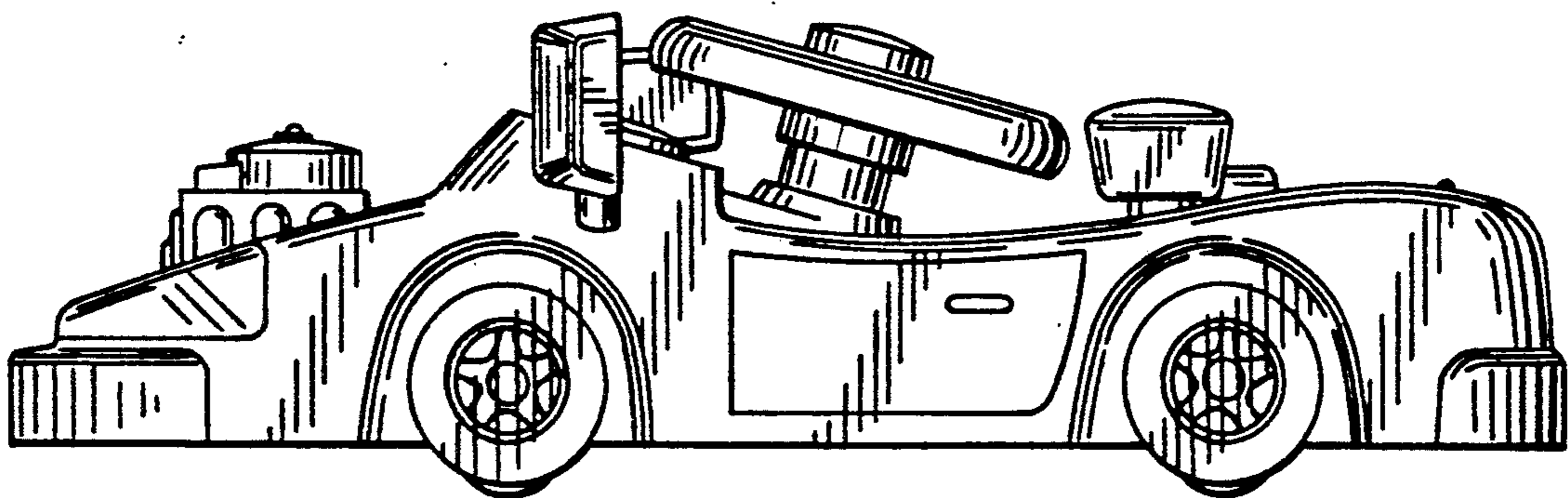

FIG. 1

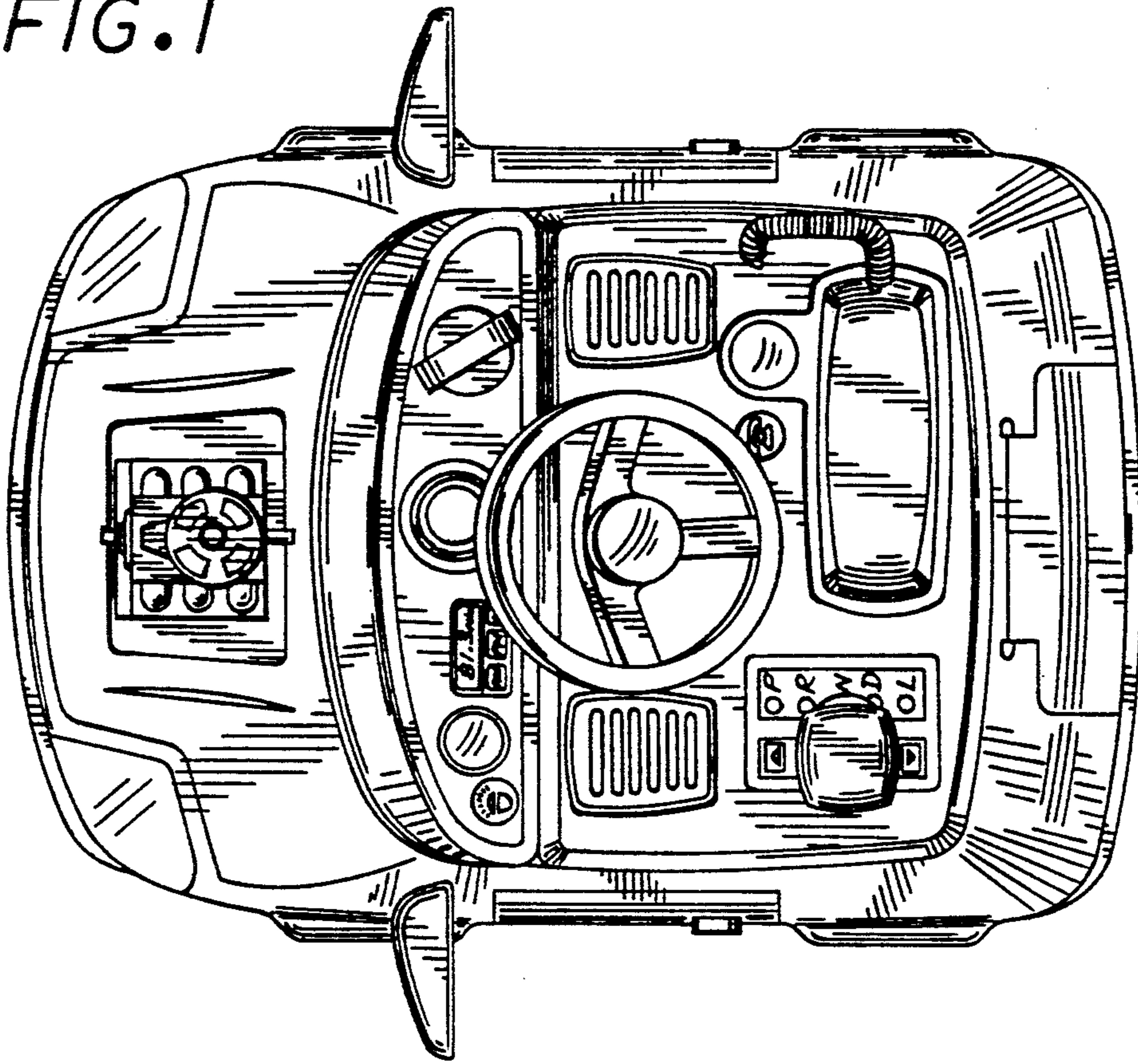
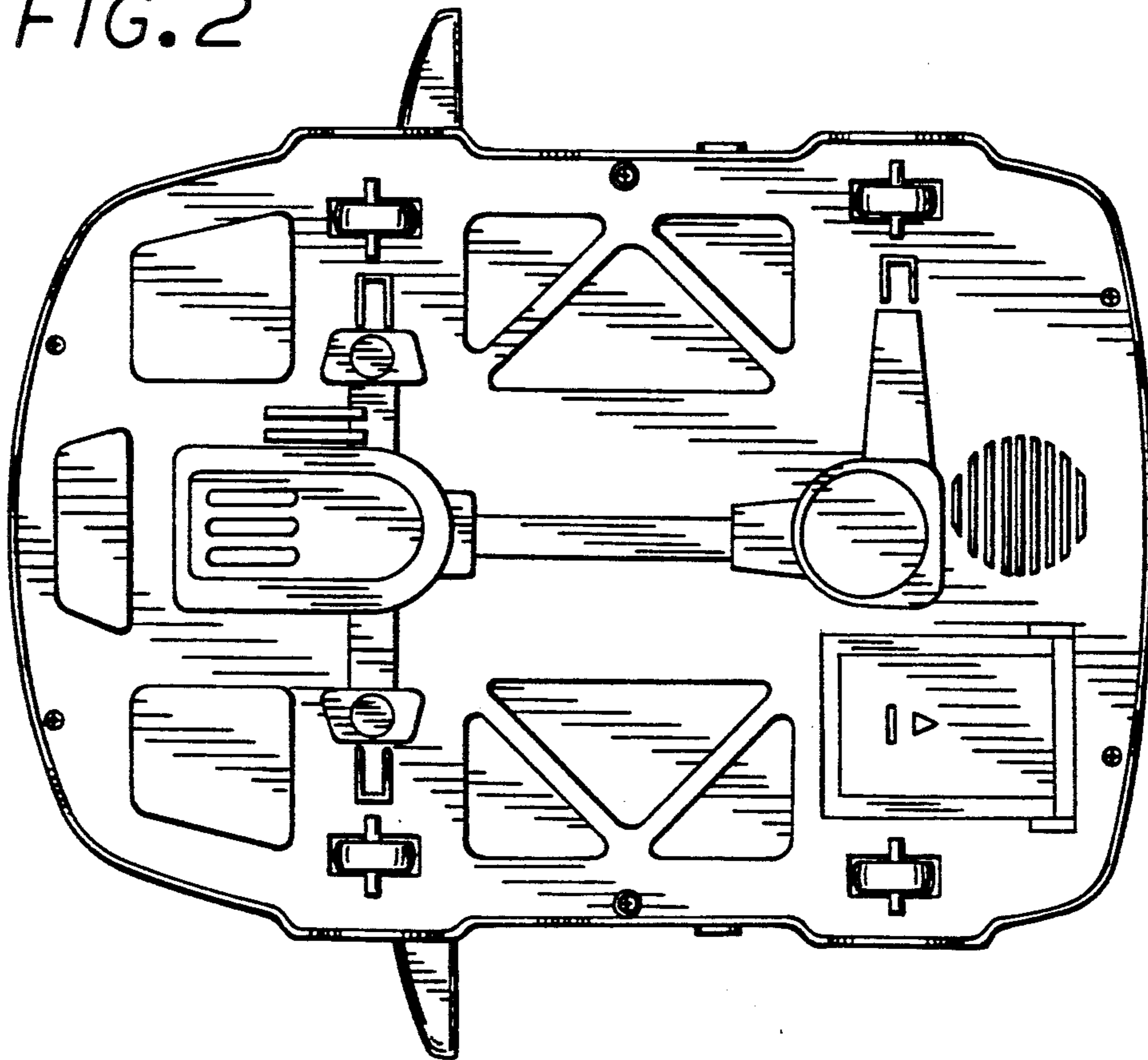

FIG. 2



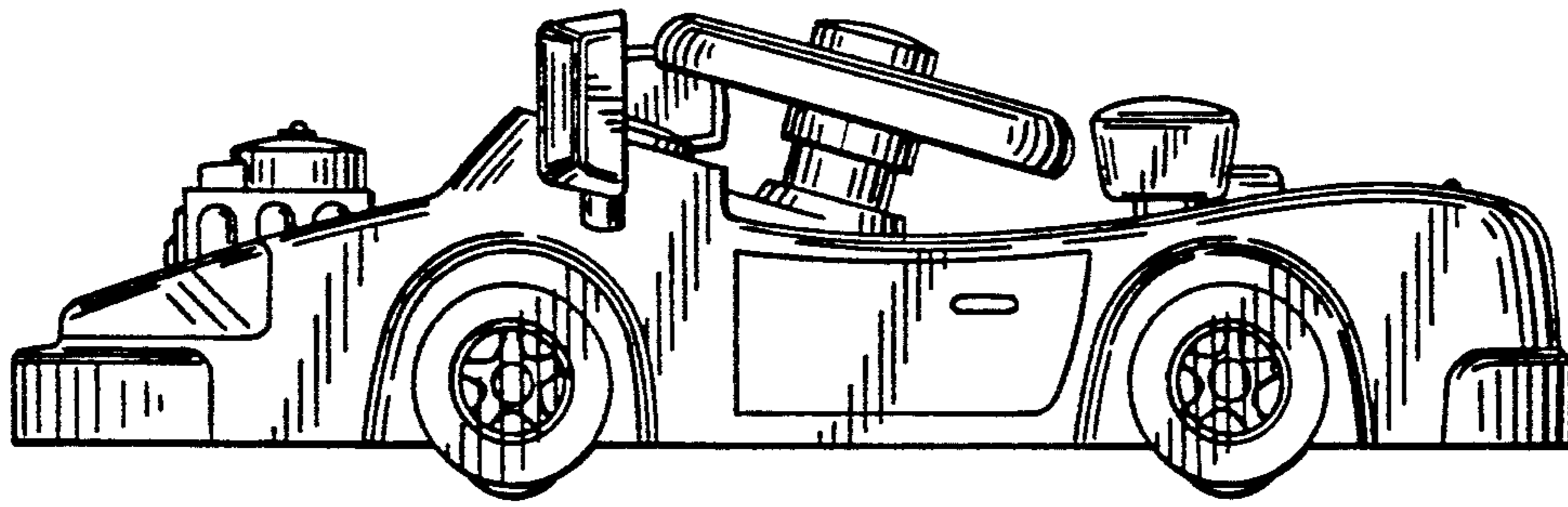

FIG. 3

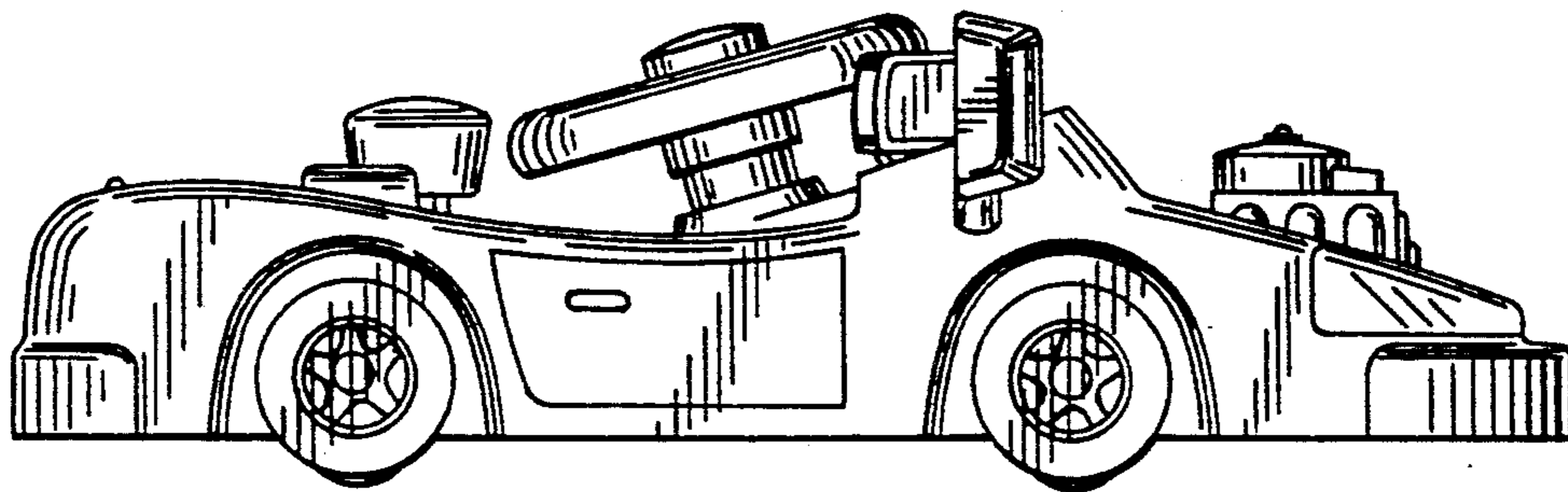

FIG. 4

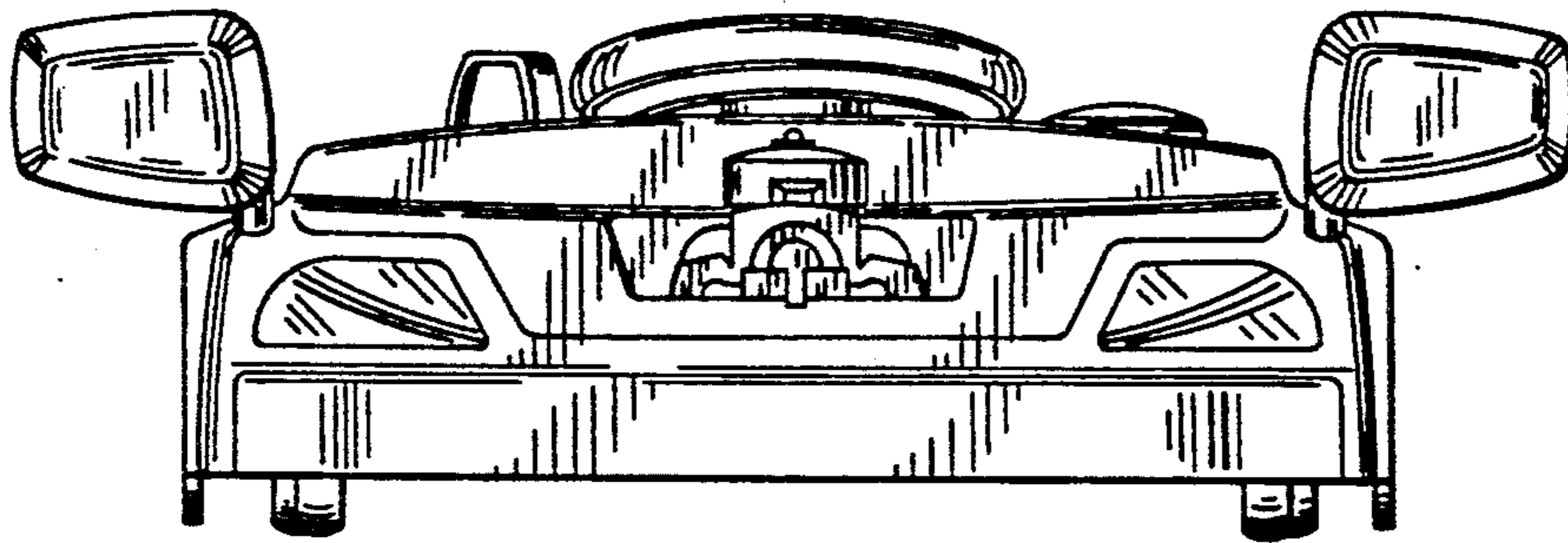

FIG. 5

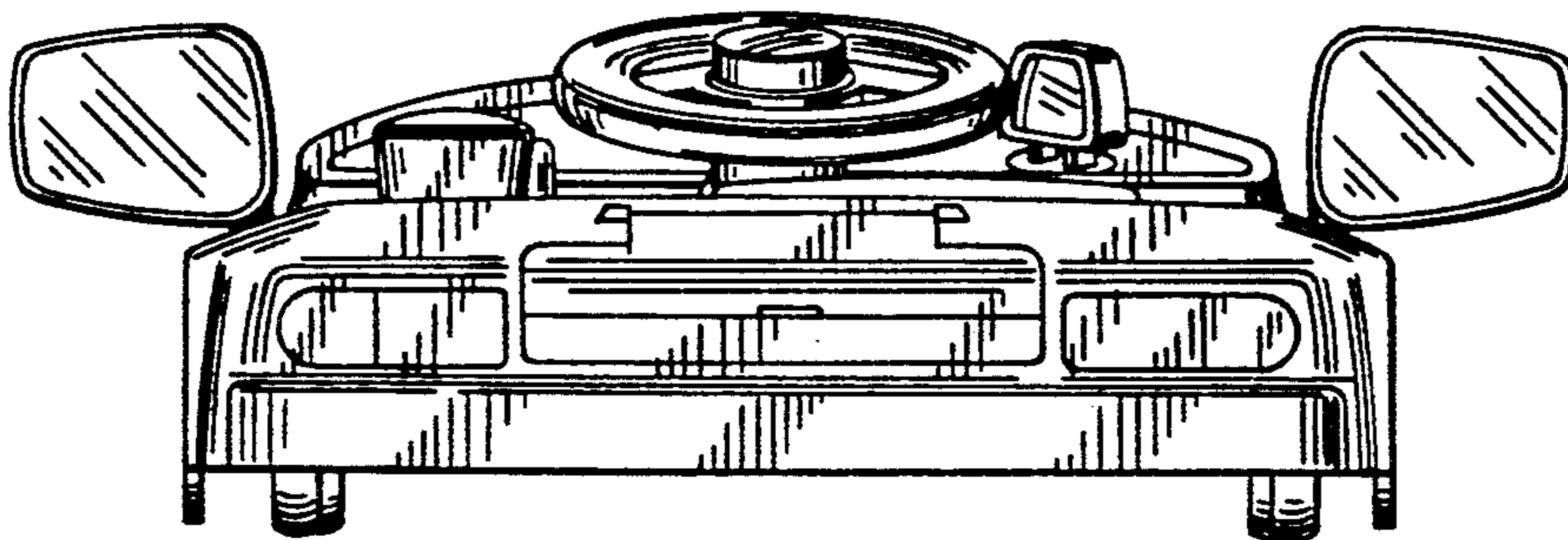

FIG. 6