



US00D328477S

United States Patent [19]

McKinney

[11] Patent Number: **Des. 328,477**

[45] Date of Patent: **** Aug. 4, 1992**

[54] CONVERTIBLE SCOOTER/WAGON

[75] Inventor: **James C. McKinney**, Somerset, N.J.

[73] Assignee: **What Not, Inc.**, Fed. Rep. of Germany

[**] Term: **14 Years**

[21] Appl. No.: **532,979**

[22] Filed: **Jun. 4, 1990**

[52] U.S. Cl. **D21/71**

[58] Field of Search **D21/71, 80, 81, 108, D21/124, 128, 134, 135, 141; 280/87.041, 828, 1.13, 1.22, 87.043, 87.01; 446/95, 128, 440**

[56] **References Cited**

U.S. PATENT DOCUMENTS

D. 136,950	1/1944	Dodson	D21/134
D. 137,962	5/1944	Patner	280/87.043
D. 146,061	12/1946	Patner	280/87.043
D. 163,401	5/1951	McGuire et al.	280/87.043
1,006,708	10/1911	Yost	280/87.043
1,318,847	10/1919	Clockers	280/87.043
1,345,322	6/1920	Foans	280/30
1,560,288	11/1925	Murvay	280/30
1,637,614	8/1927	Kohler	280/87.043
1,657,529	1/1928	Erni	280/87.01
1,698,165	1/1929	Martin	280/87.043
1,773,567	8/1930	Bradley	280/87.043
1,806,961	5/1931	Waas	280/87.043

3,244,593	1/1981	Malone	280/87.01
4,958,843	9/1990	Cole	280/30

FOREIGN PATENT DOCUMENTS

433998	10/1967	Switzerland	280/7.14
--------	---------	-------------	-------	----------

Primary Examiner—Bernard Ansher
Assistant Examiner—R. Barkai
Attorney, Agent, or Firm—Connelly & Hutz

[57] CLAIM

The ornamental design for a convertible scooter/wagon, as shown and described.

DESCRIPTION

FIG. 1 is a side elevational view of a convertible scooter/wagon in the wagon condition showing my new design, the side opposite being a mirror image;
 FIG. 2 is a top plan view thereof;
 FIG. 3 is a bottom plan view thereof;
 FIG. 4 is a front elevational view thereof;
 FIG. 5 is a rear elevational view thereof;
 FIG. 6 is a side elevational view thereof in its scooter condition;
 FIG. 7 is a top plan view thereof in the scooter condition;
 FIG. 8 is a front elevational view thereof in the scooter condition; and,
 FIG. 9 is an enlarged cross-sectional view taken through FIG. 7 along the line 9—9.

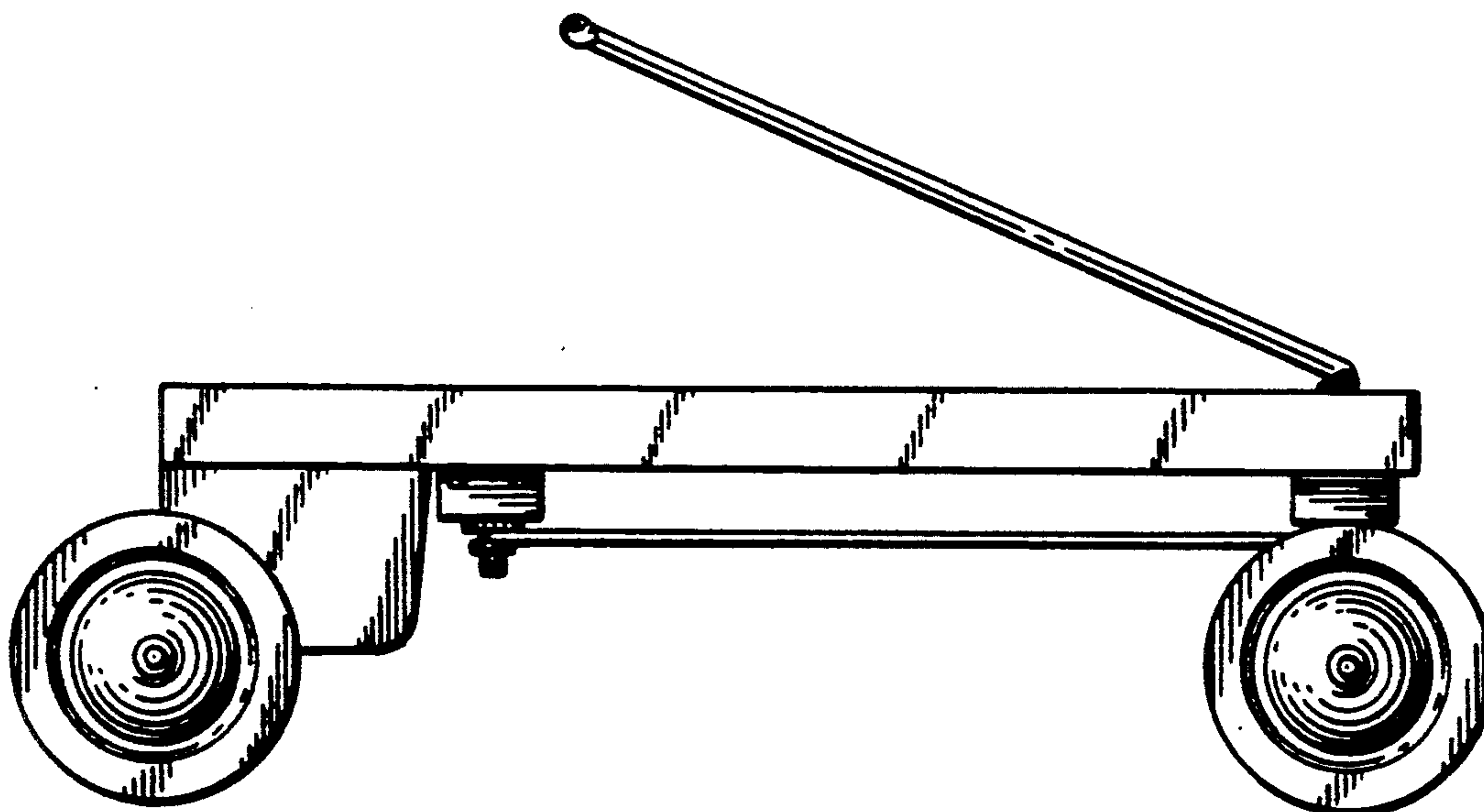

Fig. 2.

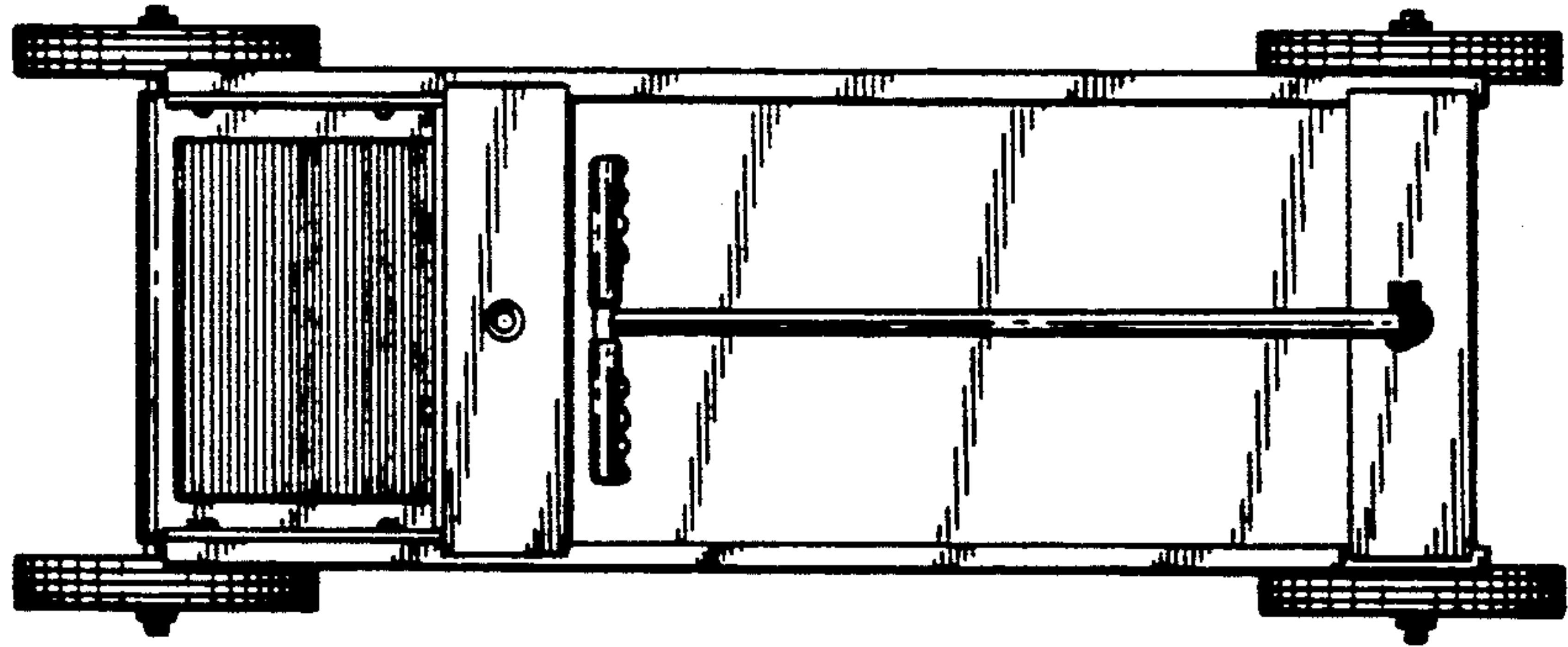

Fig. 1.

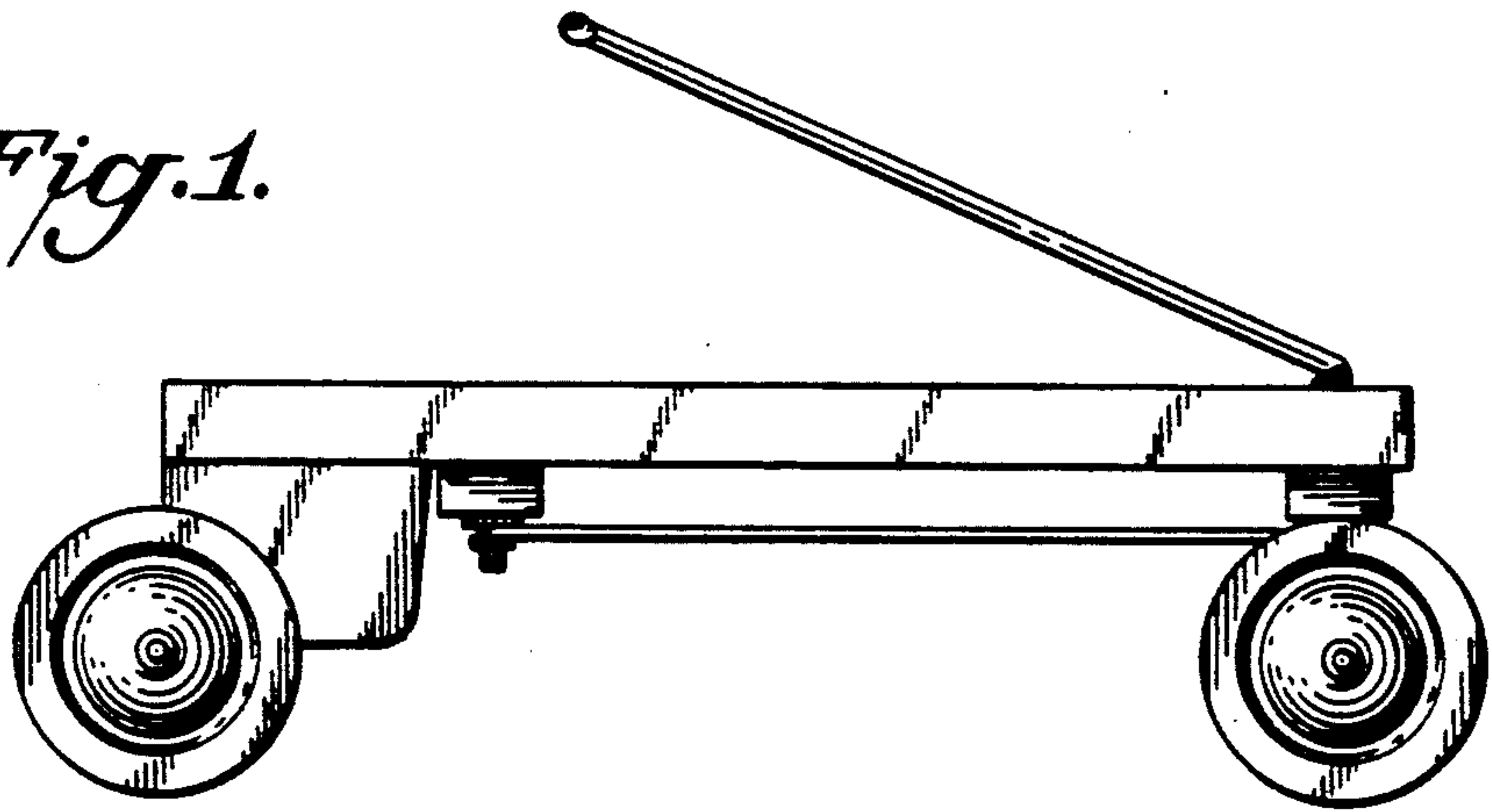

Fig. 3.

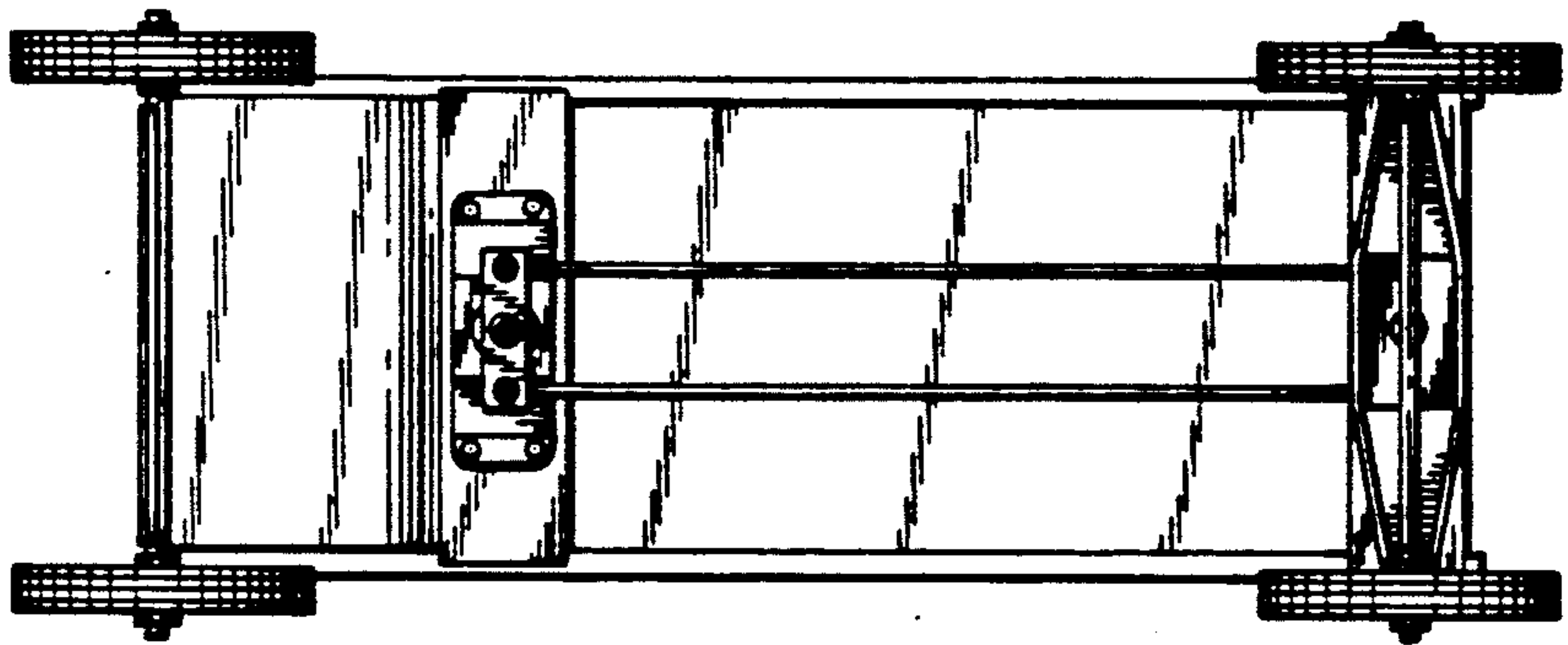

Fig. 4.

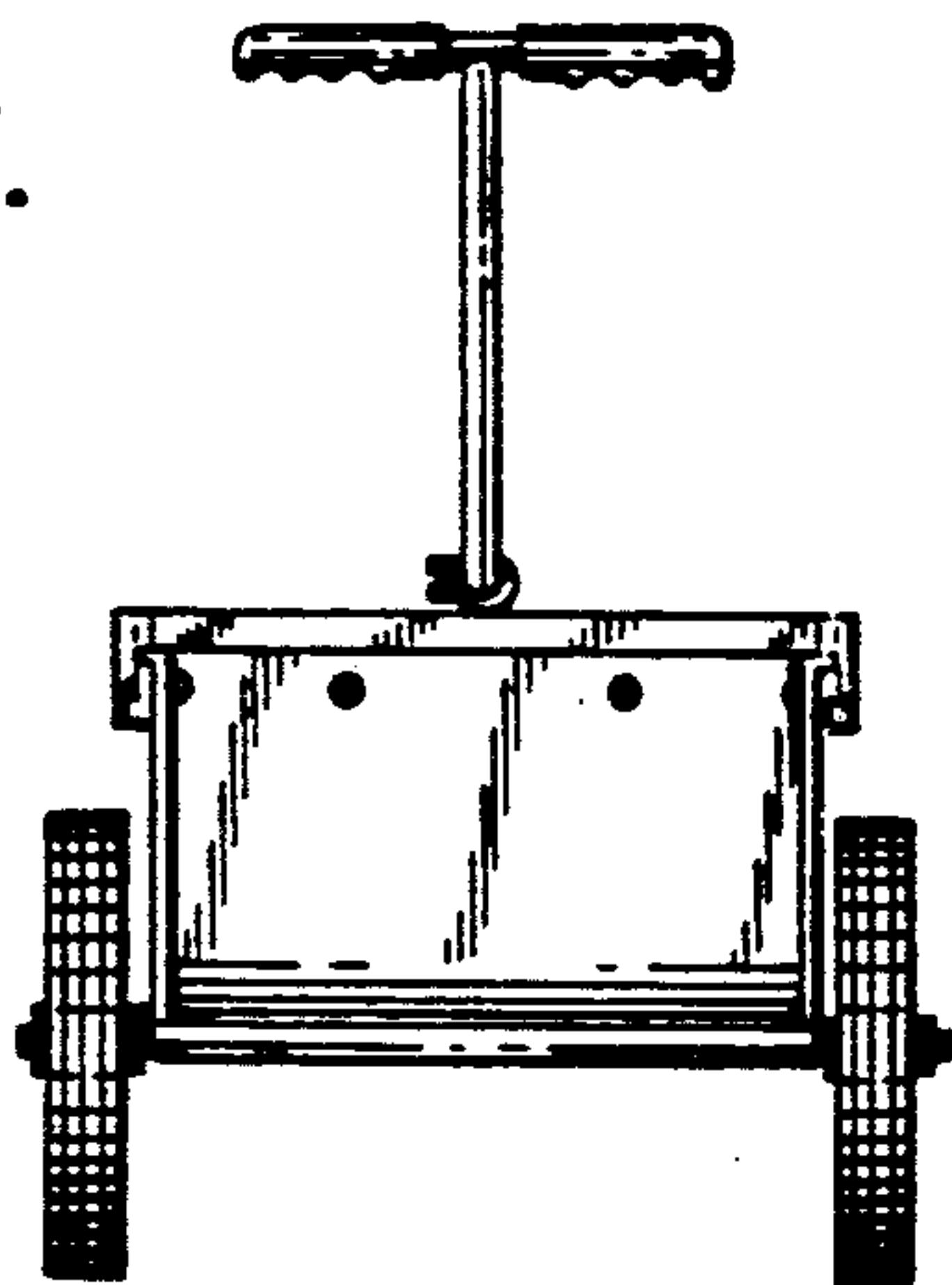

Fig. 5.

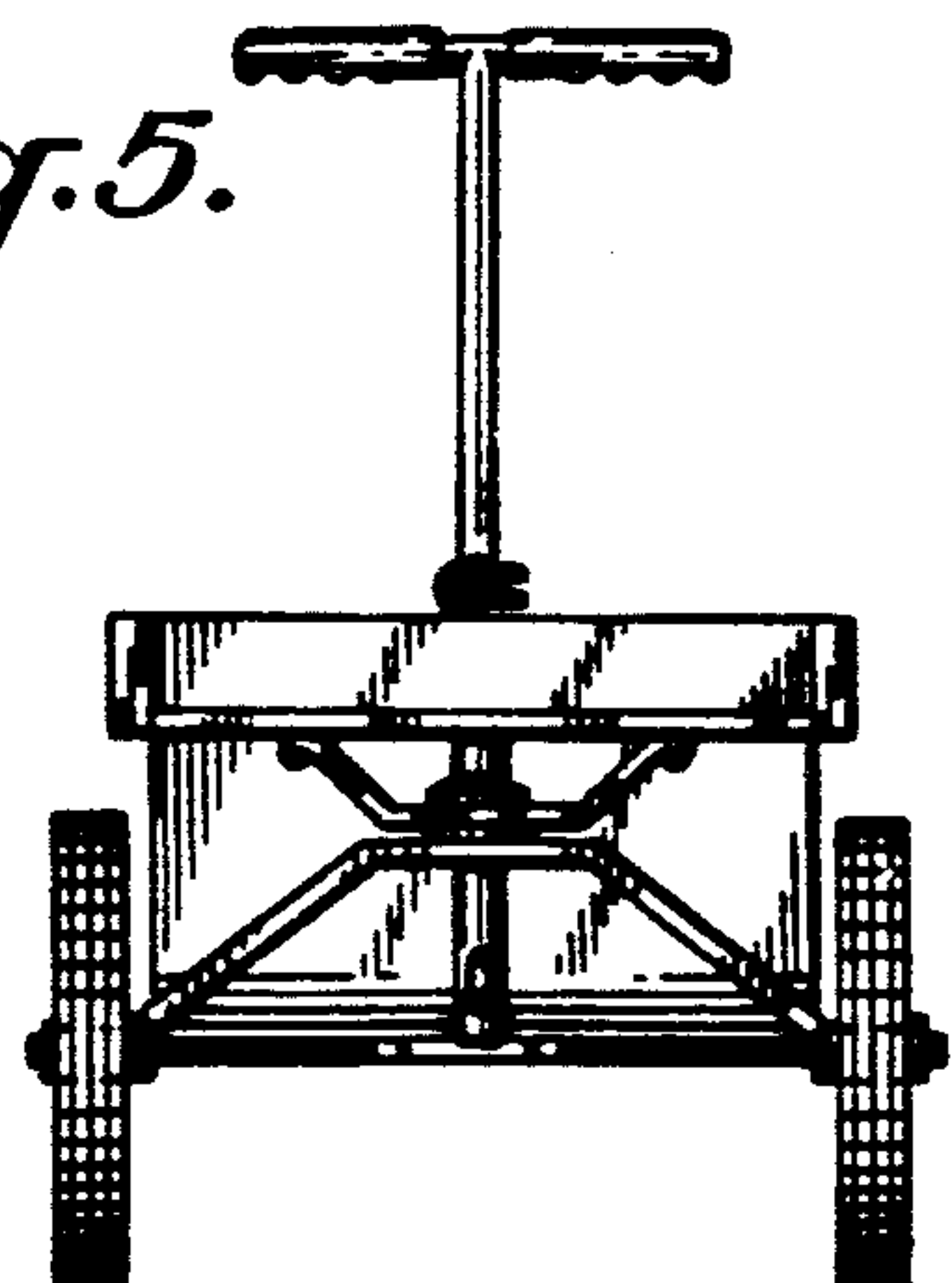

Fig. 7.

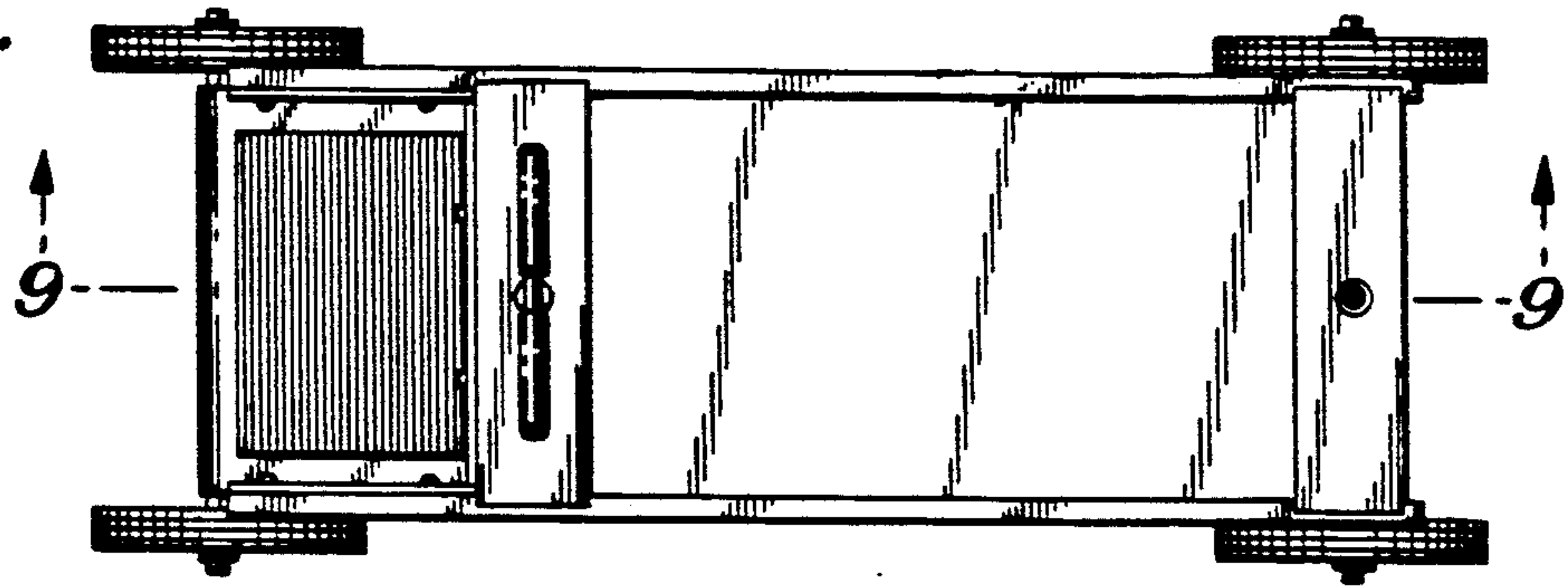

Fig. 6.

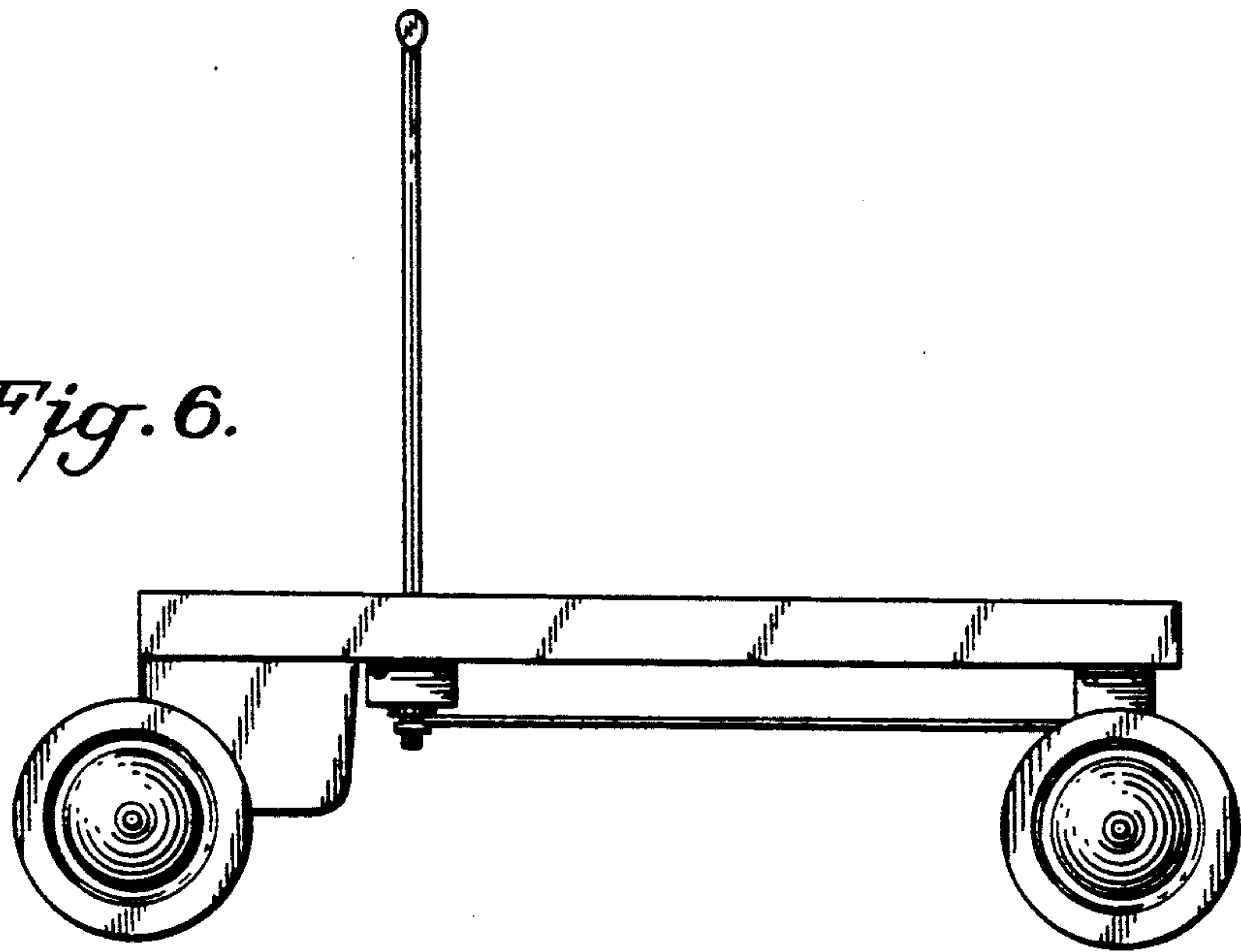

Fig. 8.

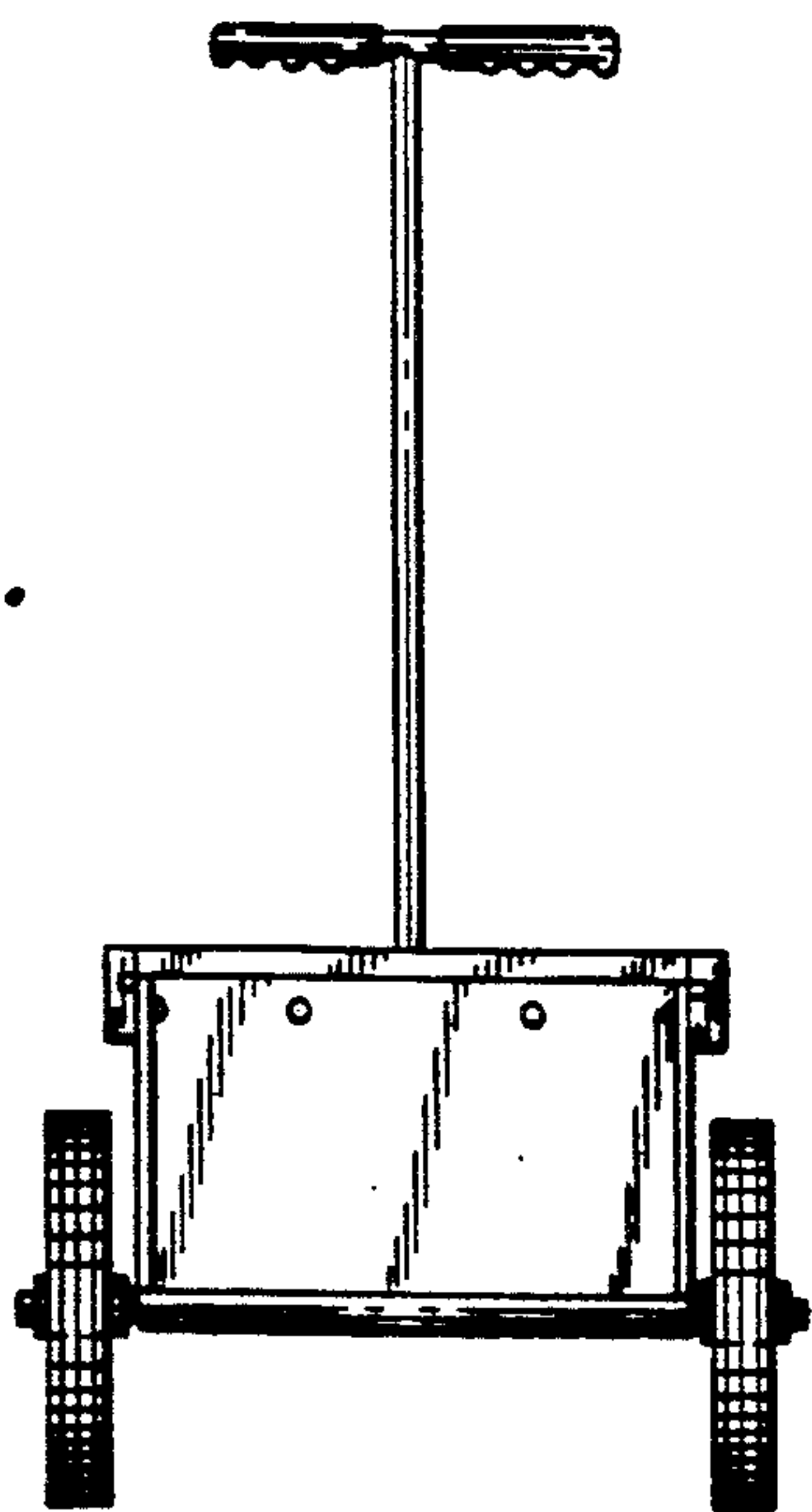

Fig. 9.

