



US00D328020S

United States Patent [19]

[11] Patent Number: **Des. 328,020**

Wang

[45] Date of Patent: *** Jul. 21, 1992**

[54] **AUTOMOBILE STEERING WHEEL LOCK**

[76] Inventor: **Ching R. Wang**, No. 27, Alley 74, Lane 313, Wen-Hsien Road, Tainan, Taiwan

[*] Notice: The portion of the term of this patent subsequent to Nov. 20, 2004 has been disclaimed.

[**] Term: **14 Years**

[21] Appl. No.: **522,971**

[22] Filed: **May 14, 1990**

[52] U.S. Cl. **D8/341; D8/331**

[58] Field of Search **D8/330-346; 70/207-211, 214-217, 225-227, 237-238, 252-253**

D. 312,202	11/1990	Wang	D8/341
4,103,524	9/1978	Mitchell et al.	70/209
4,304,110	1/1981	Fain	70/209
4,738,127	4/1988	Johnson	70/209
4,856,308	6/1989	Johnson	70/209
4,887,443	8/1989	Wang	70/209

Primary Examiner—Brian N. Vinson
Attorney, Agent, or Firm—Bacon & Thomas

[57] **CLAIM**

The ornamental design for an automobile steering wheel lock, as shown and described.

DESCRIPTION

FIG. 1 is a top, front, and left end perspective view of an automobile steering wheel lock showing my new design;

FIG. 2 is a front elevational view thereof;

FIG. 3 is a rear elevational view thereof;

FIG. 4 is a left end elevational view thereof;

FIG. 5 is a right end elevational view thereof;

FIG. 6 is a top plan view thereof; and,

FIG. 7 is a bottom plan view thereof.

[56] **References Cited**

U.S. PATENT DOCUMENTS

D. 289,491	4/1987	Johnson	D8/330
D. 306,252	2/1990	Johnson	D8/330

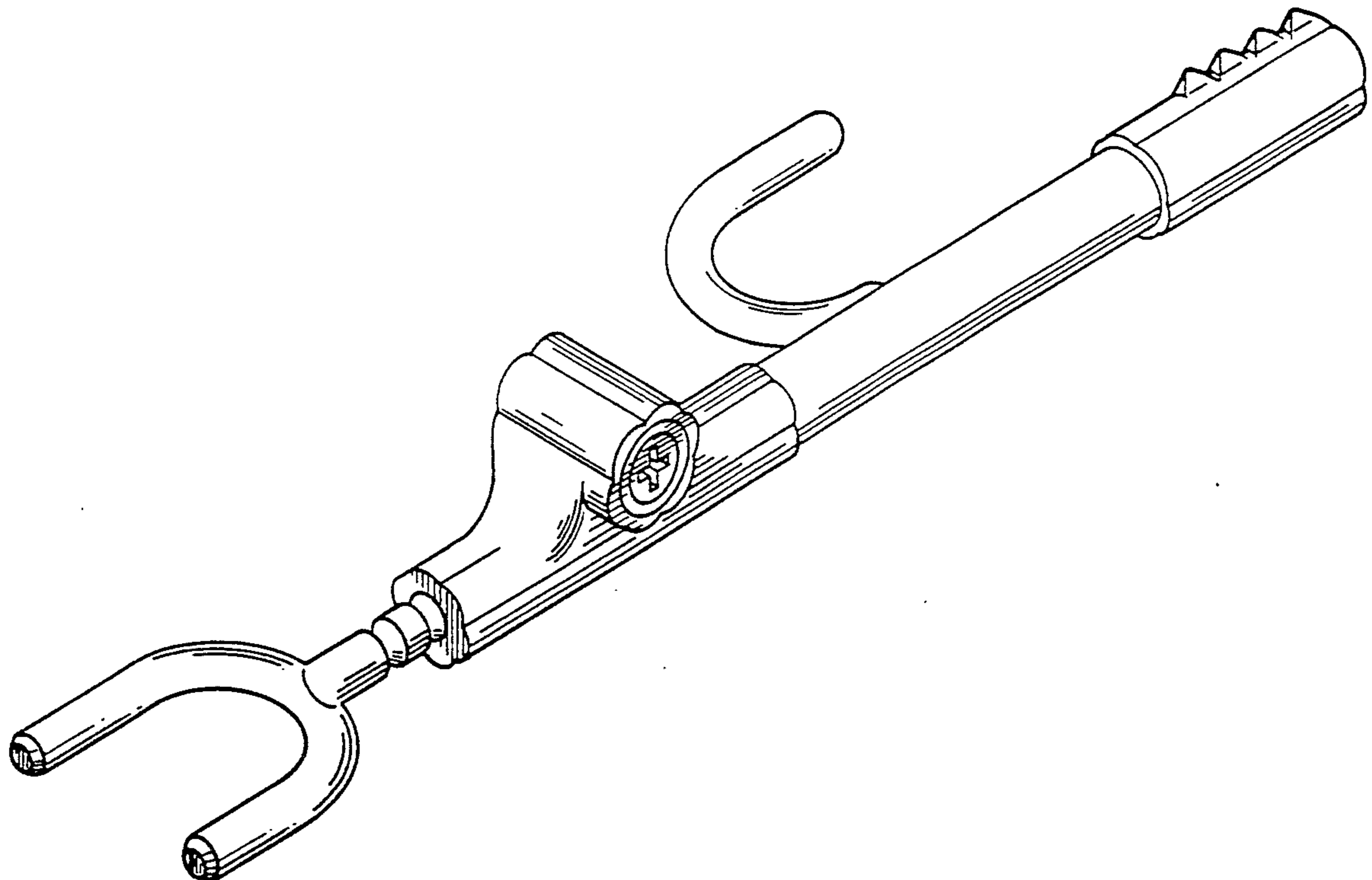

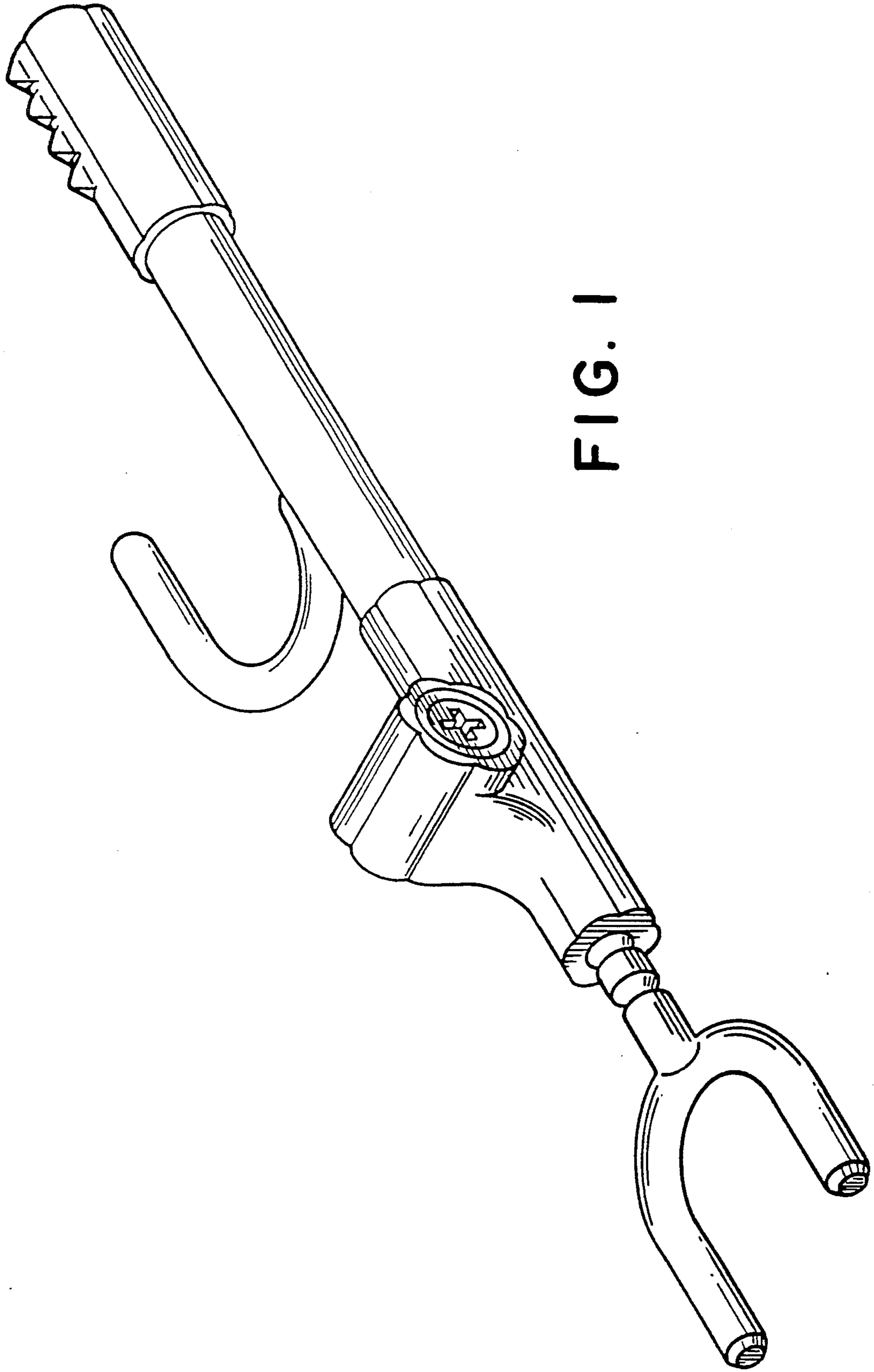

FIG. 1

FIG. 2

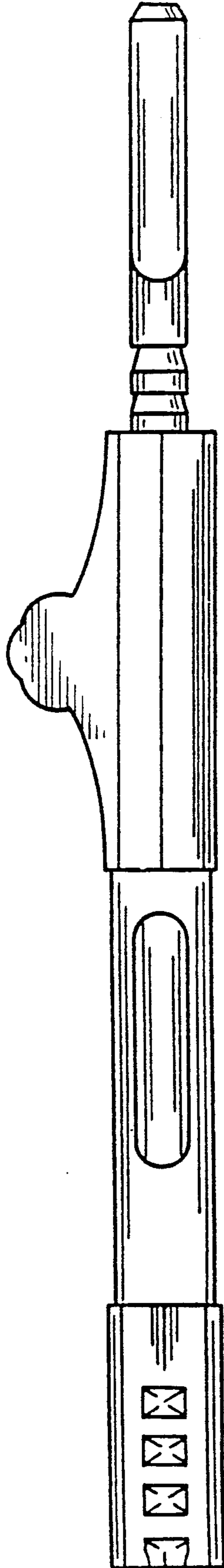
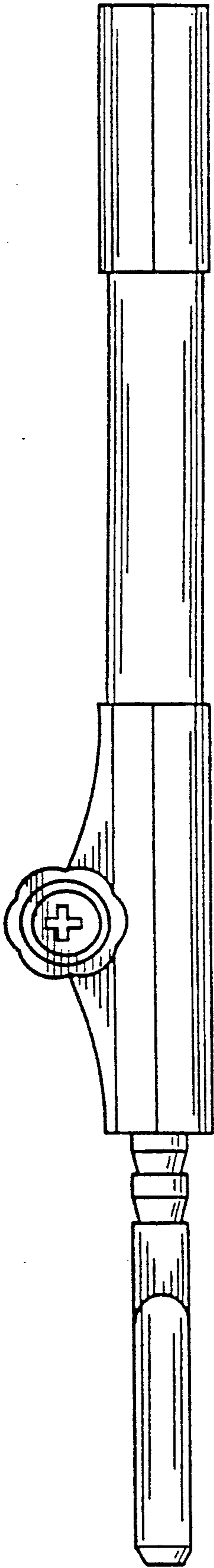

FIG. 3

FIG. 4

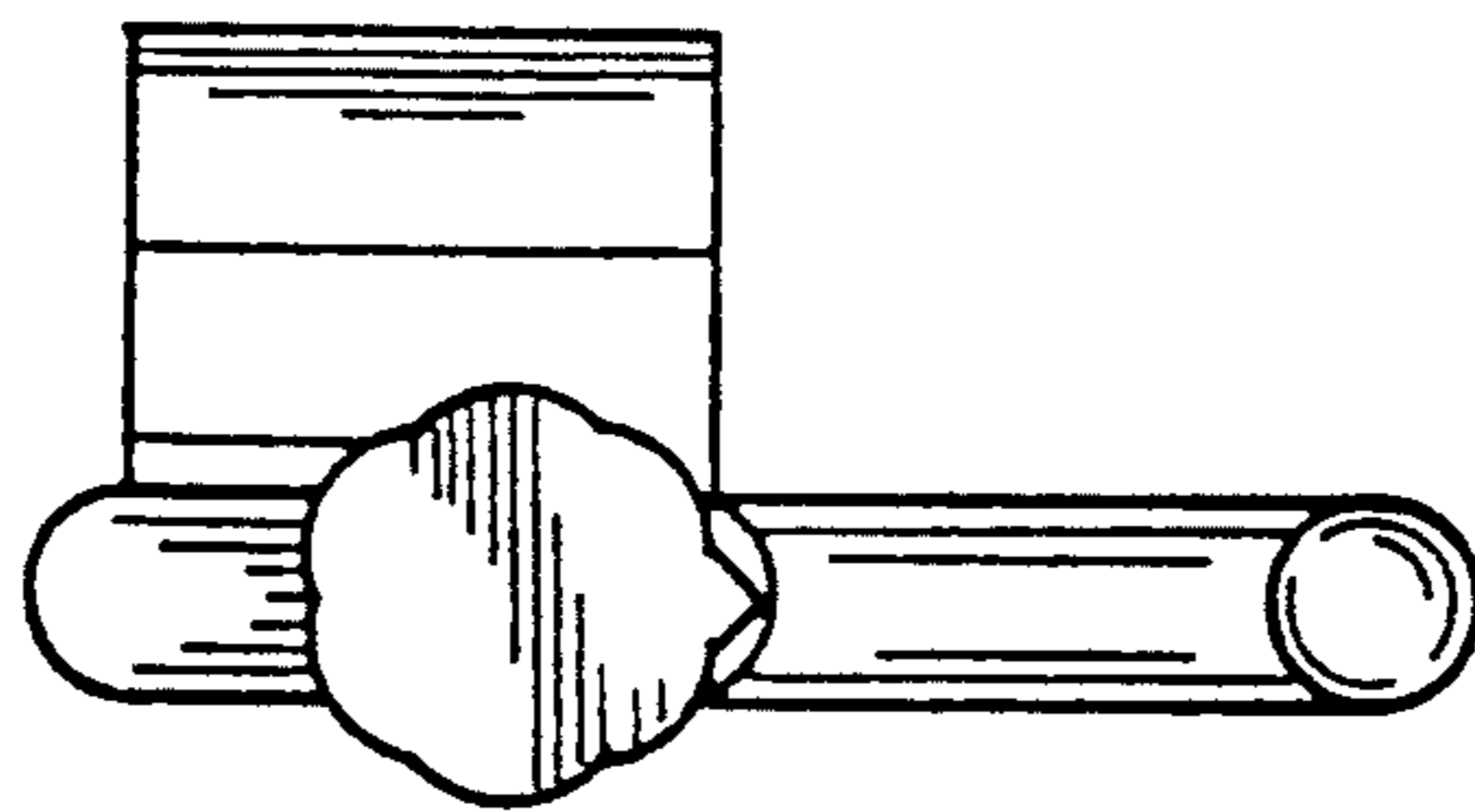
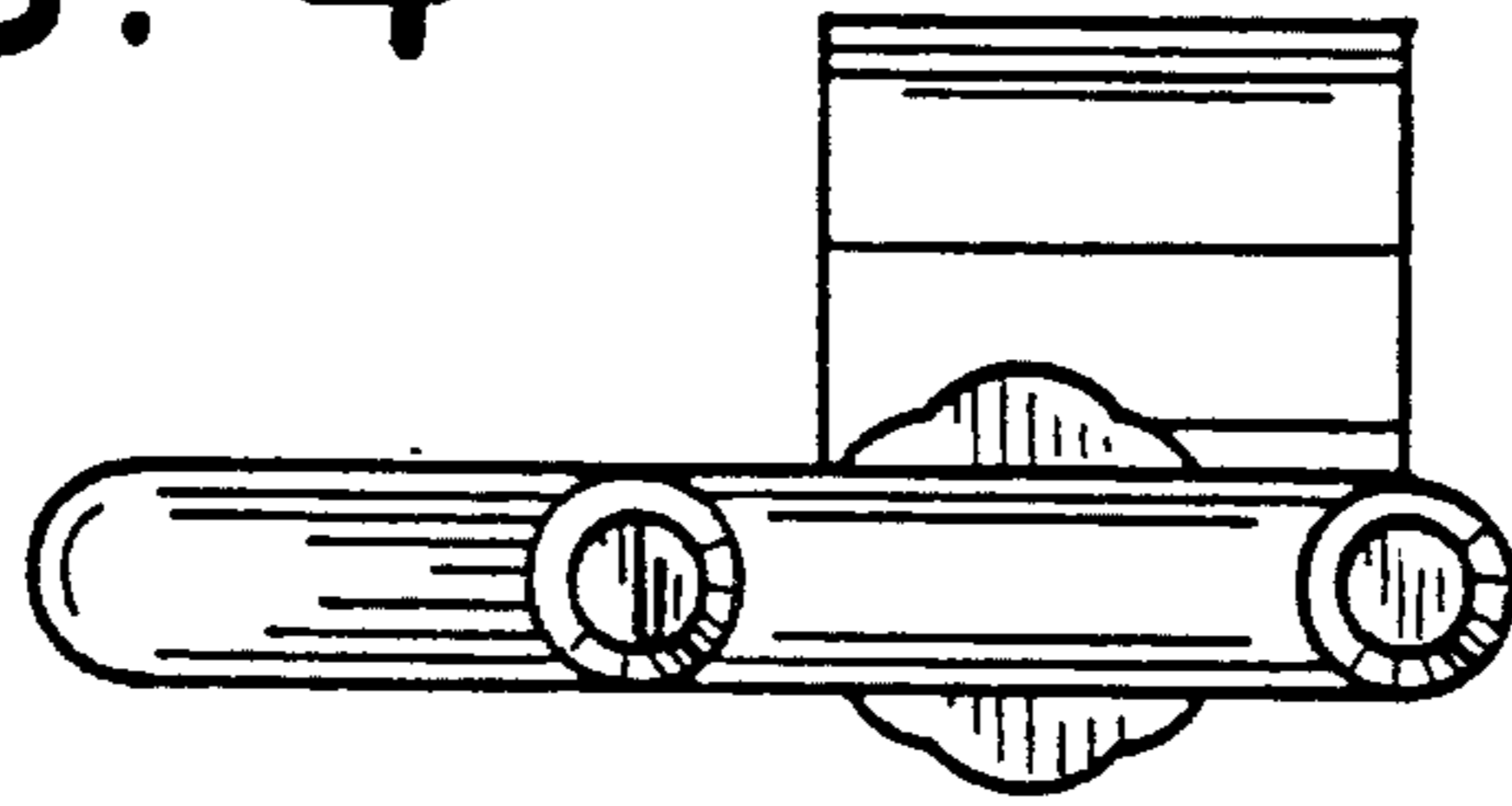

FIG. 5

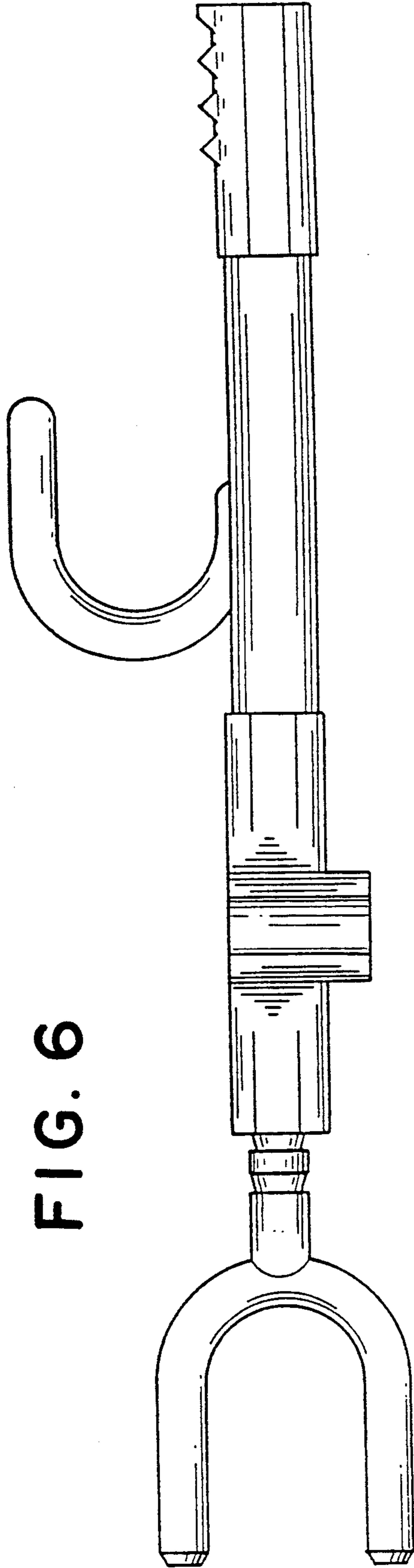

FIG. 6

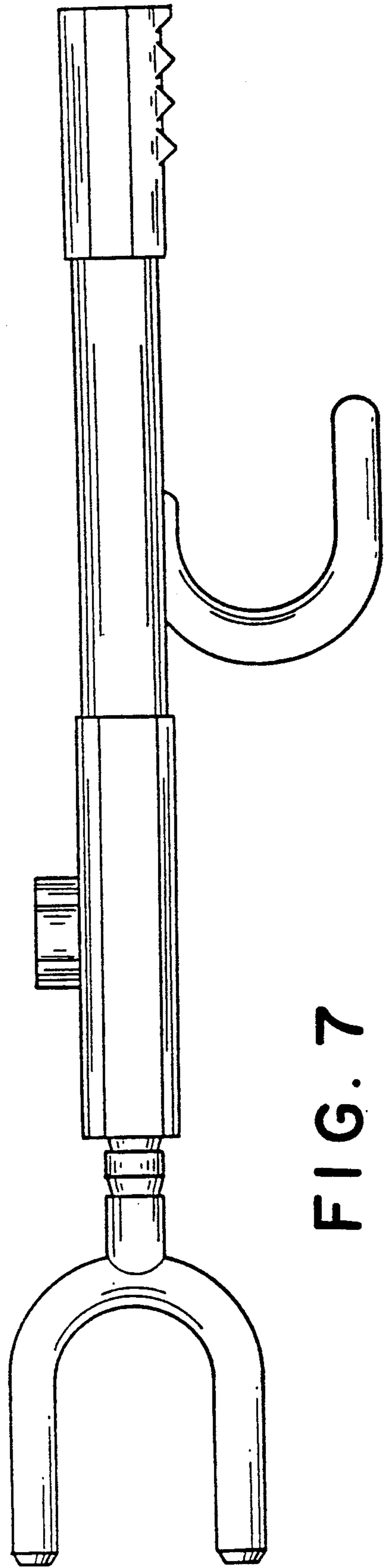

FIG. 7