



US00D327864S

United States Patent [19]

[11] Patent Number: **Des. 327,864**

Siegel et al.

[45] Date of Patent: **** Jul. 14, 1992**

[54] **RECREATIONAL VEHICLE**

[75] Inventors: **Harvey R. Siegel; Rees Noren**, both of Elkhart; **Gene Stout**, Middlebury, all of Ind.

[73] Assignee: **Coachmen Industries, Inc.**, Elkhart, Ind.

[**] Term: **14 Years**

[21] Appl. No.: **559,552**

[22] Filed: **Jul. 23, 1990**

[52] U.S. Cl. **D12/100; D12/99**

[58] Field of Search **D12/99, 100; 296/156, 296/164, 183**

[56] **References Cited**

U.S. PATENT DOCUMENTS

D. 227,757 7/1973 Thoresen D12/100

OTHER PUBLICATIONS

R. V. Business, May 19, 1989, Amerigo Van, top right side of page.

R. V. Business, Jul. 17, 1989, p. 62, Van, lower left side of page.

R. V. Business, Nov. 14, 1988, p. 8, Sterling Motor Home, lower left side of page.

Primary Examiner—James M. Gandy
Attorney, Agent, or Firm—James D. Hall

[57] **CLAIM**

The ornamental design for a recreational vehicle, as shown and described.

DESCRIPTION

FIG. 1 is a perspective view of the recreational vehicle showing our new design;

FIG. 2 is a right side elevational view thereof;

FIG. 3 is a top plan view thereof;

FIG. 4 is a front end elevational view thereof;

FIG. 5 is a rear end elevational view thereof; and,

FIG. 6 is a left side elevational view thereof.

FIG. 7 is a perspective view of the recreational vehicle showing a second embodiment of our new design;

FIG. 8 is a right side elevational view of the second embodiment;

FIG. 9 is a top plan view of the second embodiment;

FIG. 10 is a rear end elevational view of the second embodiment; and,

FIG. 11 is a left side elevational view of the second embodiment.

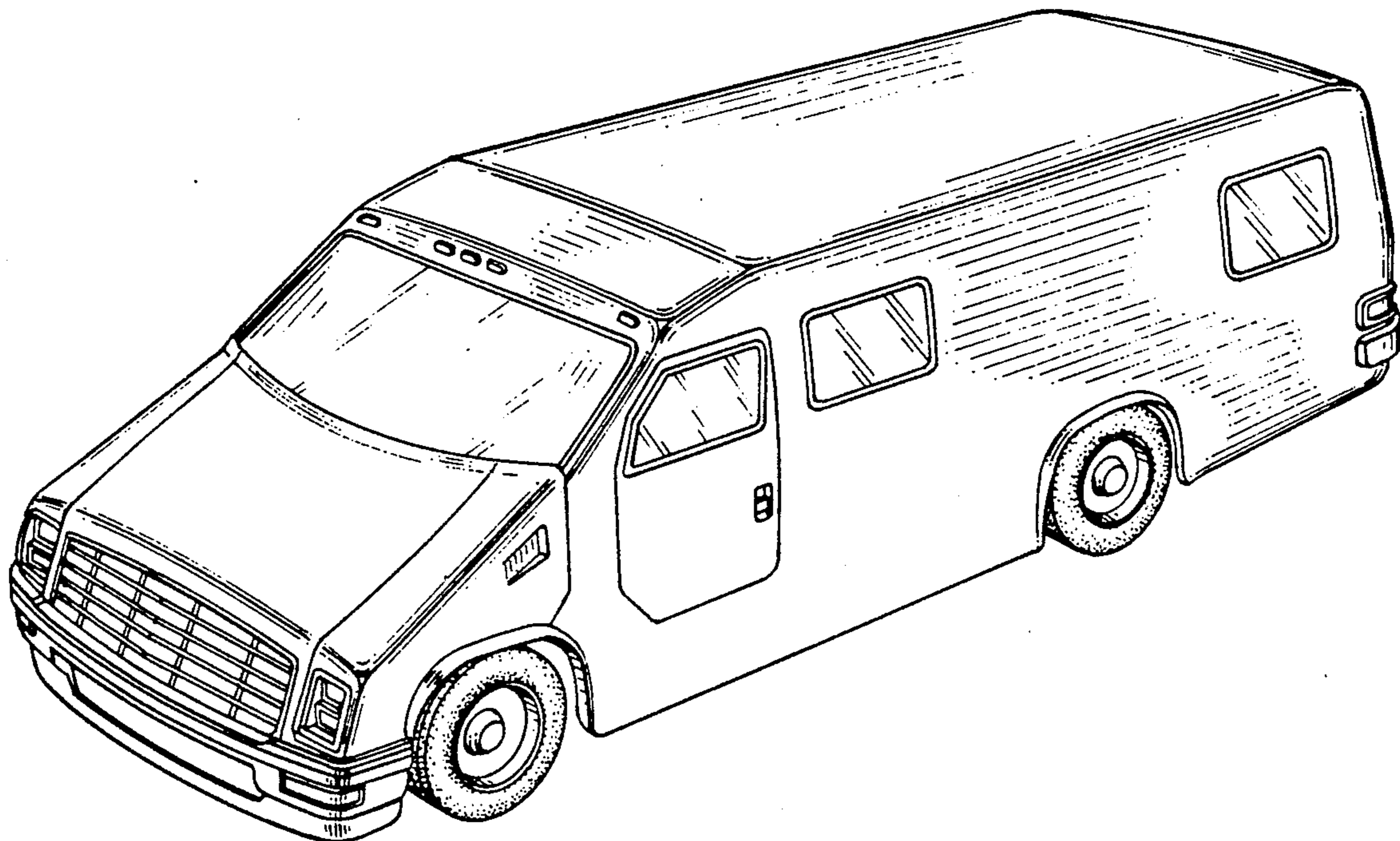

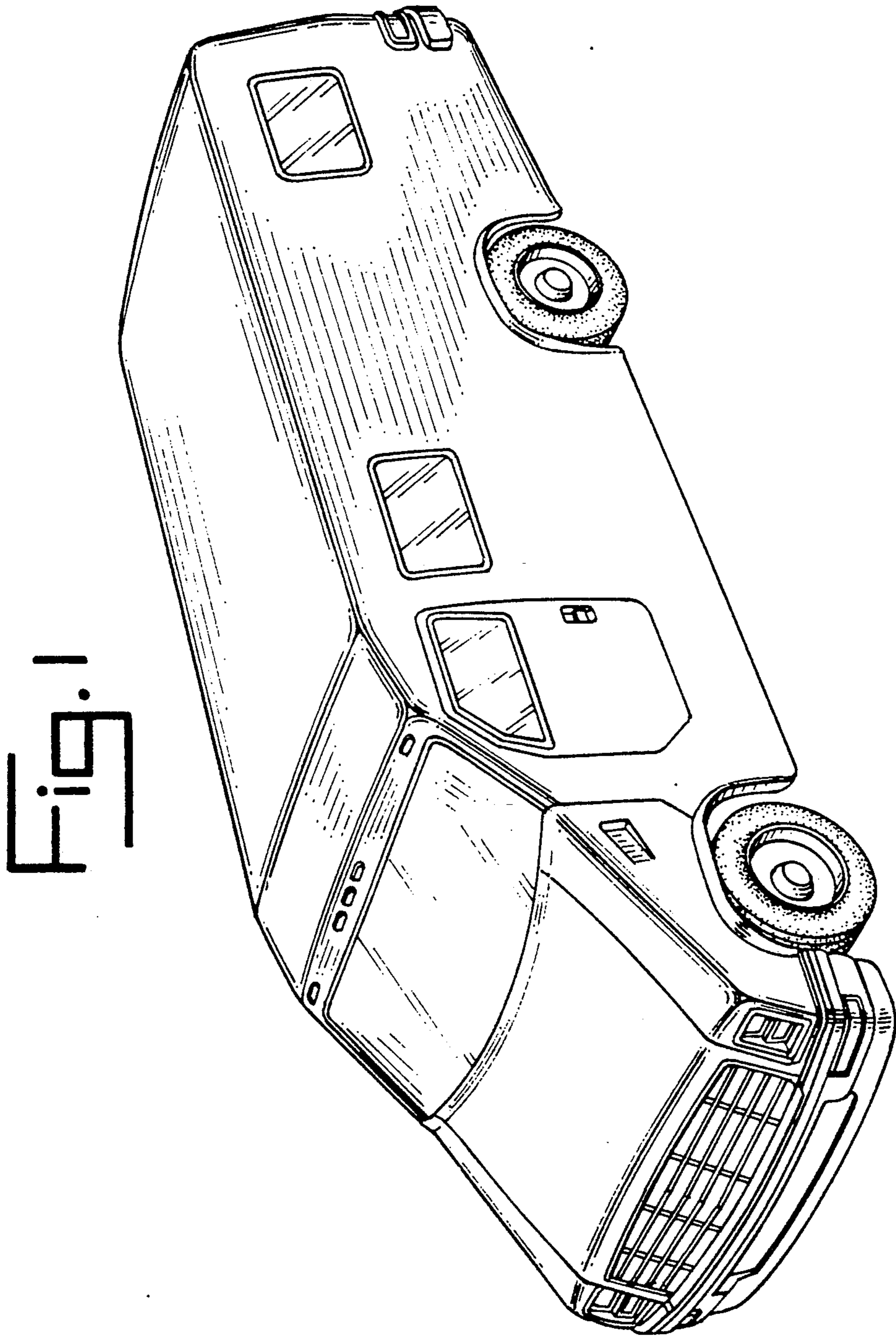

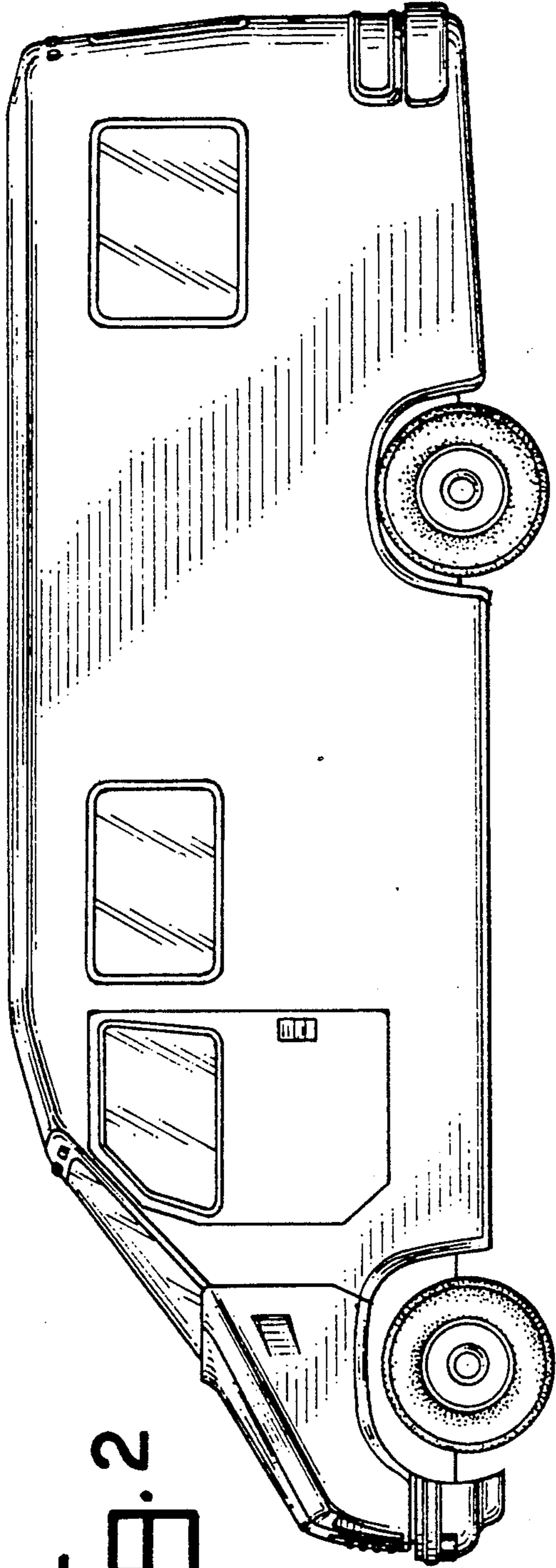

FIG. 2

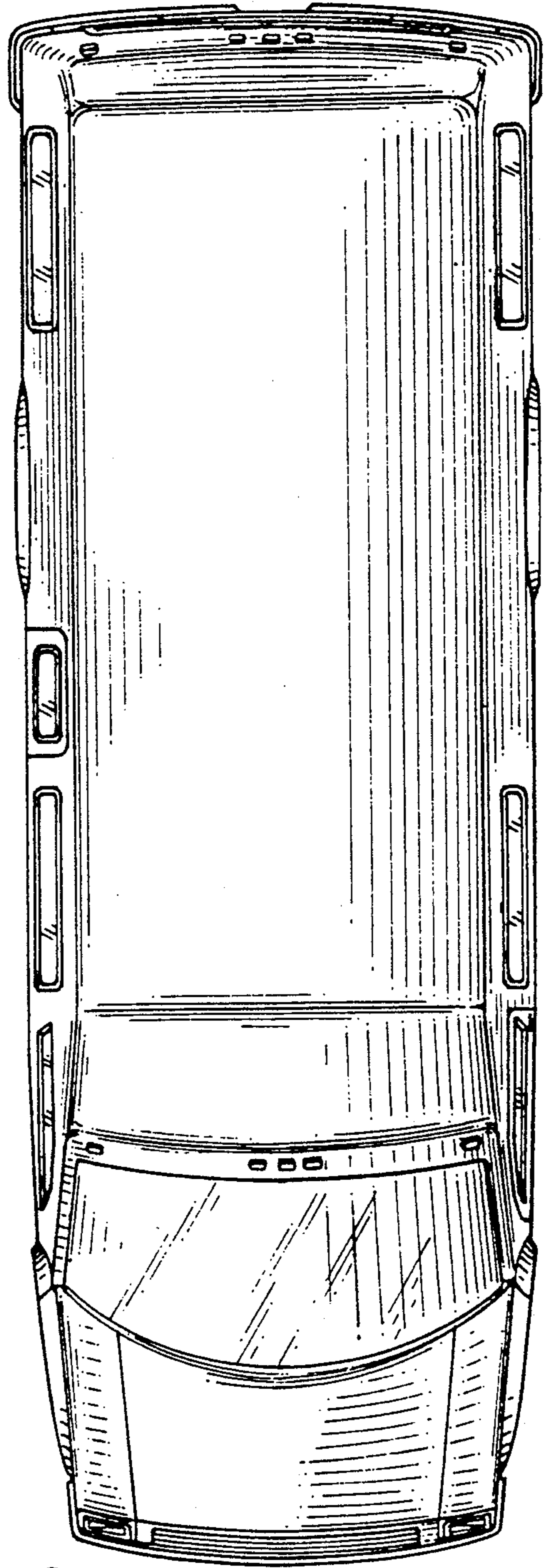

FIG. 3

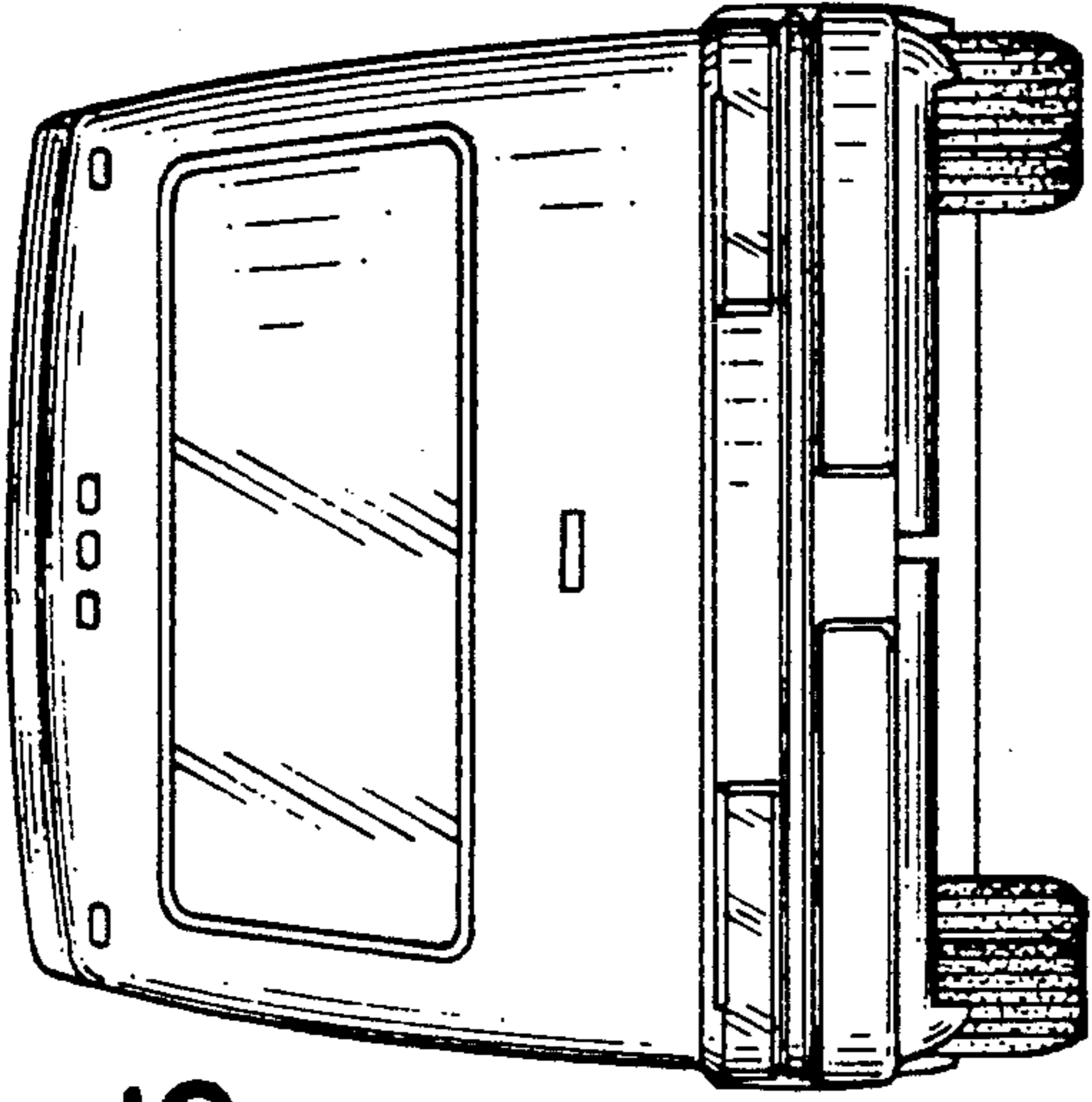

Fig. 5

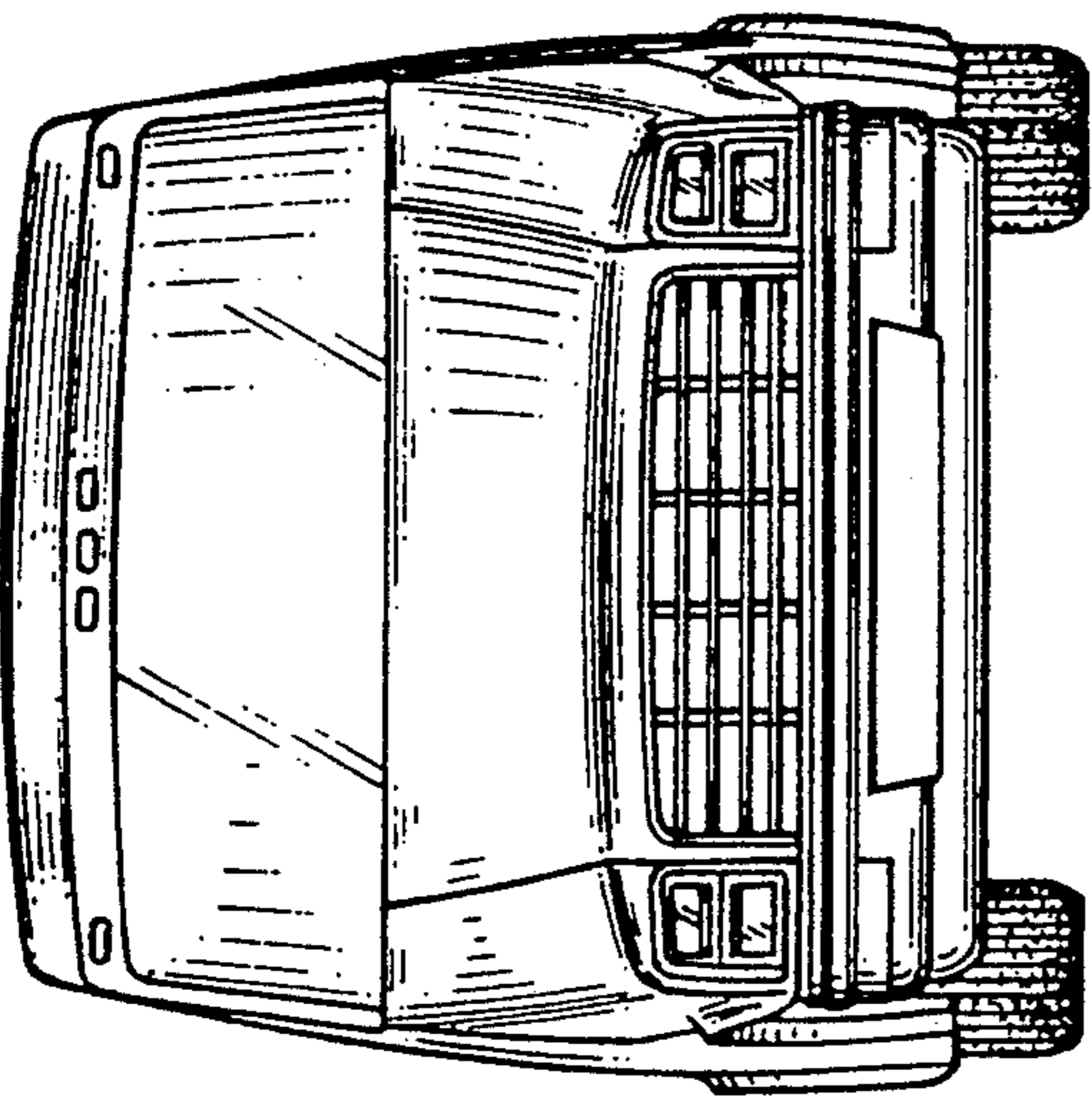

Fig. 4

Fig. 6

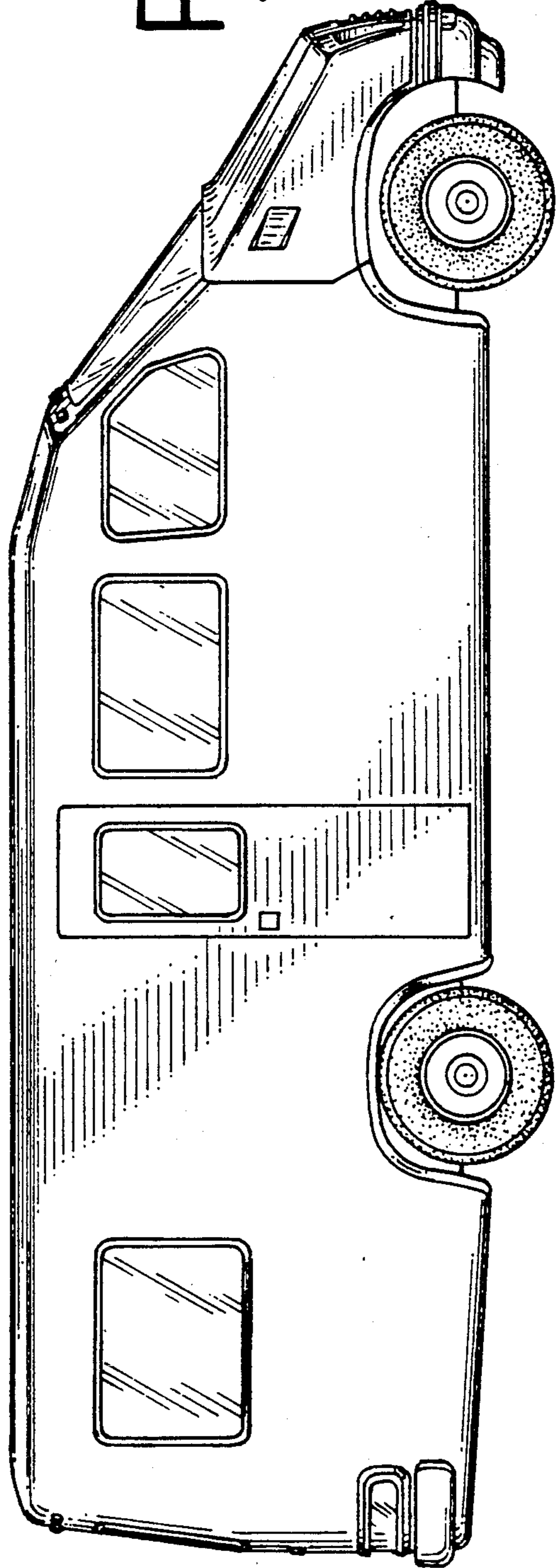
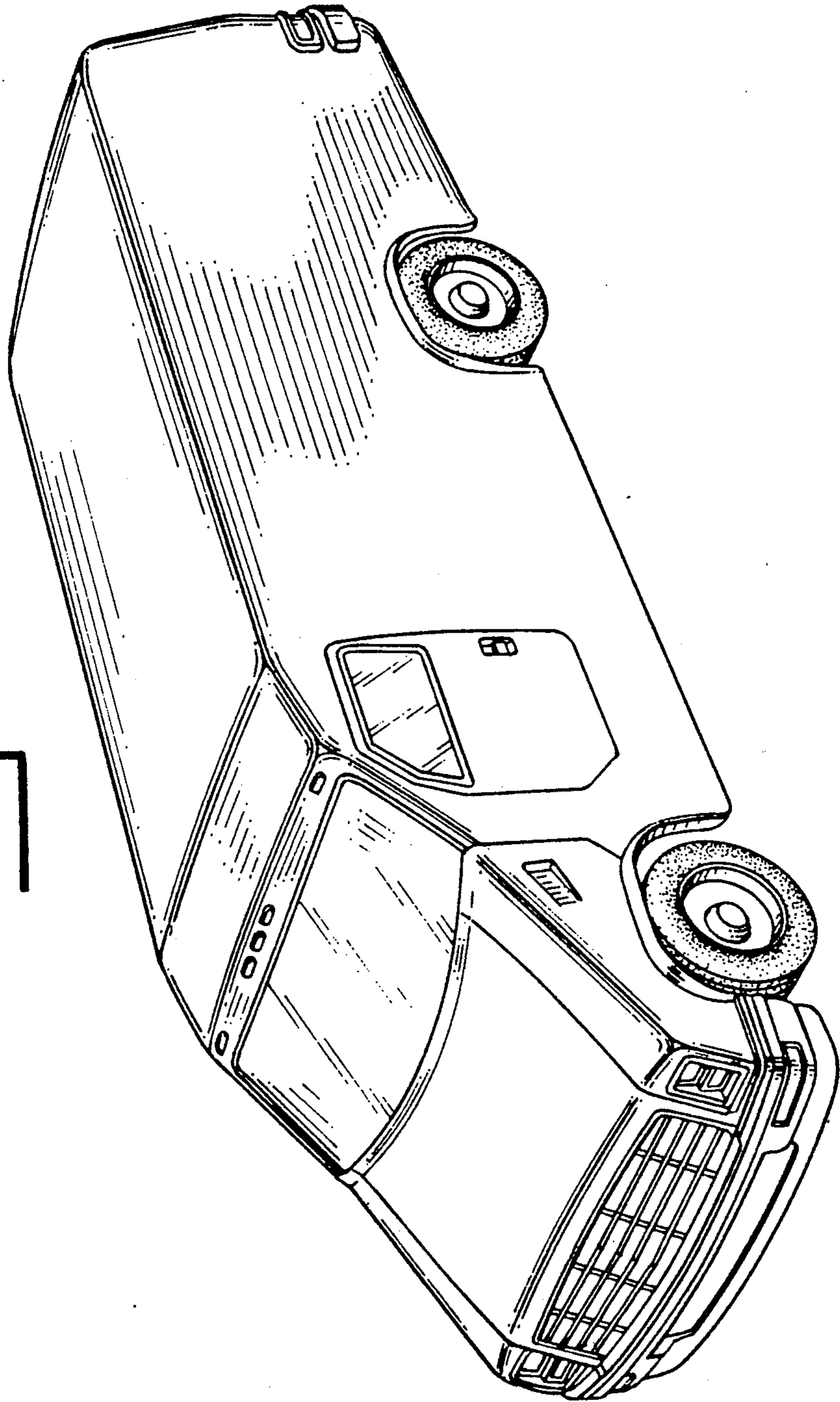

Fig. 7



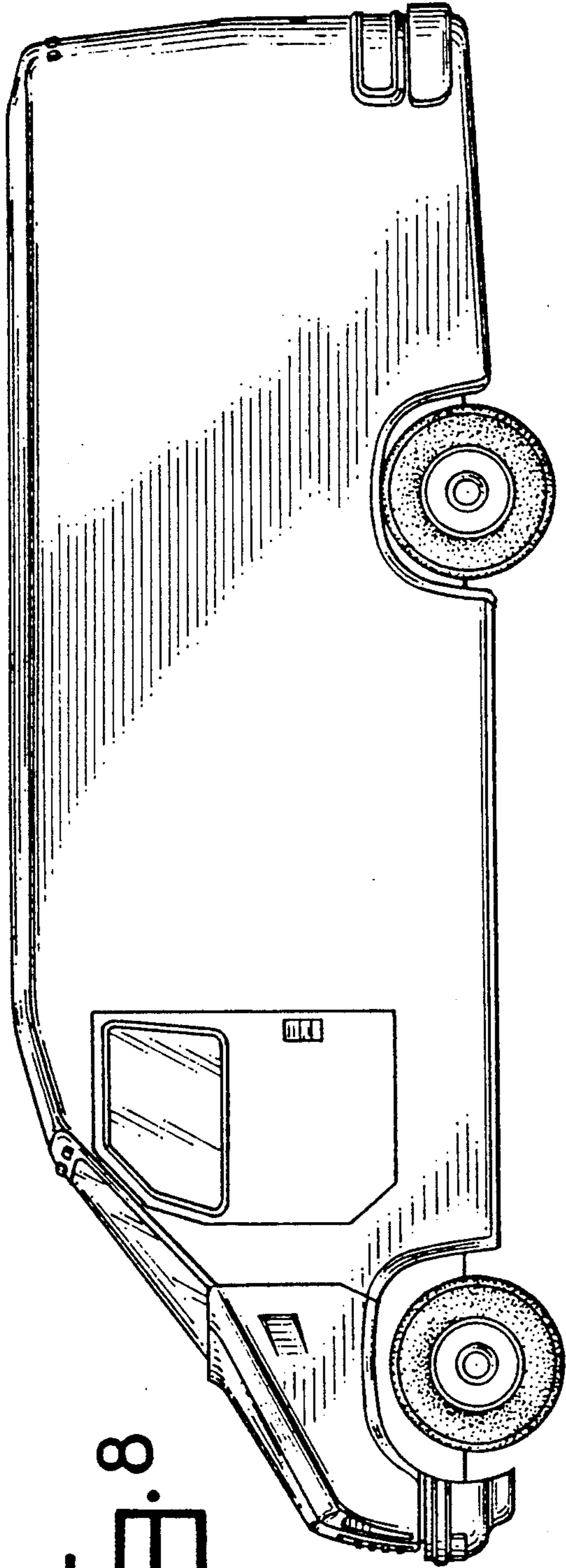

Fig. 8

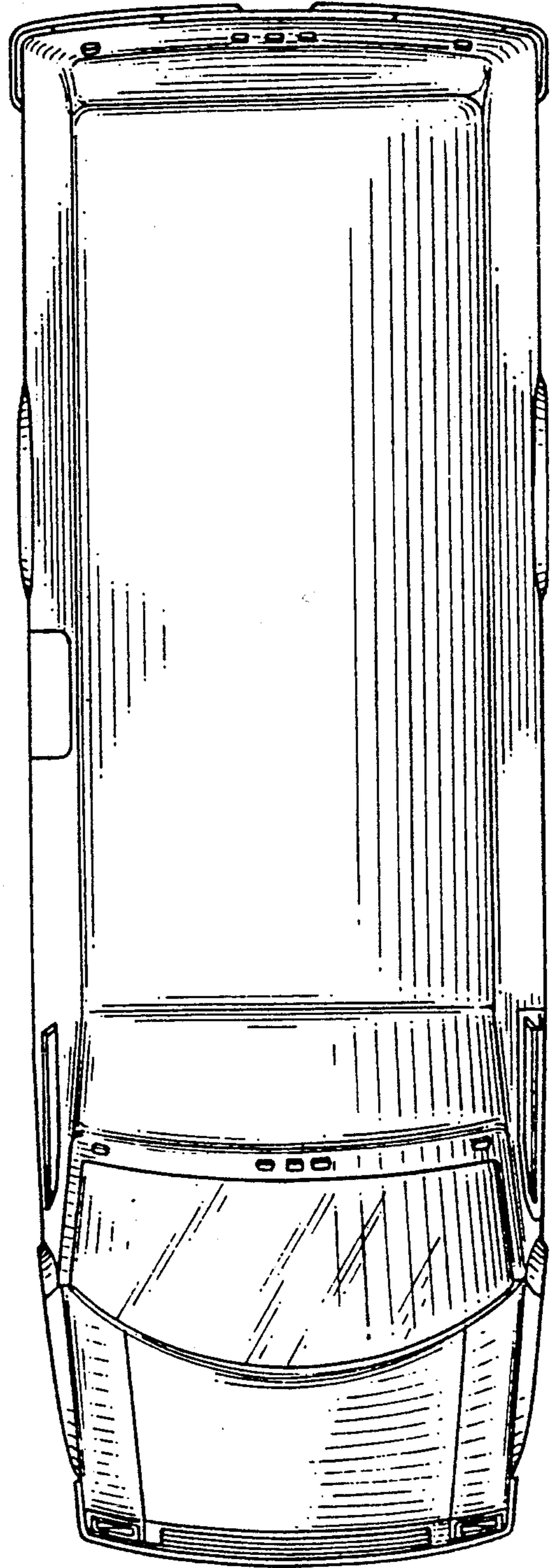

Fig. 9

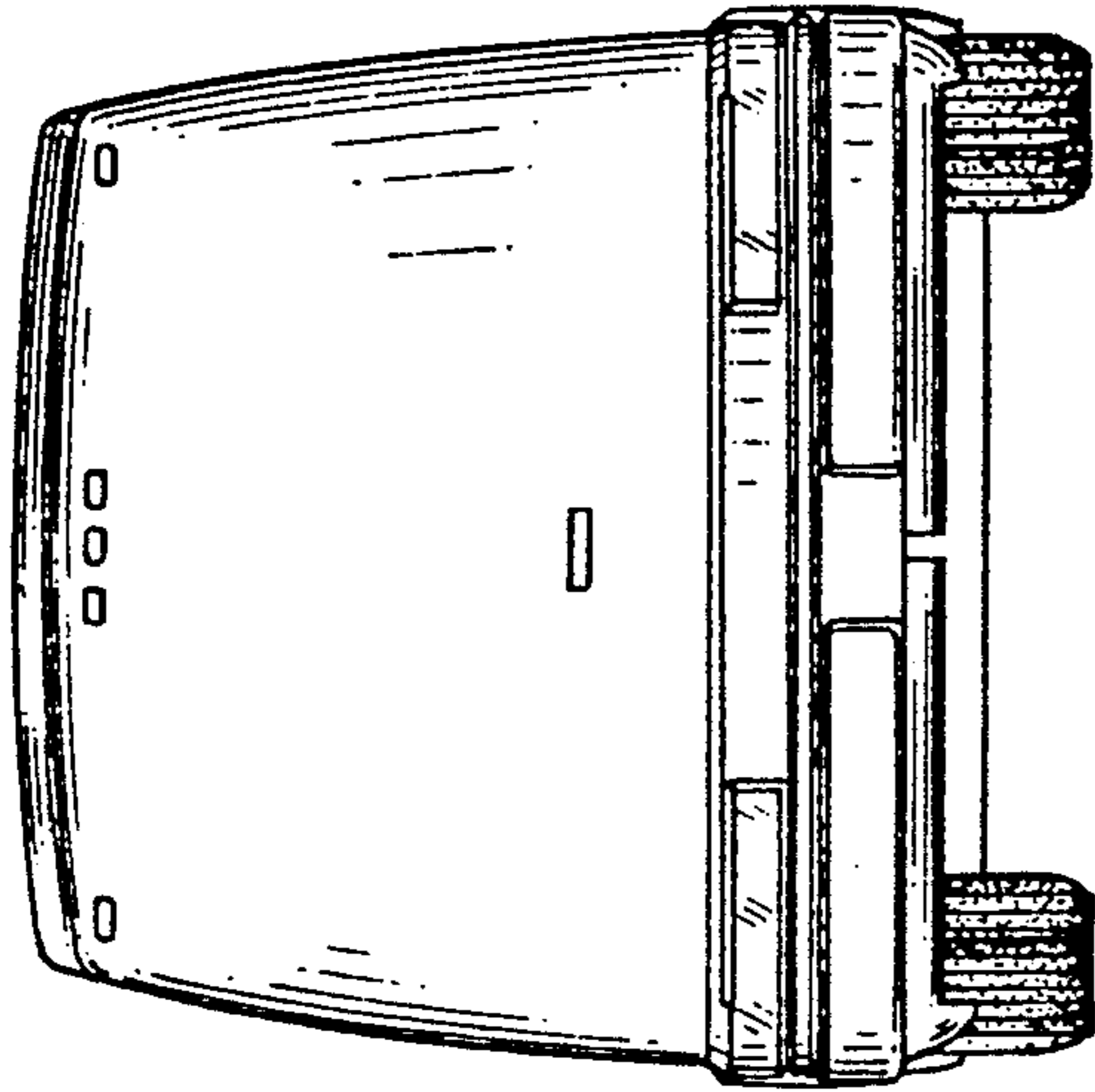

FIG. 10

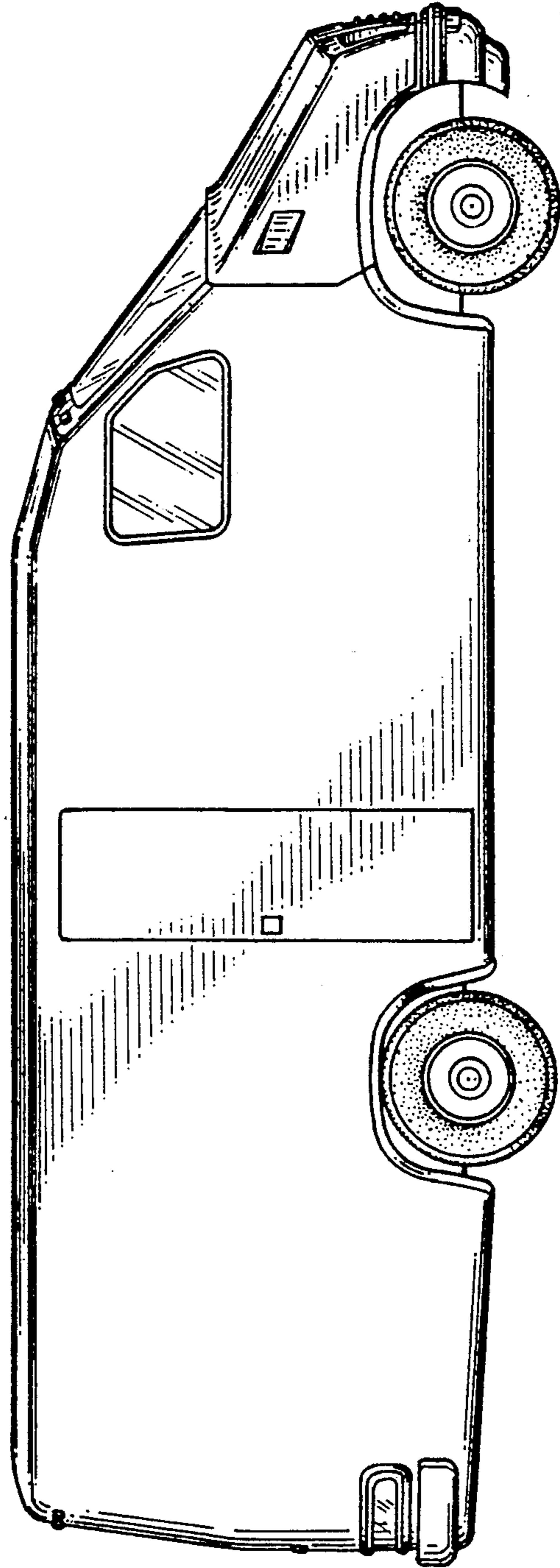

FIG. 11