



US00D327796S

United States Patent [19]
Ryaa

[11] **Patent Number: Des. 327,796**
[45] **Date of Patent: ** Jul. 14, 1992**

[54] **SEAT**
[75] **Inventor: Jan Ryaa, Billund, Denmark**
[73] **Assignee: Interlego A.G., Baar, Switzerland**
[**] **Term: 14 Years**
[21] **Appl. No.: 365,513**
[22] **Filed: Jun. 13, 1989**

[30] **Foreign Application Priority Data**
Dec. 23, 1988 [DK] Denmark 1528/1988
[52] **U.S. Cl. D6/500; D6/337;
D6/362; D6/484**
[58] **Field of Search D6/334, 340, 349, 354,
D6/362, 484, 500, 501, 502; 297/157, 170, 172,
174**

[56] **References Cited**
U.S. PATENT DOCUMENTS
D. 97,846 12/1935 Ely D6/349
D. 139,702 12/1944 Castle D6/349

D. 237,917 12/1975 Seymour D6/362 X
D. 239,482 4/1976 Sparrow et al. D6/349
D. 285,150 8/1986 Ikegami D6/364
4,526,422 7/1985 Mengshoel et al. 297/243

Primary Examiner—Donald P. Walsh
Assistant Examiner—Gary D. Watson
Attorney, Agent, or Firm—Kane, Dalsimer, Sullivan,
Kurucz, Levy, Eisele and Richard

[57] **CLAIM**

The ornamental design for a seat, as shown and described.

DESCRIPTION

FIG. 1 is a top, front, left side perspective view of a seat showing my new design;
FIG. 2 is a bottom, rear, right side perspective view;
FIG. 3 is a right side elevational view, the left side being a mirror image thereof;
FIG. 4 is a front elevational view;
FIG. 5 is a rear elevational view;
FIG. 6 is a top plan view; and,
FIG. 7 is a bottom plan view thereof.

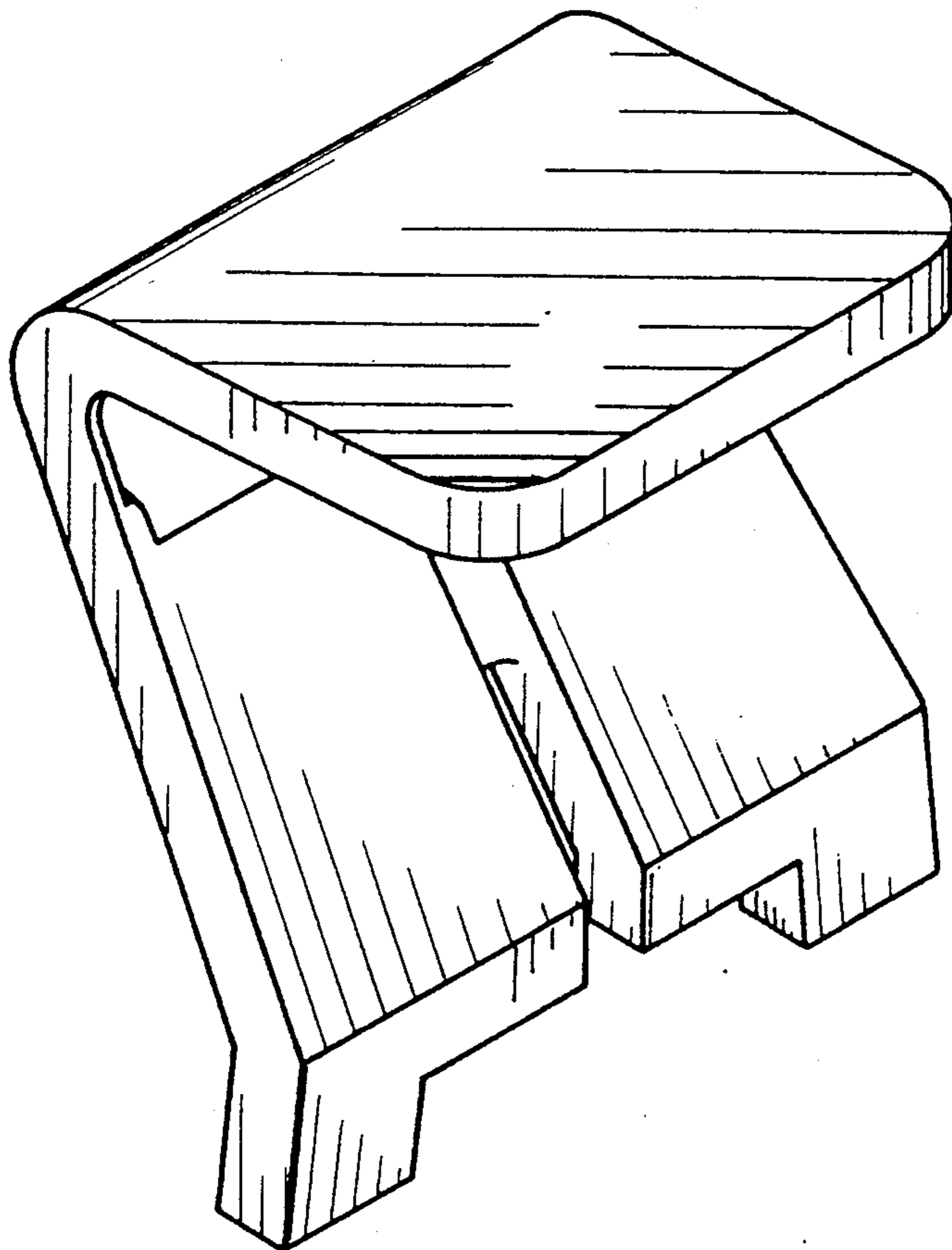

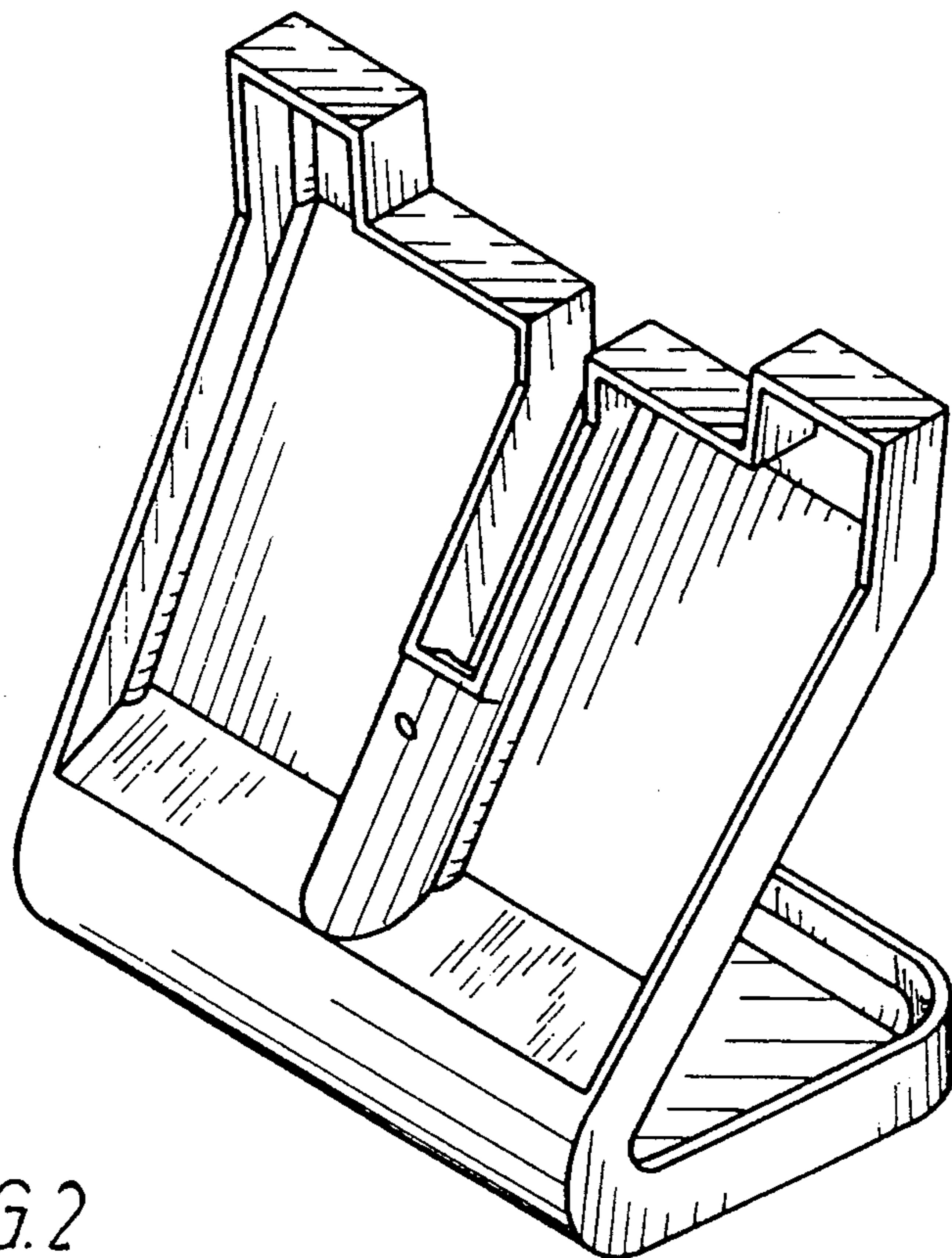
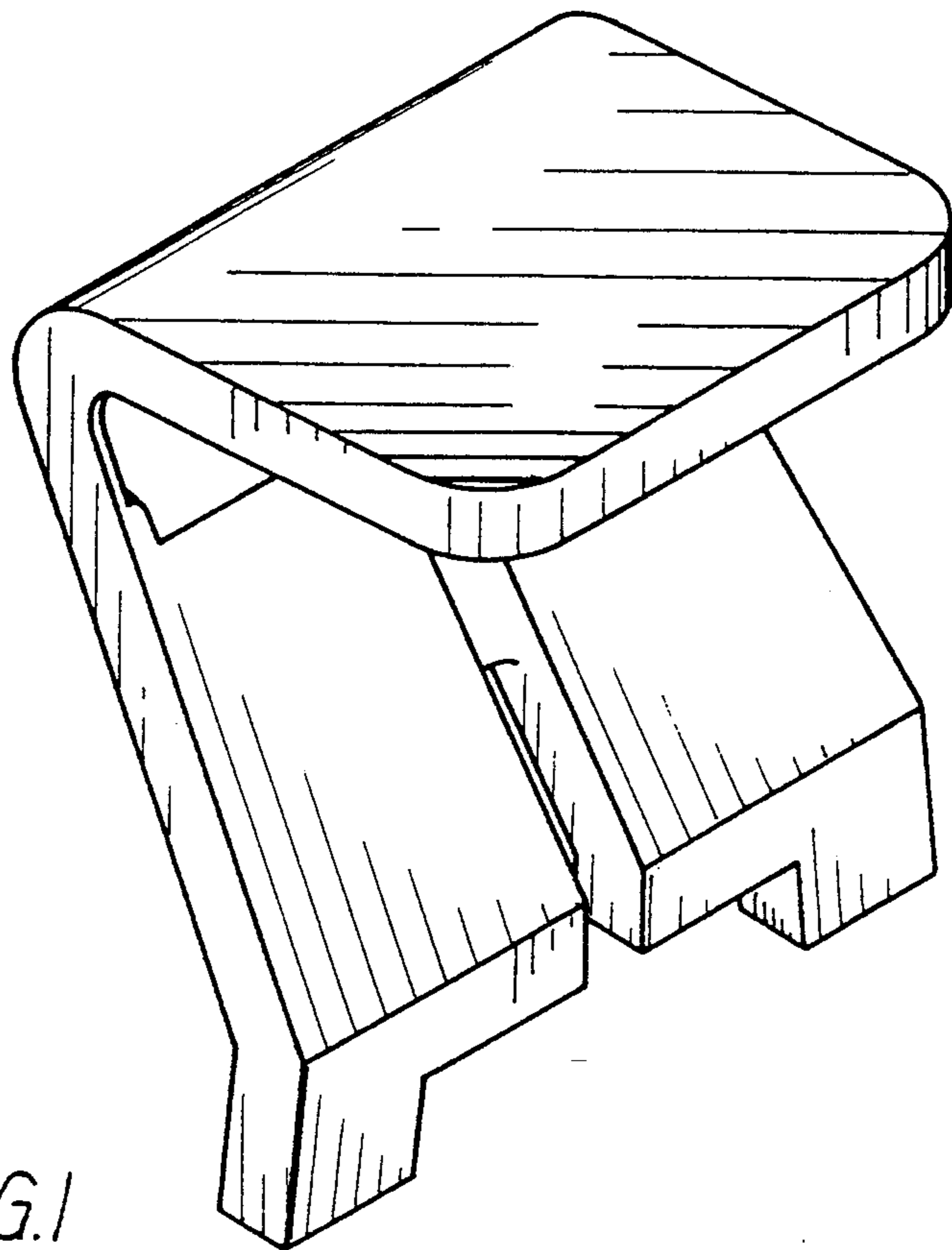

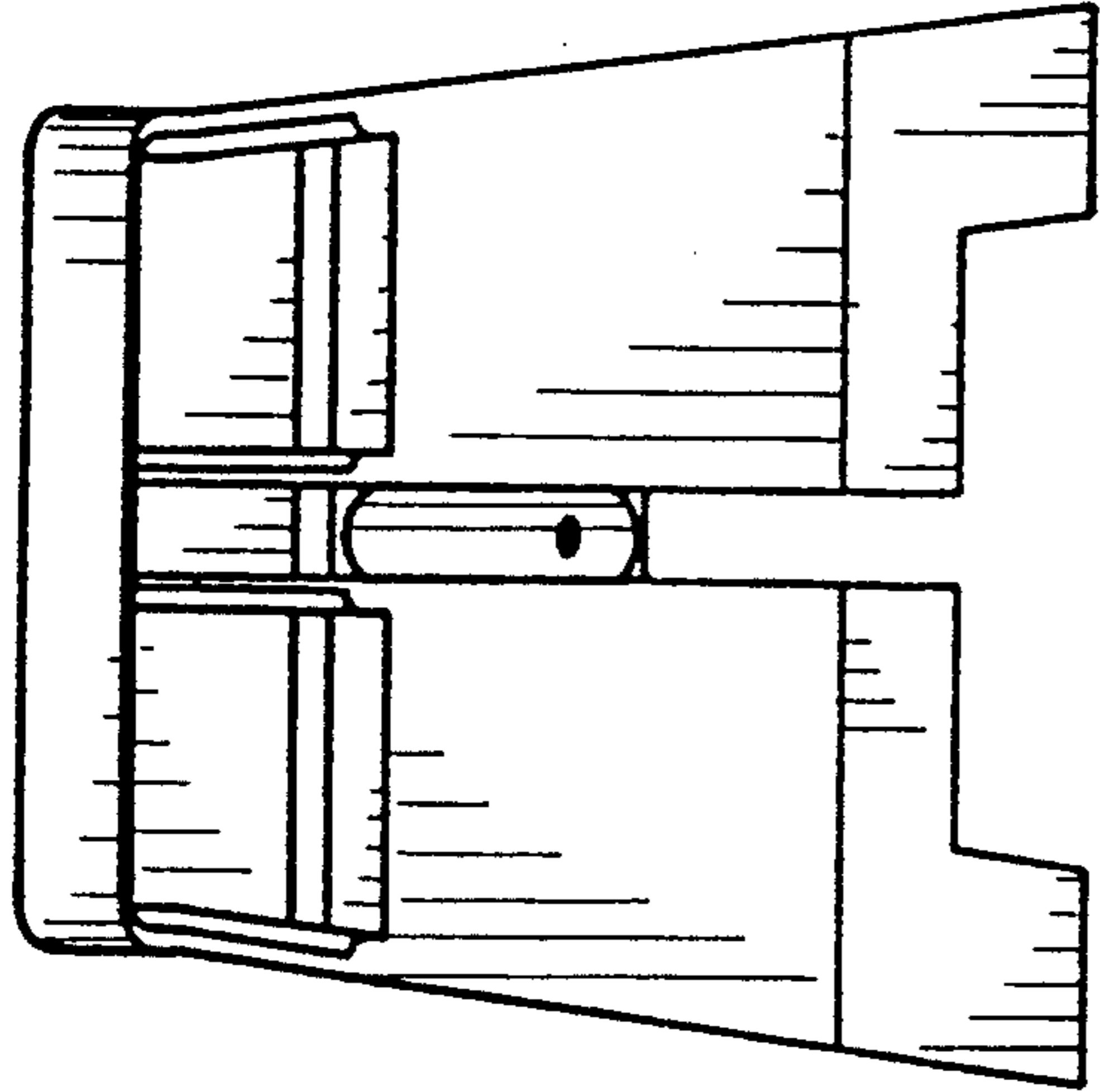

FIG. 3

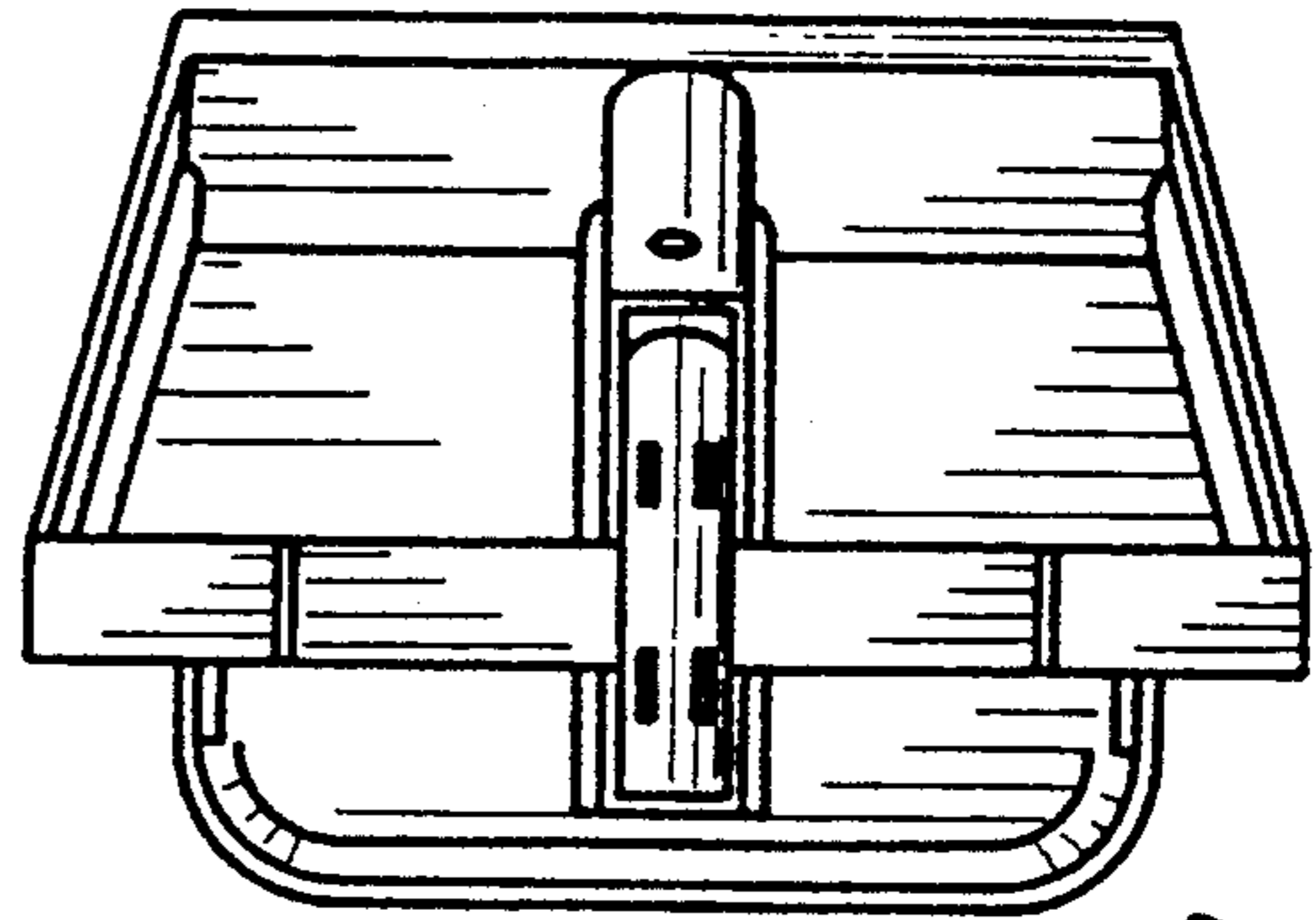

FIG. 7

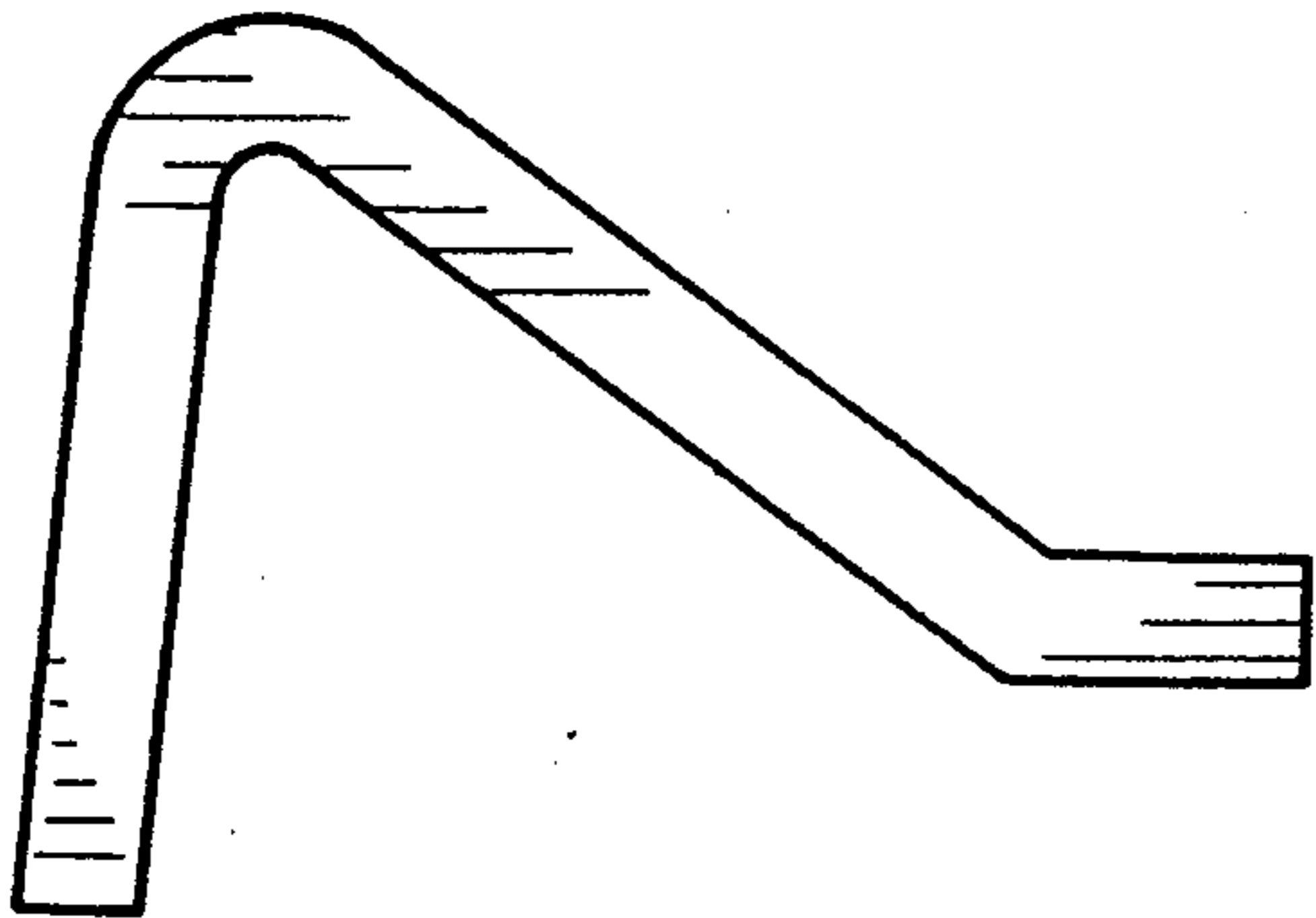

FIG. 4

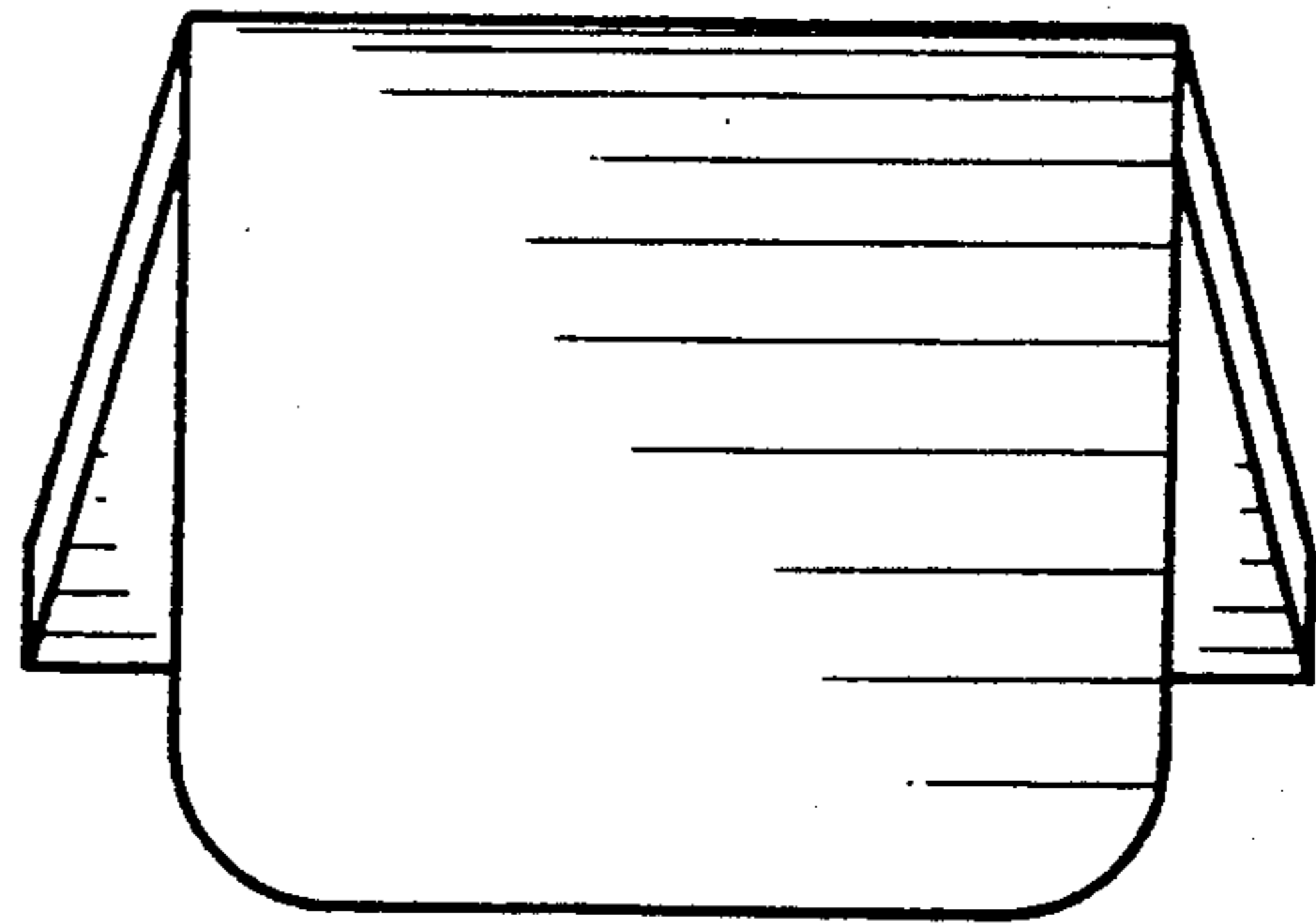

FIG. 6

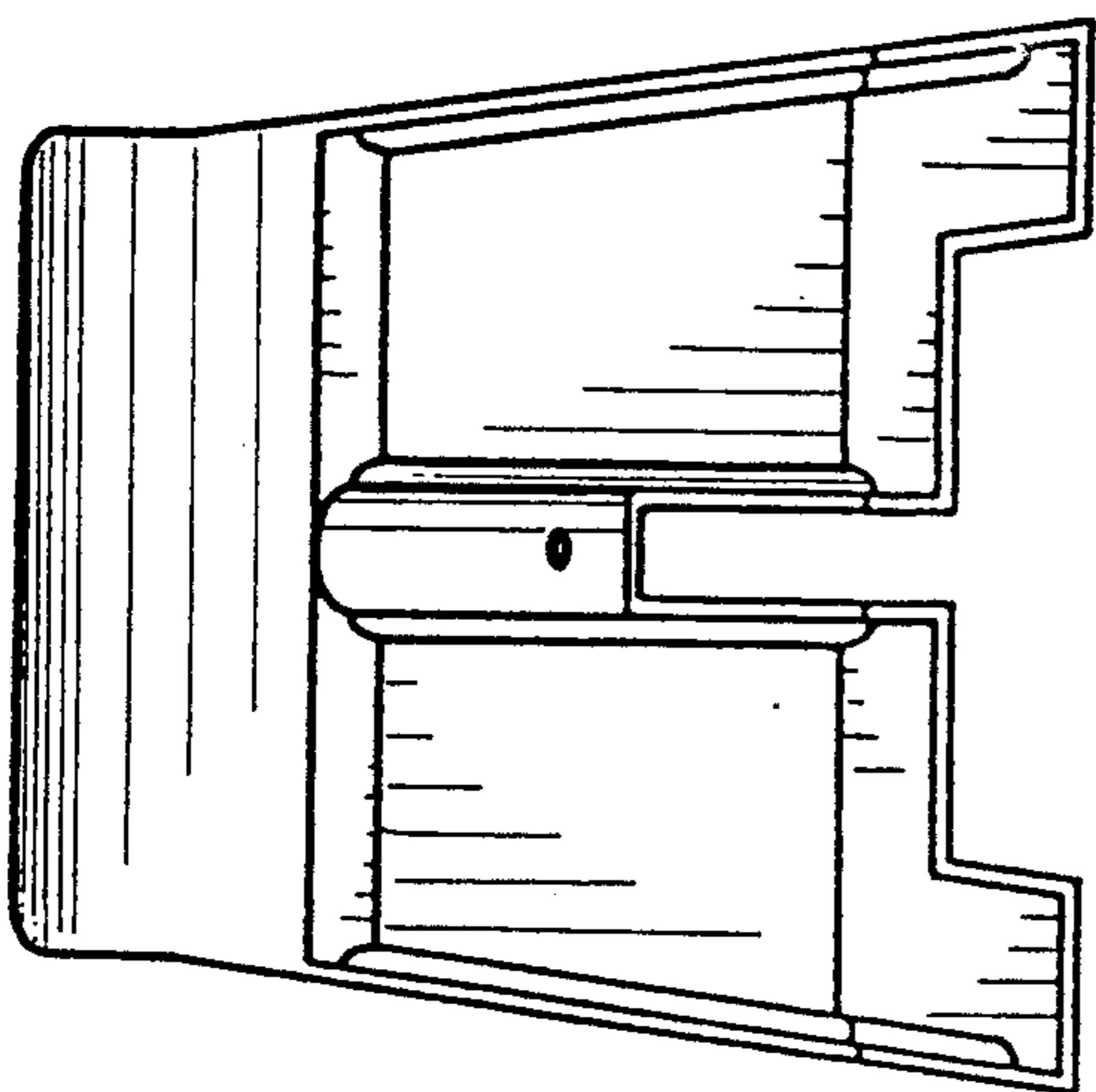

FIG. 5