



US00D327773S

United States Patent [19]

[11] Patent Number: **Des. 327,773**

Ang

[45] Date of Patent: **** Jul. 14, 1992**

[54] CARRIER FOR SKIS AND SKI POLES

4,620,722	11/1986	Dunn	280/814
4,883,290	11/1989	Landa	224/917
5,013,066	5/1991	Adkins	280/809

[76] Inventor: **John Ang**, 310 Marek Dr.,
Montebello, Calif. 90640

Primary Examiner—Kay H. Chin
Attorney, Agent, or Firm—G. Donald Weber, Jr.

[**] Term: **14 Years**

[21] Appl. No.: **490,270**

[57] **CLAIM**

[22] Filed: **Mar. 8, 1990**

The ornamental design for a carrier for skis and ski poles, as shown and described.

[52] U.S. Cl. **D3/36; D21/229; D34/27**

DESCRIPTION

[58] Field of Search **D34/12, 27, 23; 280/814, 815, 809; D21/229, 230; 224/917, 247, 42.45 R; D3/36**

FIG. 1 is a top and front perspective view of a carrier for skis and ski poles showing my new design; FIG. 2 is a top plan view thereof; FIG. 3 is a front elevational view thereof; FIG. 4 is a side elevational view thereof, the opposite side elevational view being a mirror image of that shown; FIG. 5 is a bottom plan view thereof; and, FIG. 6 is a rear elevational view thereof.

[56] **References Cited**

U.S. PATENT DOCUMENTS

D. 241,781	10/1976	Klawitter	D3/36
D. 288,032	2/1987	Gainey	D3/36
4,274,571	6/1981	Lafreniere et al.	280/814

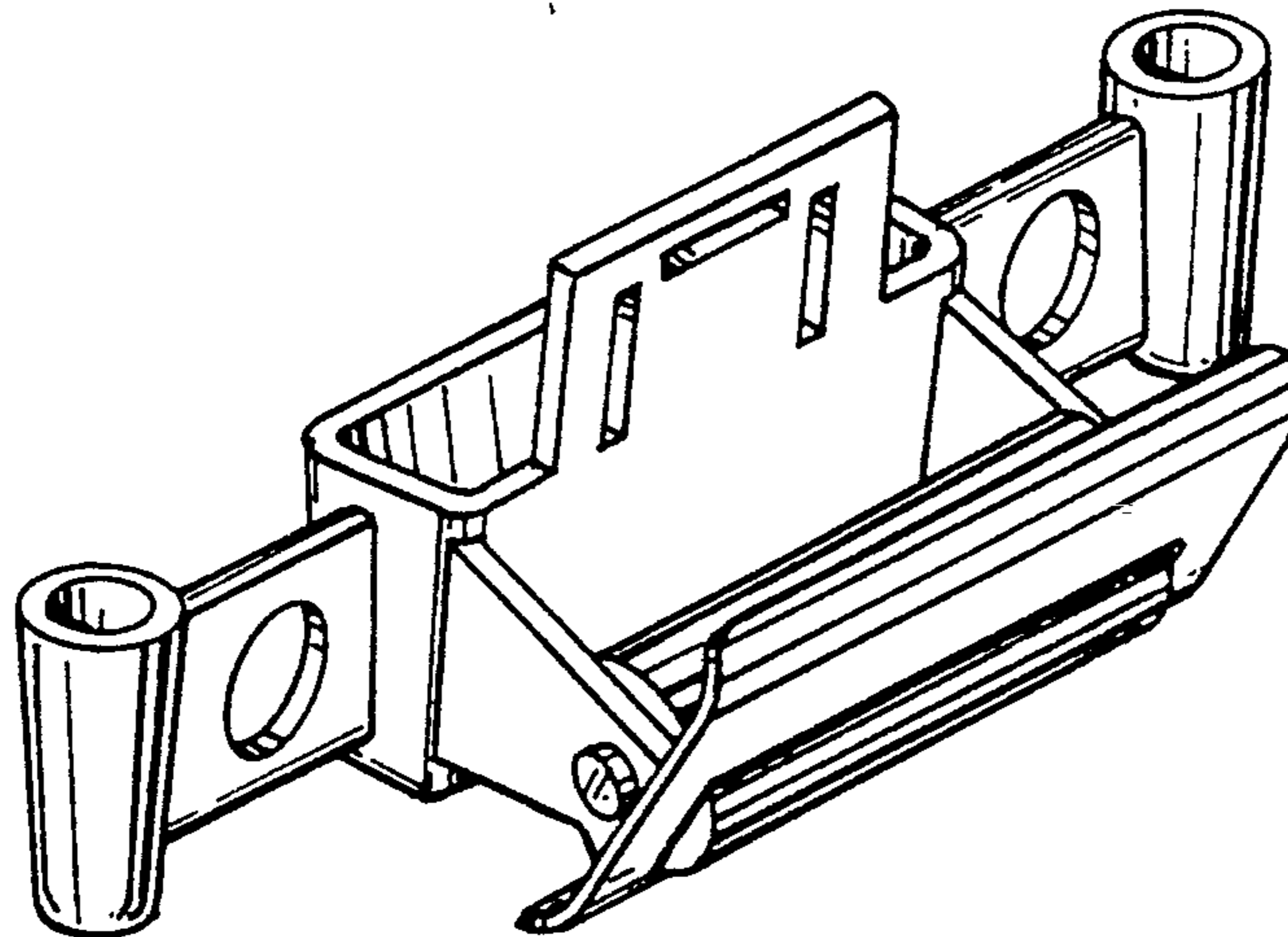

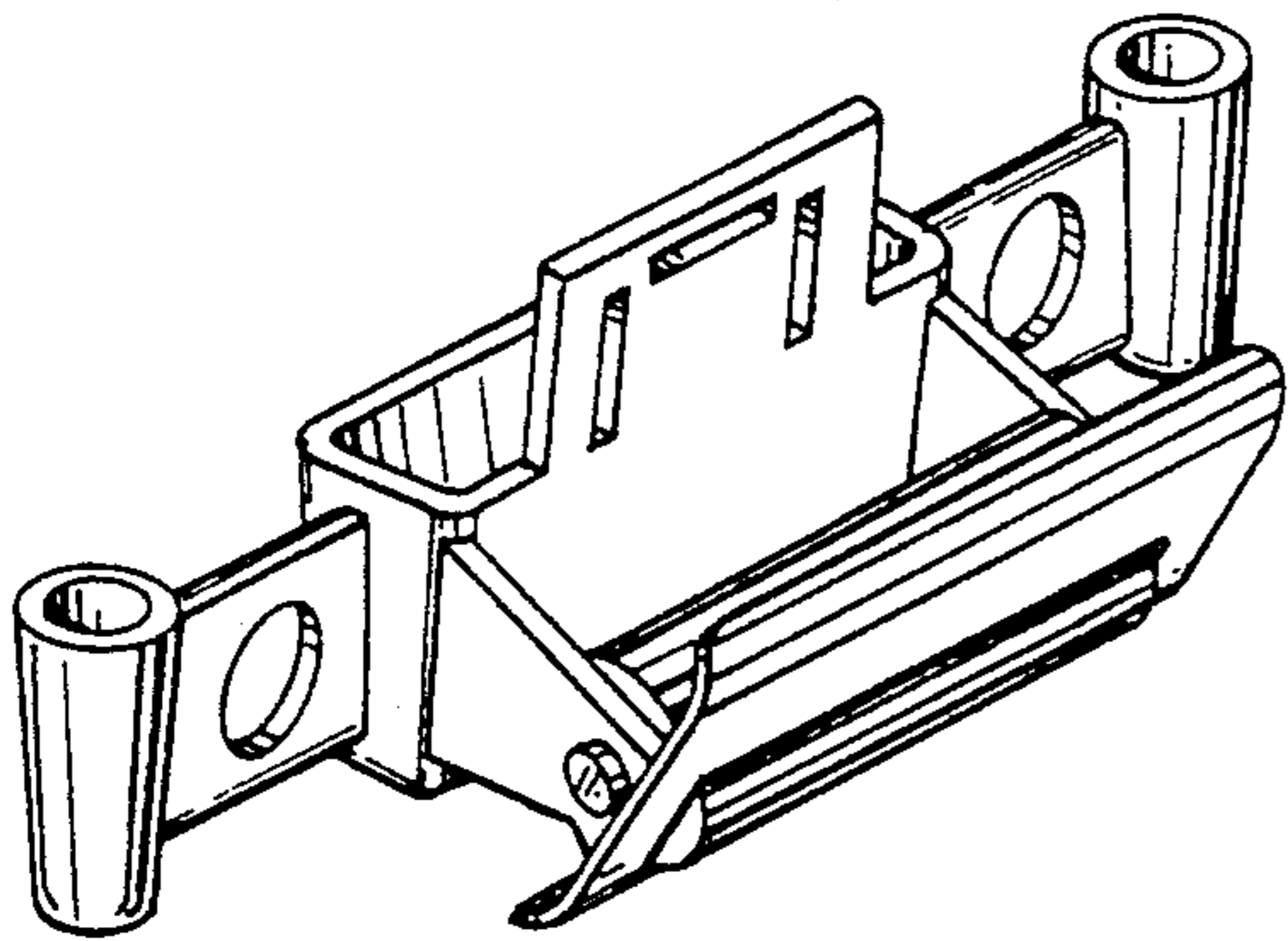

FIG. 1

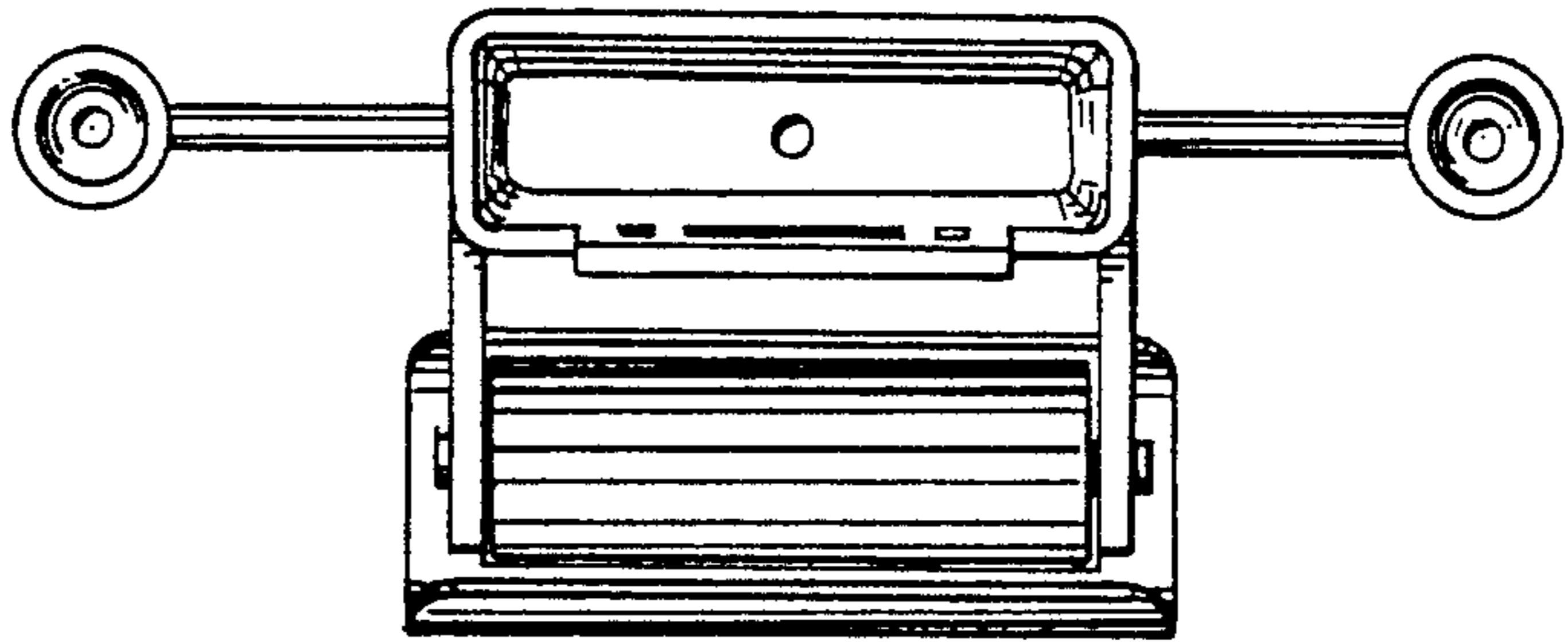

FIG. 2

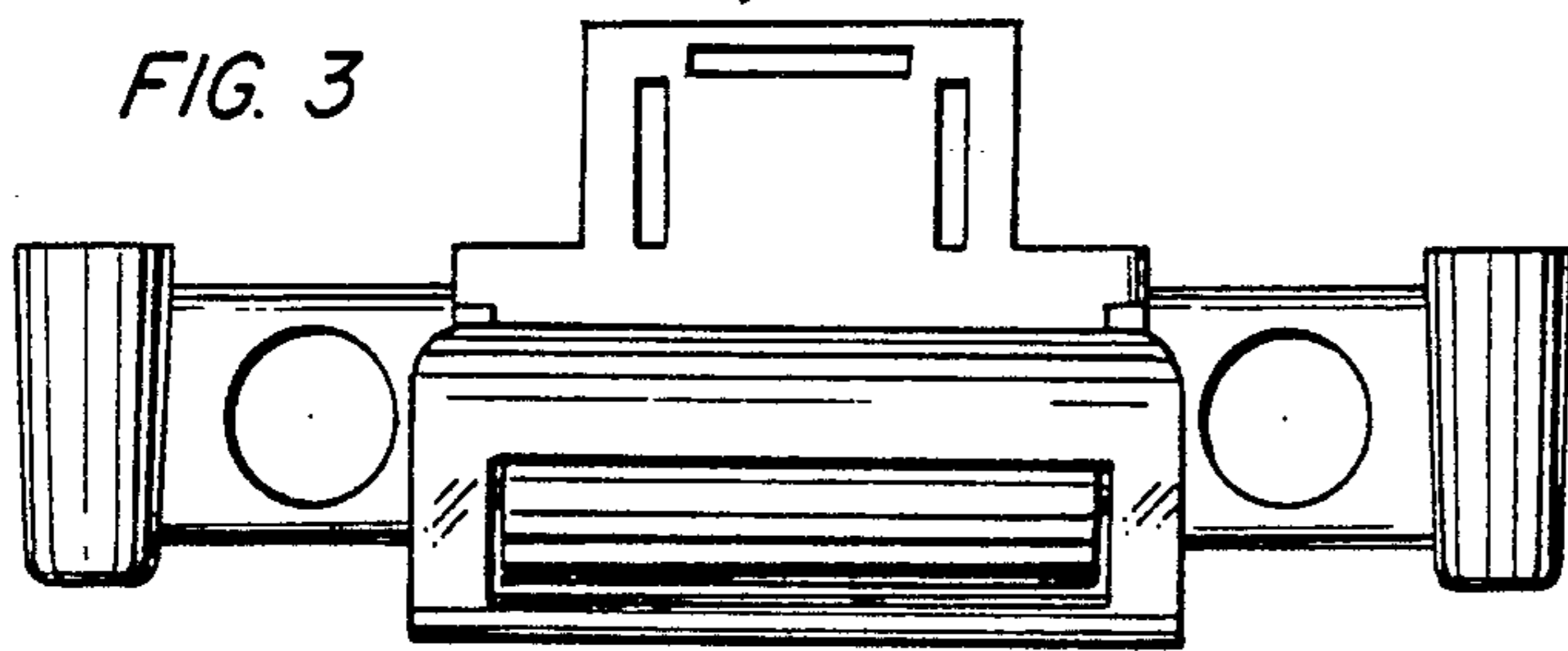

FIG. 3

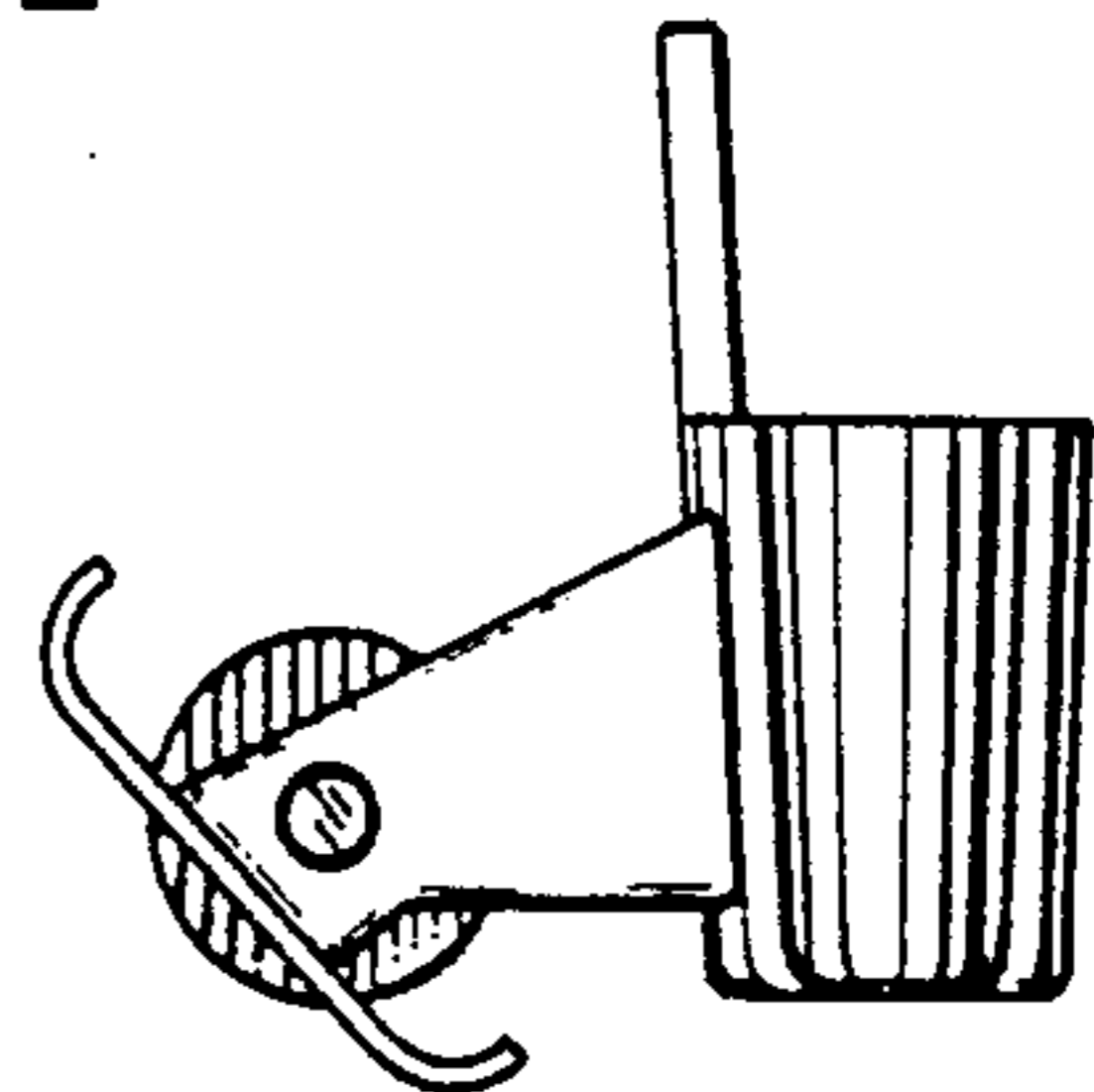

FIG. 4

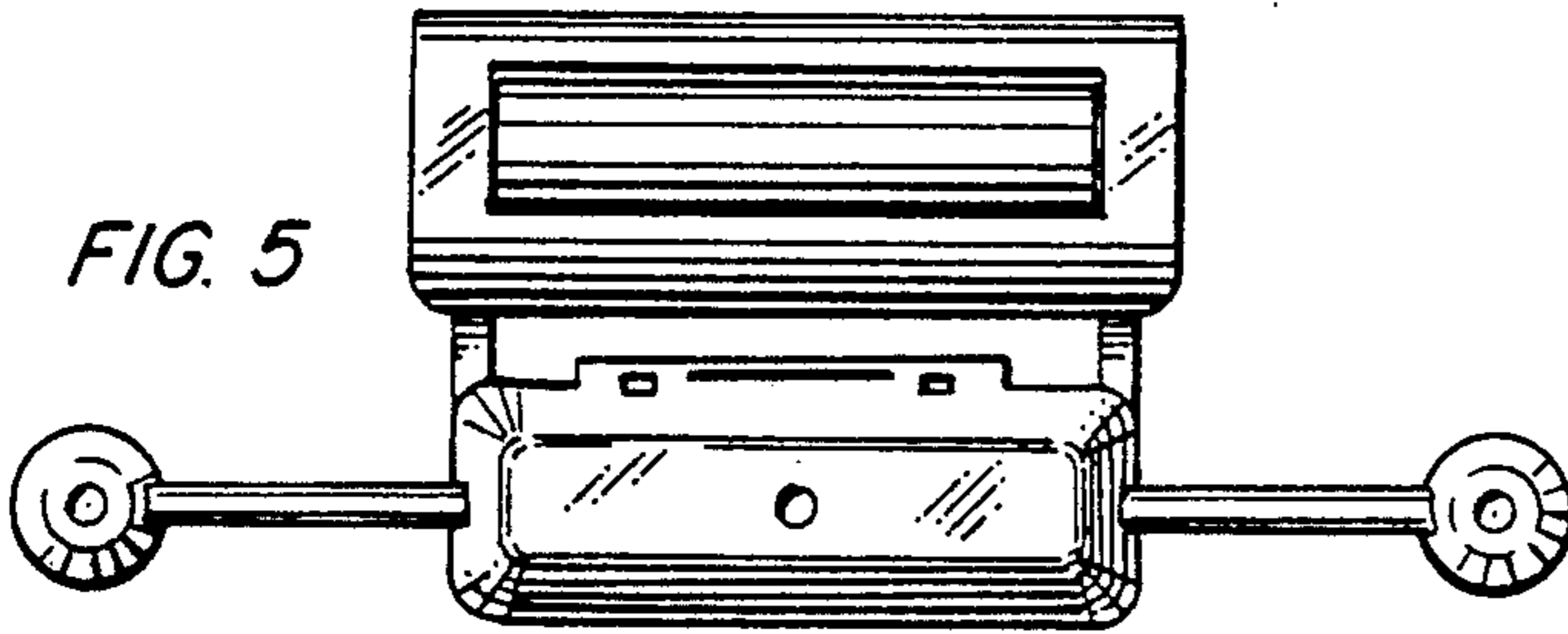

FIG. 5

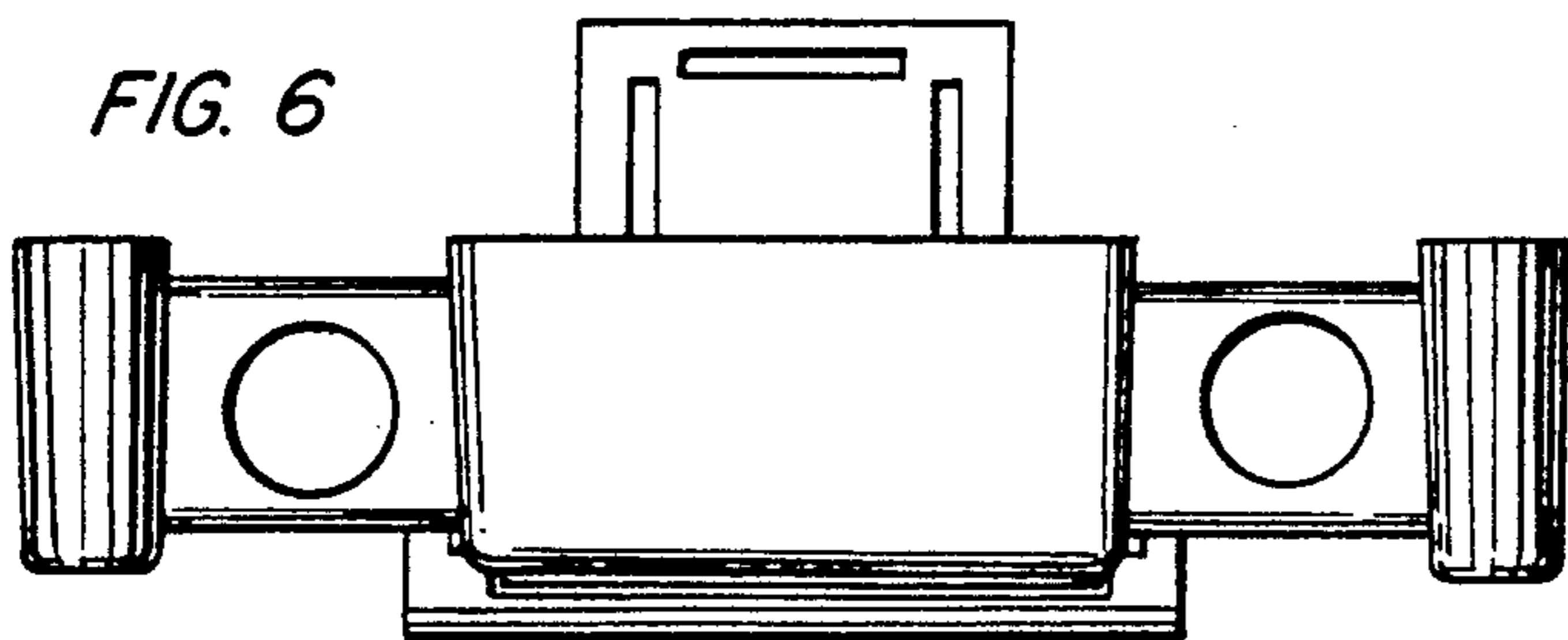

FIG. 6