



US00D327756S

# United States Patent [19]

[11] Patent Number: **Des. 327,756**

Klein et al.

[45] Date of Patent: **\*\* Jul. 7, 1992**

[54] **COMBINED STORAGE BINS AND CART THEREFOR**

[75] Inventors: **Shari G. Klein; Cheryl A. Hughes,** both of Seattle, Wash.

[73] Assignee: **Sterilite Corporation,** Townsend, Mass.

[\*\*] Term: **14 Years**

[21] Appl. No.: **575,509**

[22] Filed: **Aug. 29, 1990**

[52] U.S. Cl. .... **D34/1; D34/14; D34/20; D34/5**

[58] Field of Search ..... **D34/1, 5, 6, 7, 11, D34/12, 17, 24; 220/23.83, 23.4, 630, 324; 206/216; 280/47.26, 47.19**

[56] **References Cited**

**U.S. PATENT DOCUMENTS**

- D. 231,722 6/1974 Mockler ..... D34/5
- D. 299,578 1/1989 Wilson ..... D34/5
- 4,930,653 6/1990 Machado ..... 220/23.83

*Primary Examiner*—**Kay H. Chin**

*Attorney, Agent, or Firm*—**Graybeal, Jackson, Haley & Johnson**

[57] **CLAIM**

The ornamental design for combined storage bins and cart therefor, as shown and described.

**DESCRIPTION**

FIG. 1 is a top perspective view of a combined storage

bins and cart therefor showing our new design, with the lid of one storage bin being opened and the bin being elevated from the bottom of the cart;

FIG. 2 is a front elevational view of one of the storage bins;

FIG. 3 is a rear elevational view of FIG. 2;

FIG. 4 is a side elevational view of FIG. 2, the opposite side view being a mirror image of that shown;

FIG. 5 is a top plan view of FIG. 2;

FIG. 6 is a bottom plan view of FIG. 2;

FIG. 7 is a front elevational view of the cart;

FIG. 8 is a rear elevational view of FIG. 7;

FIG. 9 is a side elevational view of FIG. 7, the opposite side view being a mirror image of that shown;

FIG. 10 is a top plan view of FIG. 9;

FIG. 11 is a bottom plan view of FIG. 9;

FIG. 12 is a front elevational view of a second embodiment view of a second embodiment of the cart;

FIG. 13 is a rear elevational view of FIG. 12;

FIG. 14 is a side elevational view of FIG. 12, the opposite side view being a mirror image of that shown;

FIG. 15 is a top plan view of FIG. 12;

FIG. 16 is a front elevational view of a third embodiment of the cart;

FIG. 17 is a rear elevational view of FIG. 16;

FIG. 18 is a side elevational view of FIG. 16; the opposite side view being a mirror image of that shown;

FIG. 19 is a top plan view of FIG. 16; and,

FIG. 20 is a bottom plan view of FIG. 16.

The undisclosed bottom of the second and third embodiment being the same as the first embodiment shown in FIG. 11.

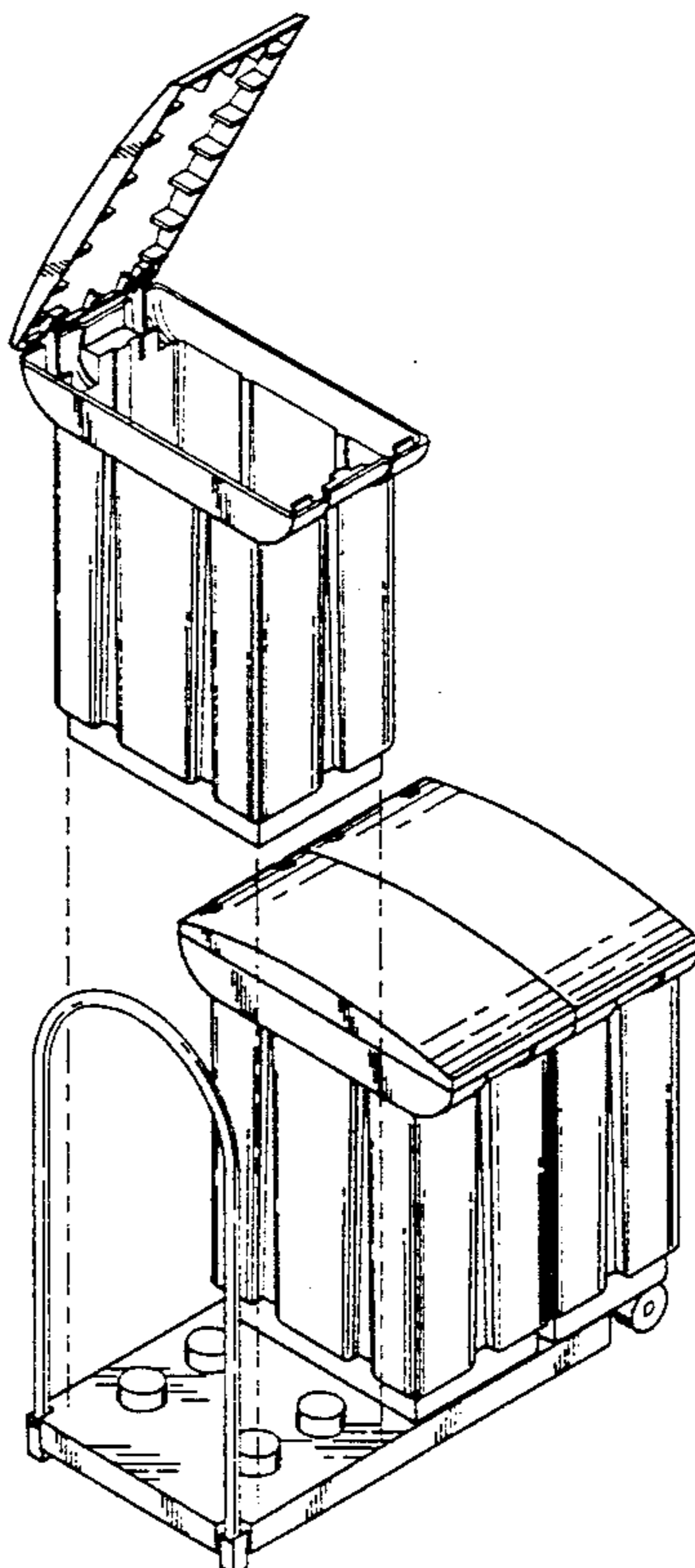

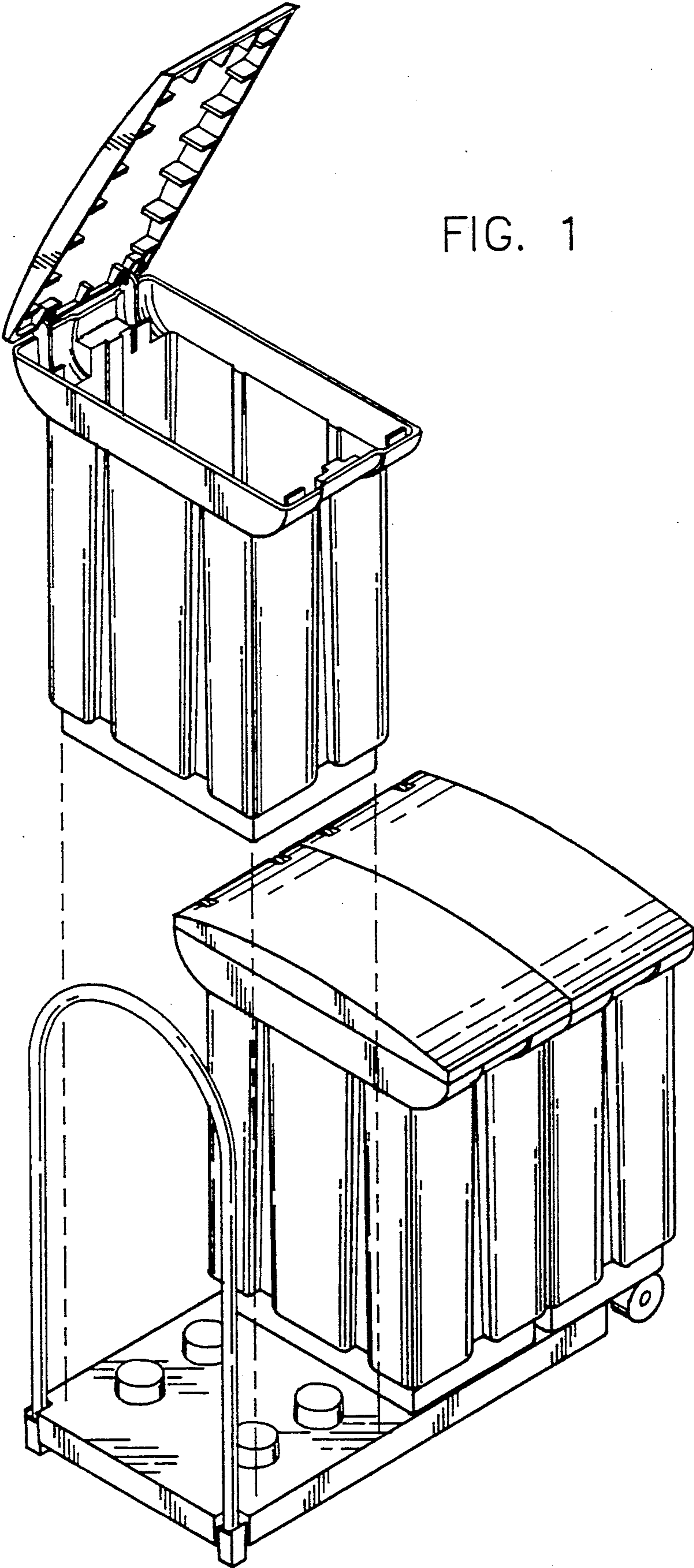

FIG. 1

FIG. 2

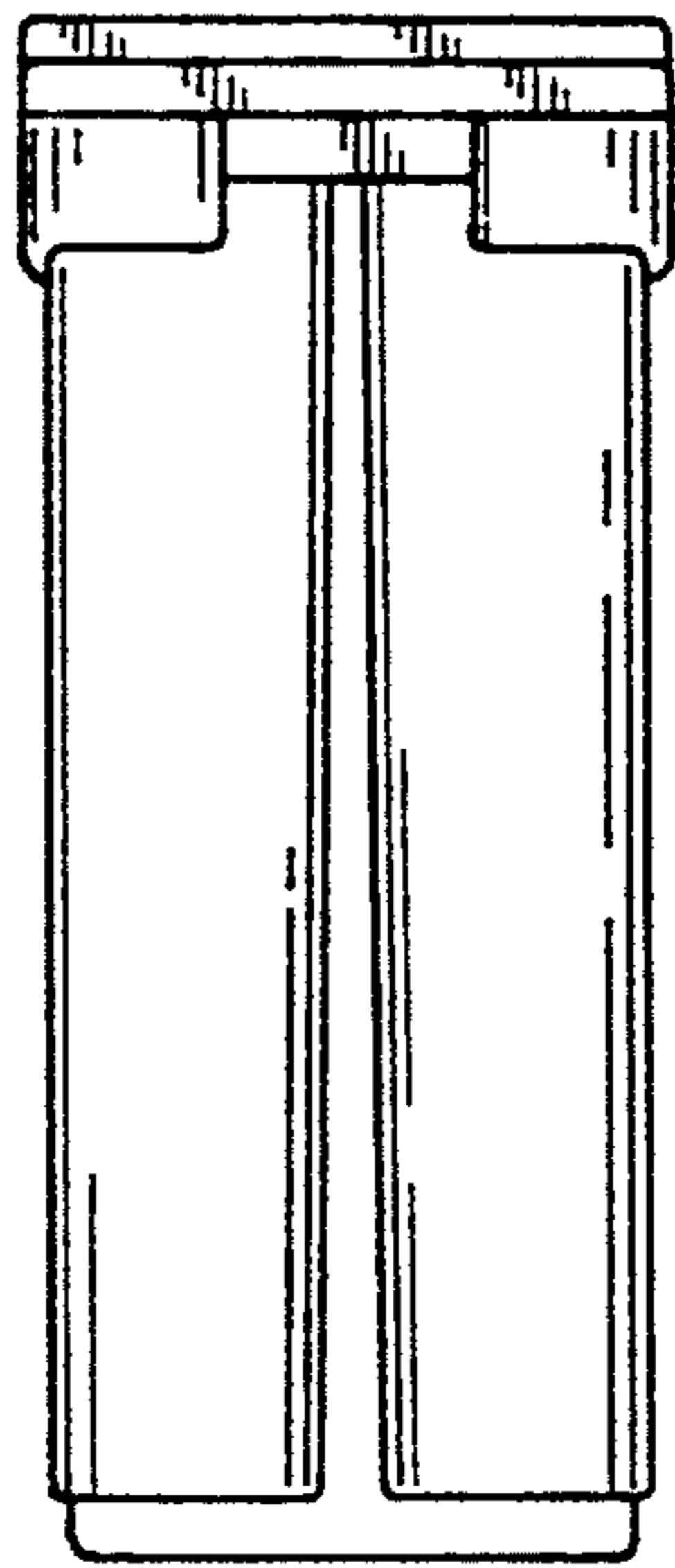

FIG. 3

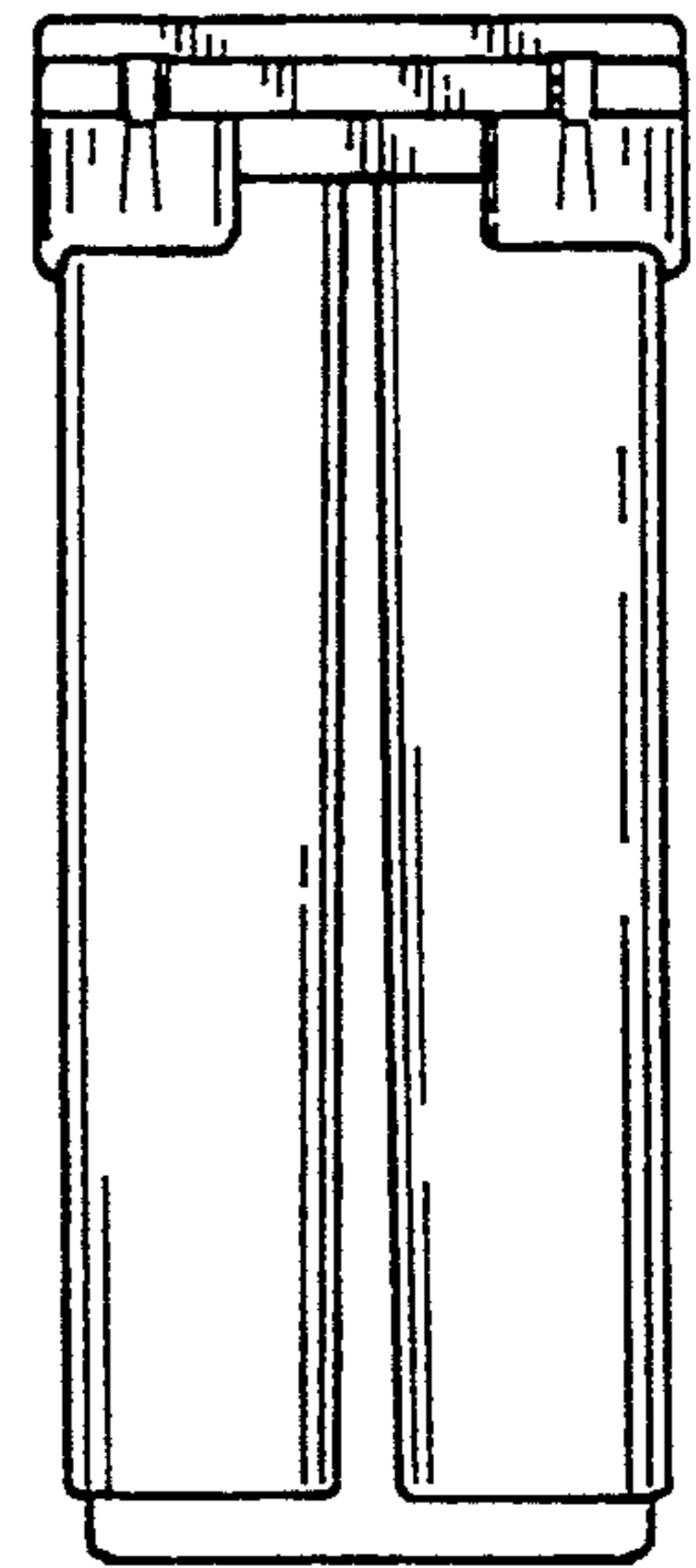

FIG. 4

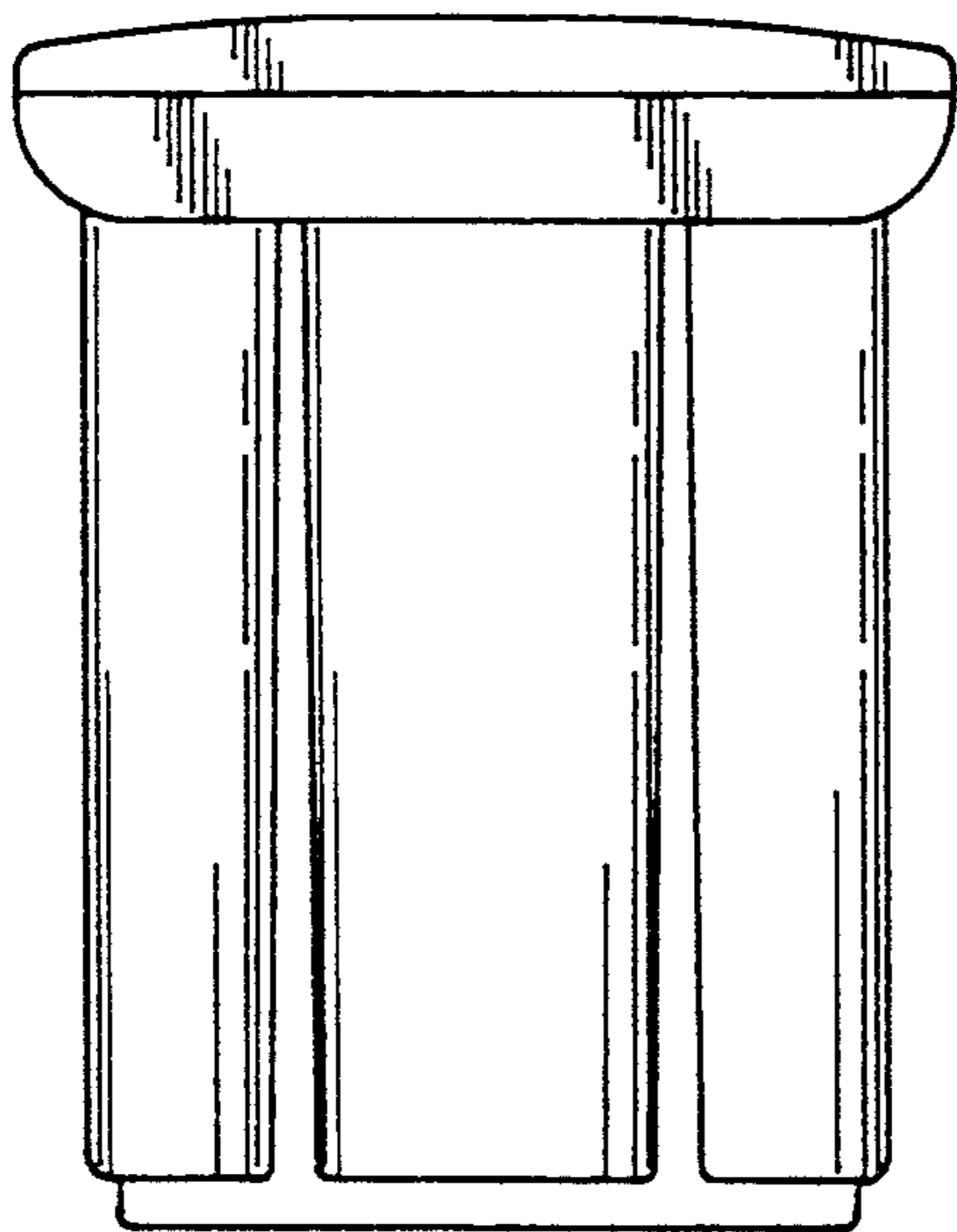

FIG. 5

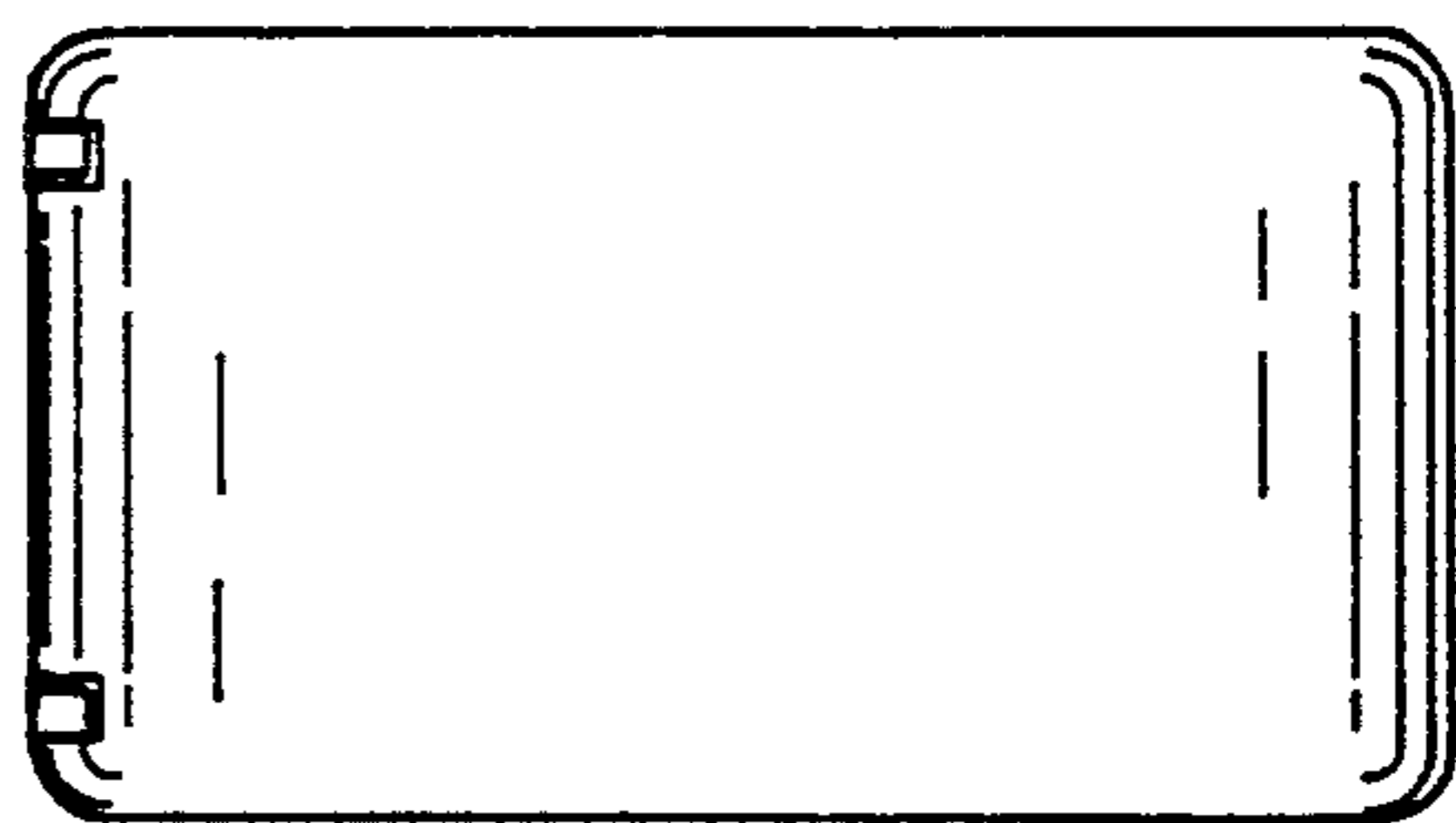

FIG. 6

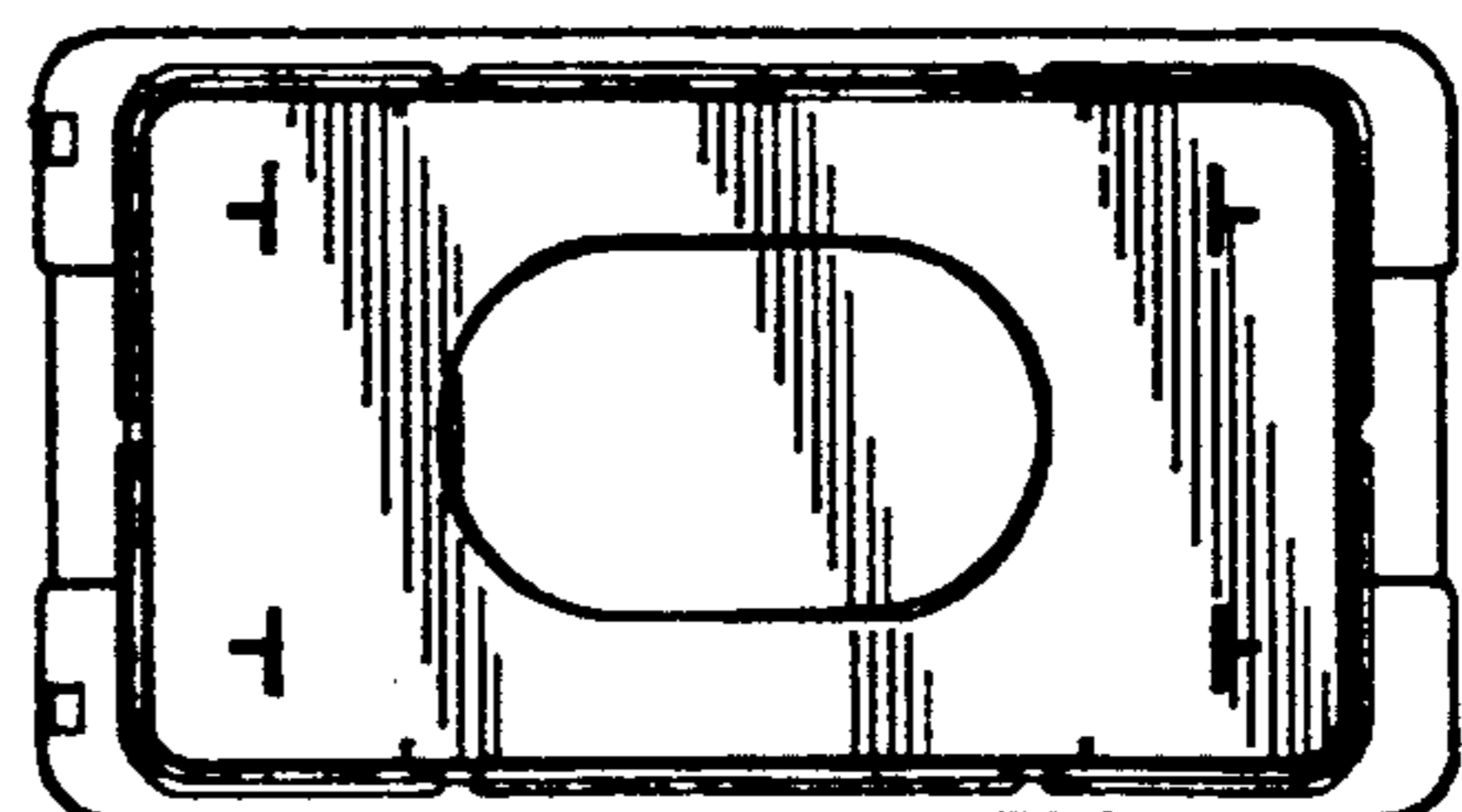

FIG. 7

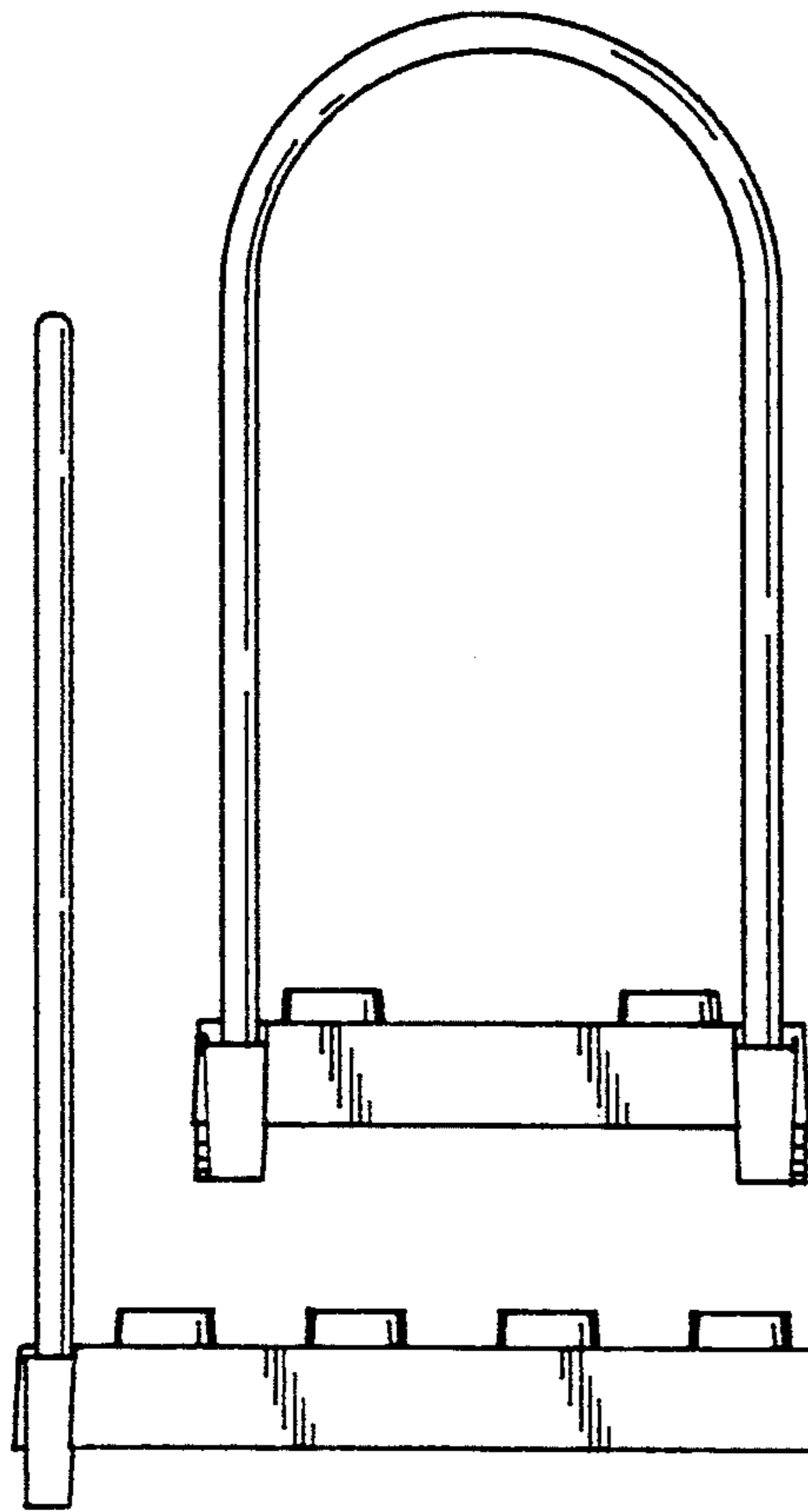

FIG. 8

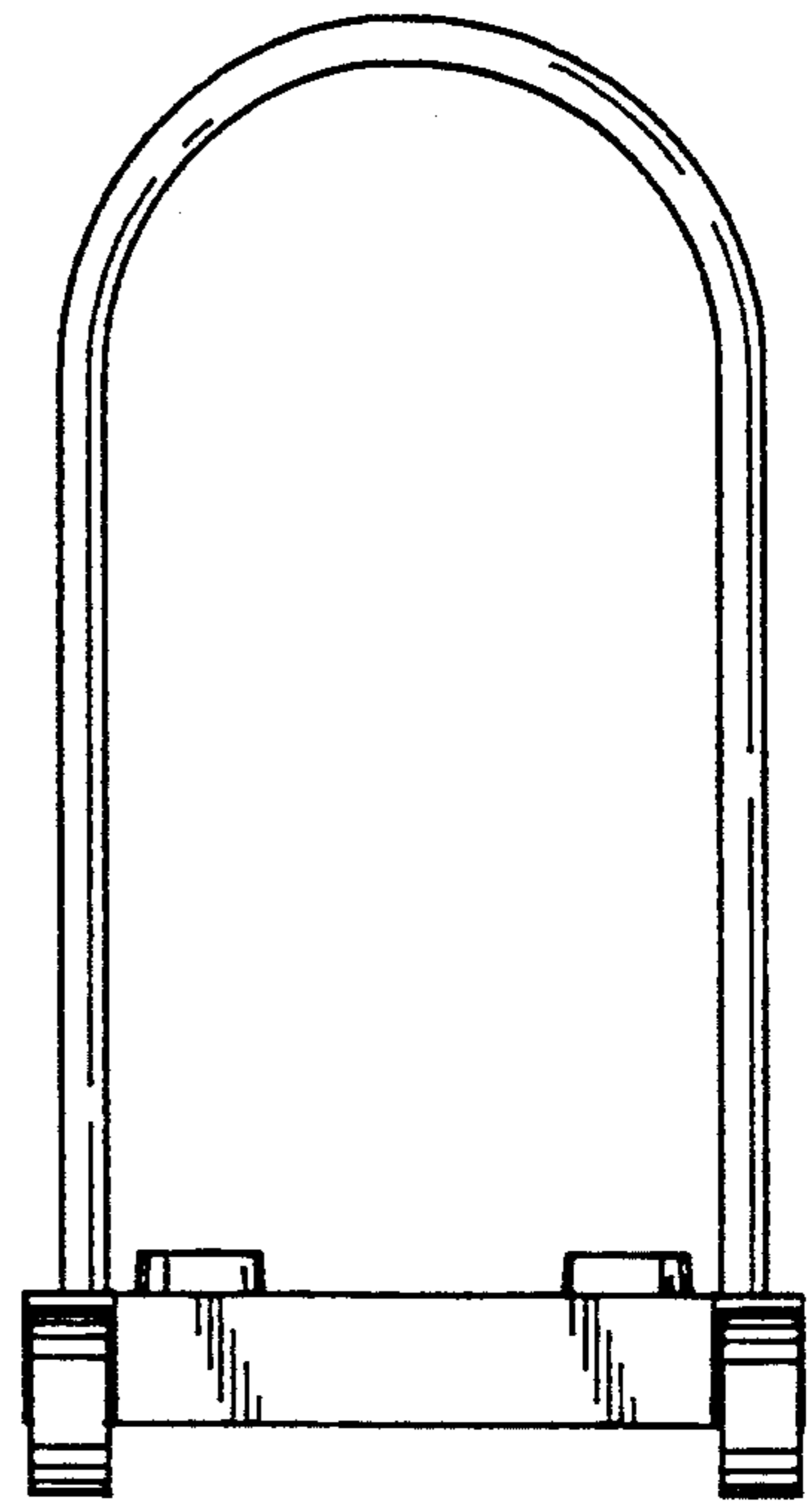

FIG. 9

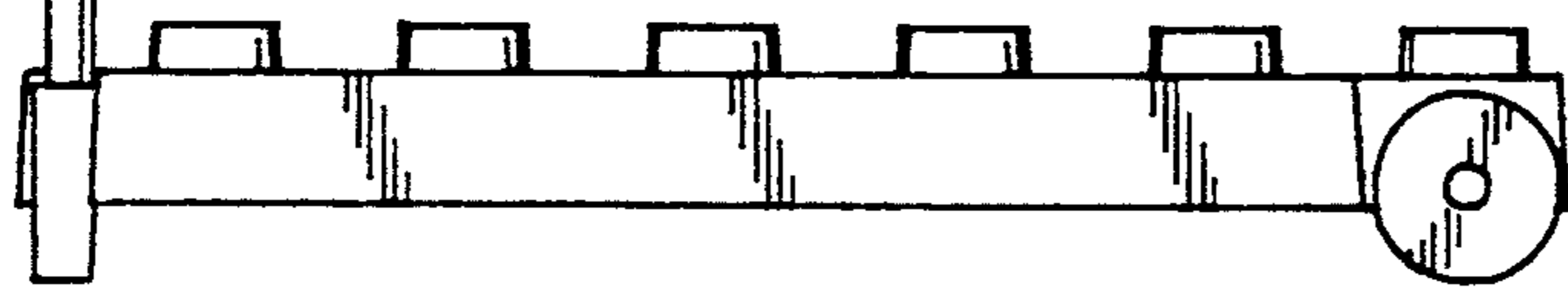

FIG. 10

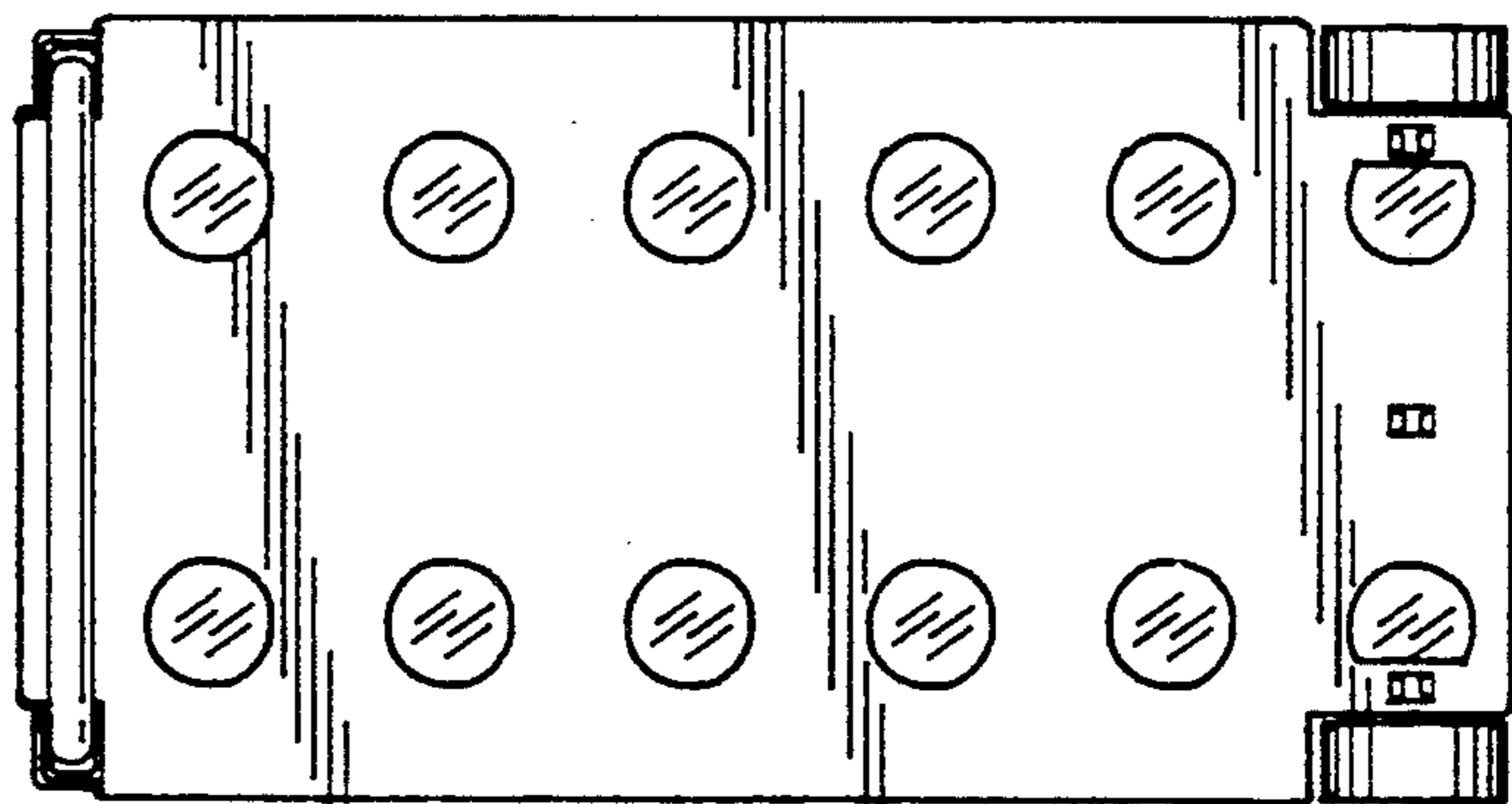

FIG. 11

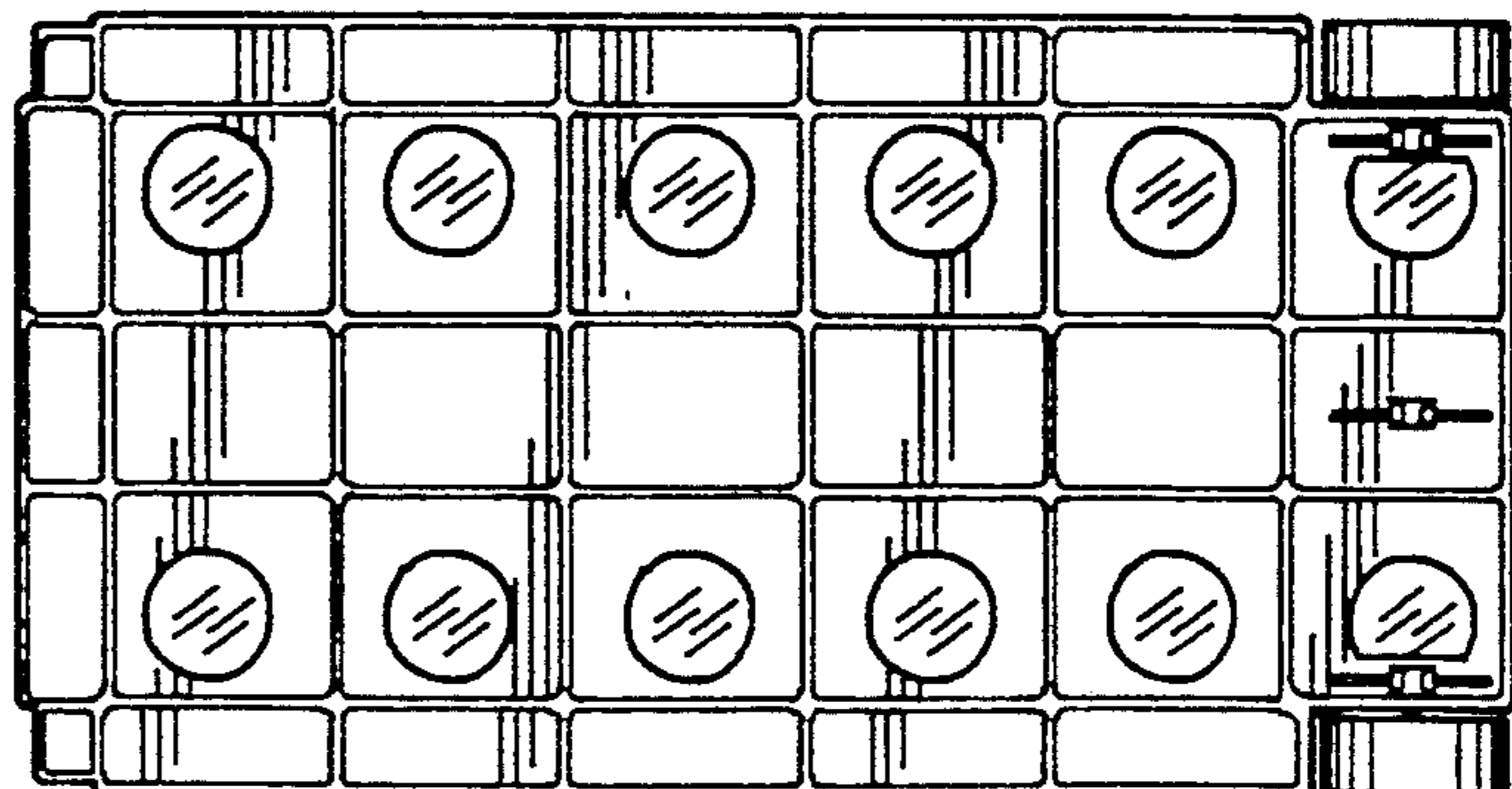

FIG. 12

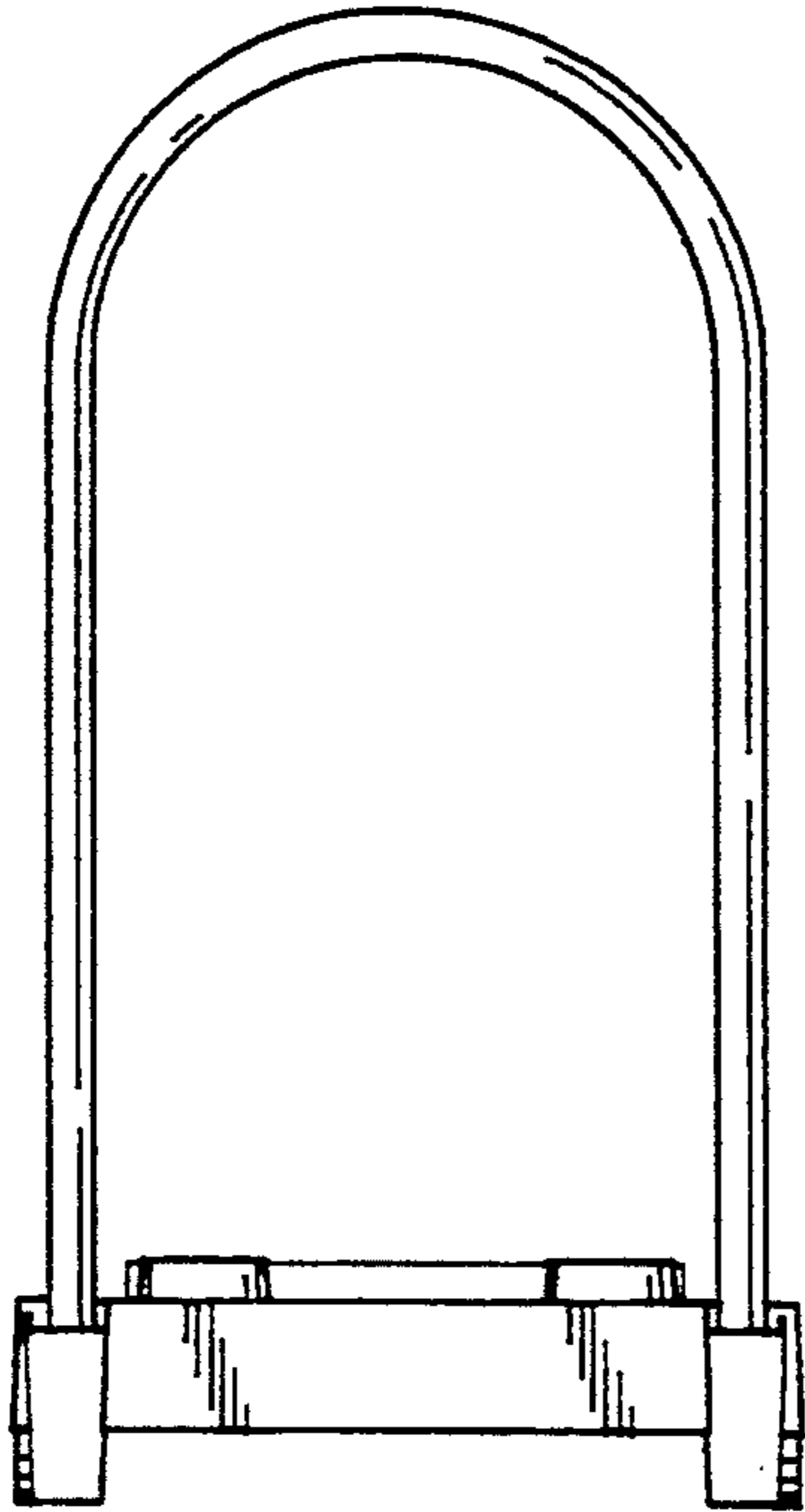

FIG. 13

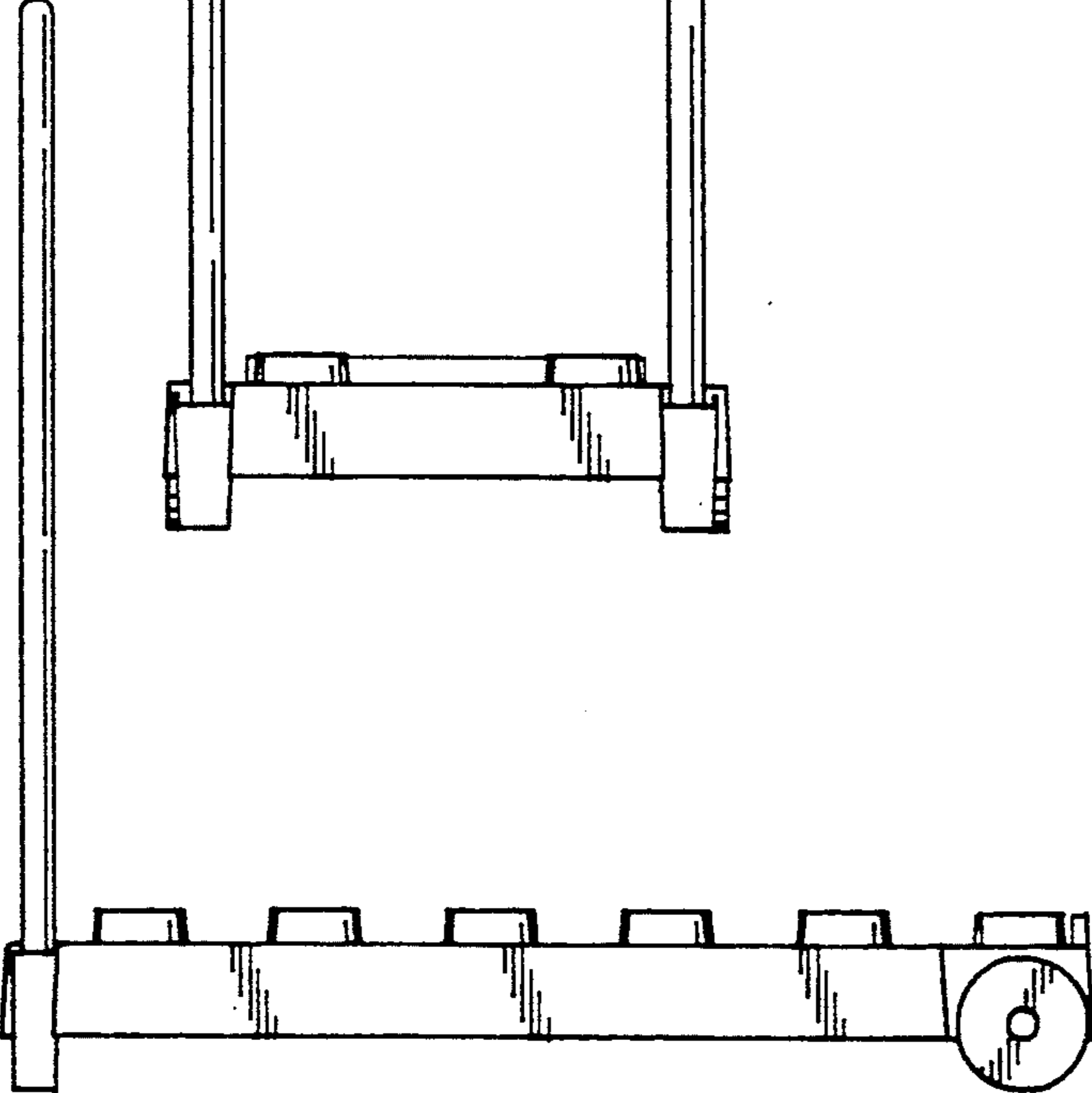
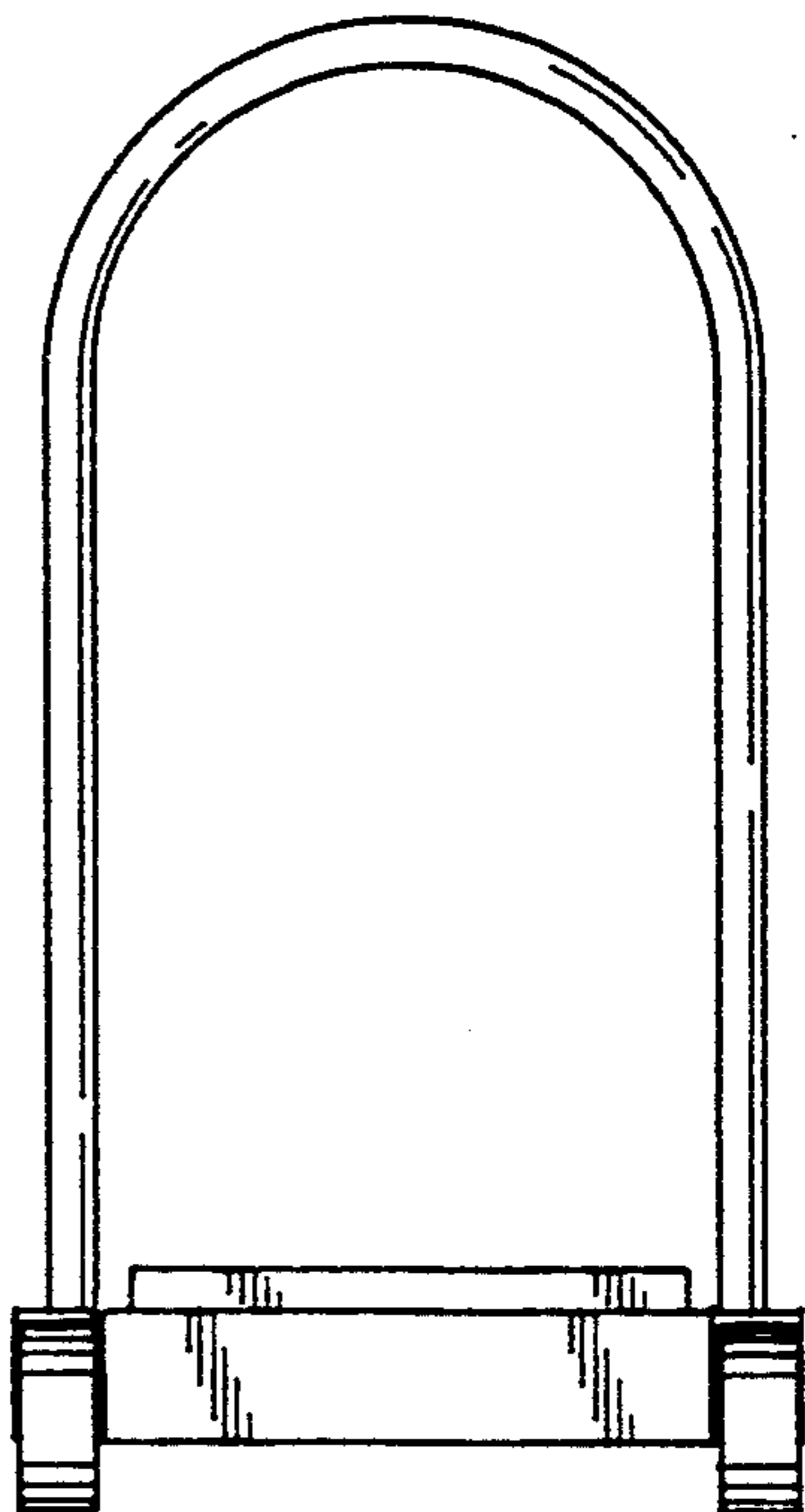

FIG. 14

FIG. 15

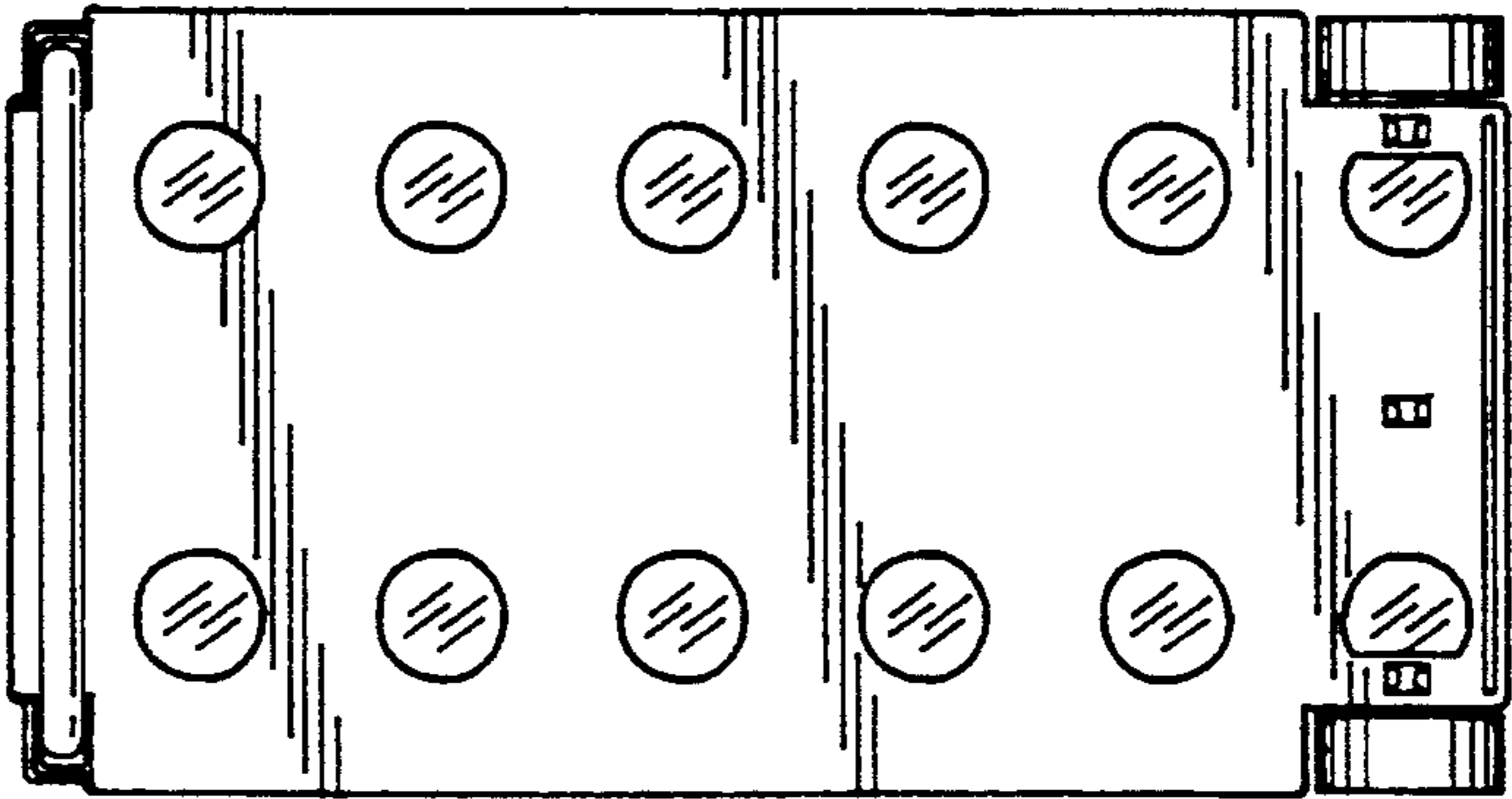

FIG. 16

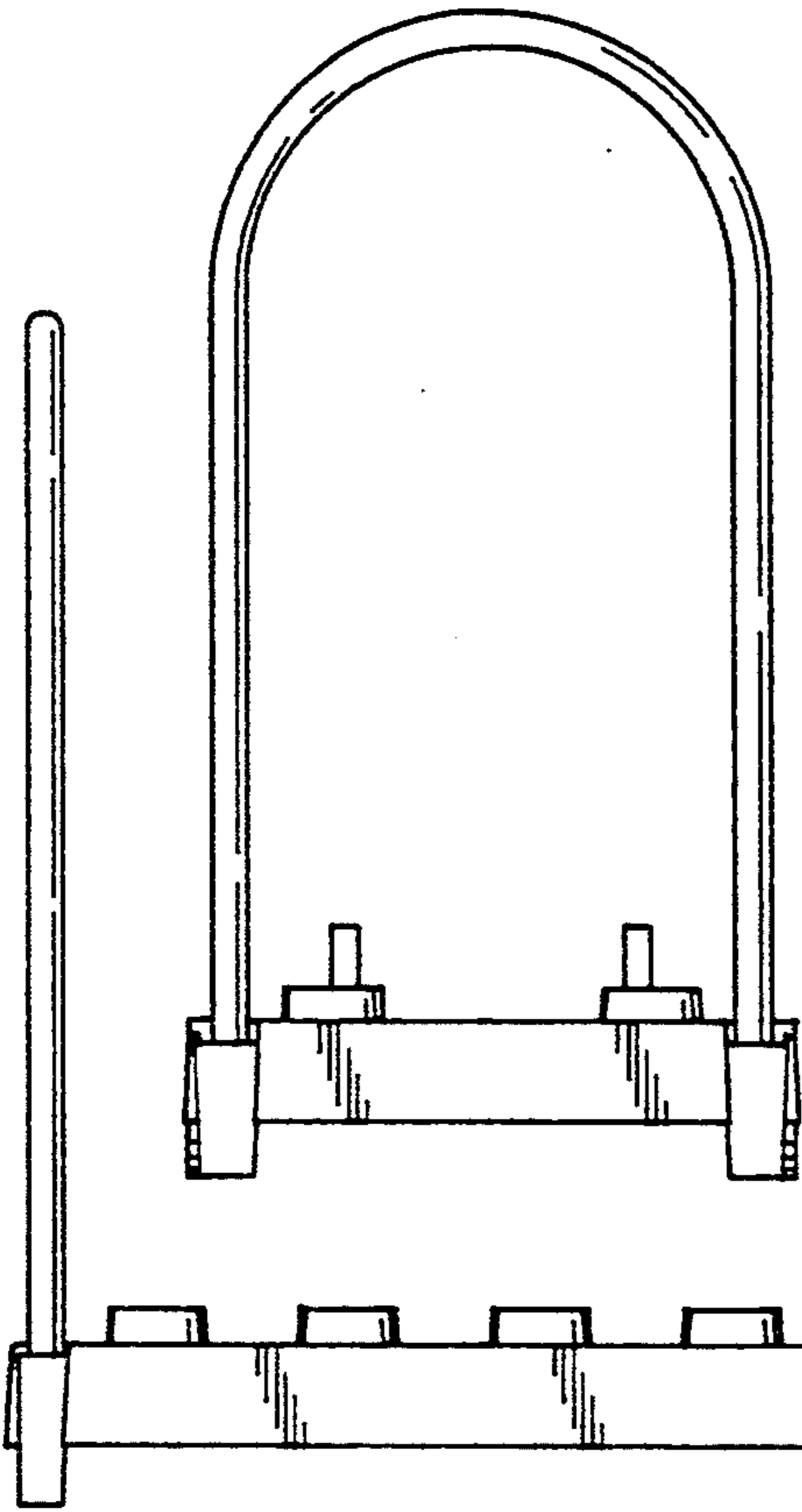

FIG. 17

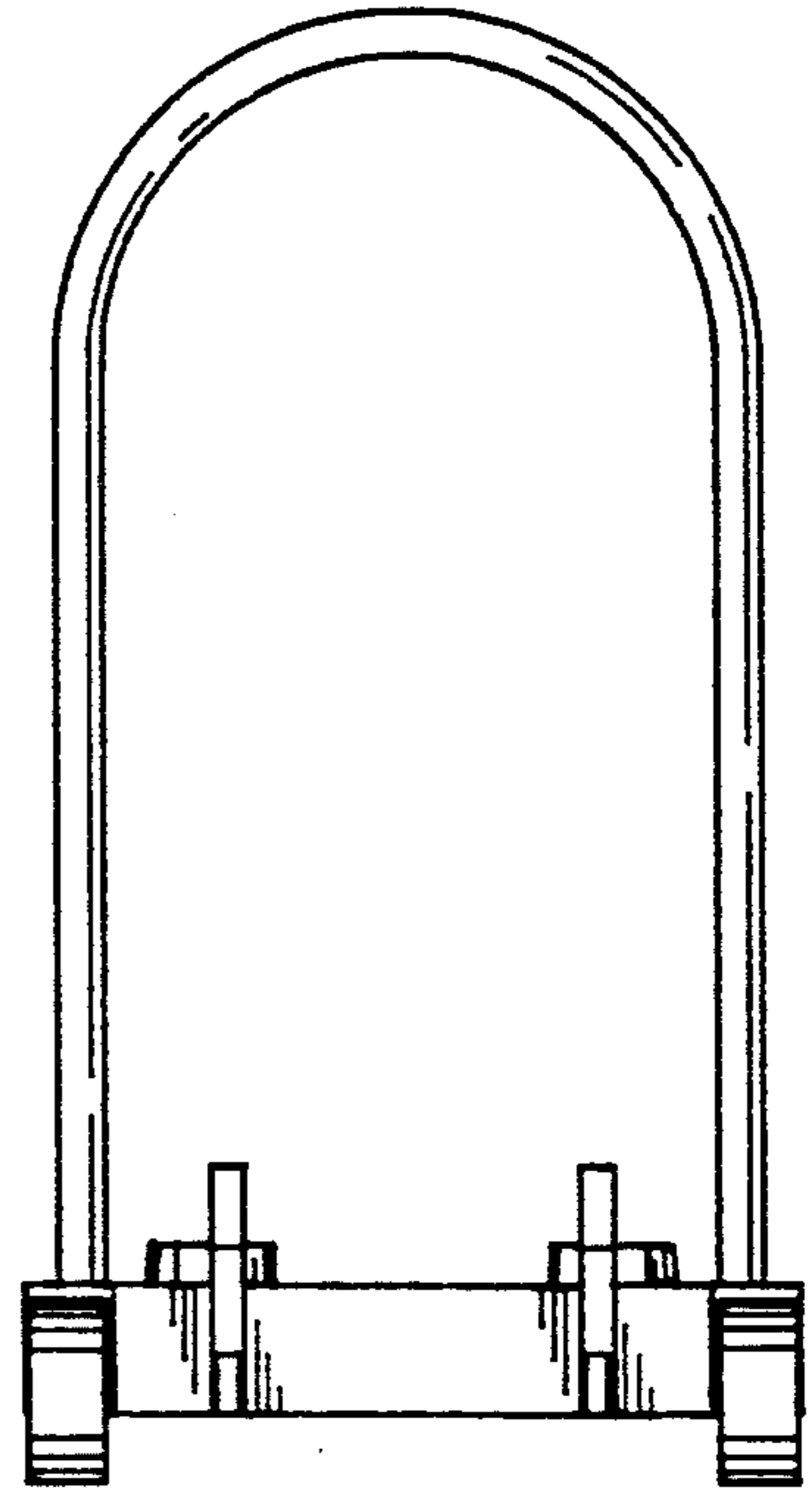

FIG. 18

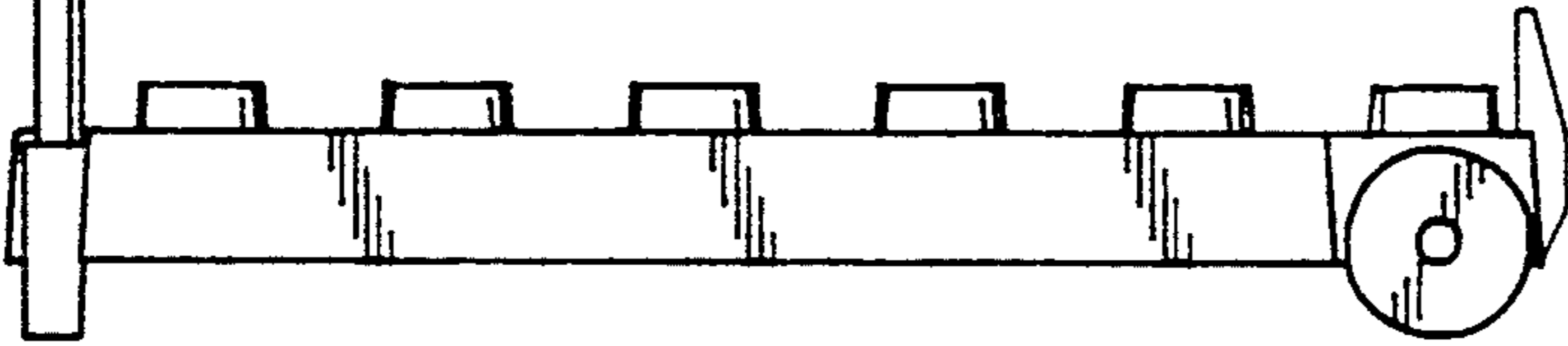

FIG. 19

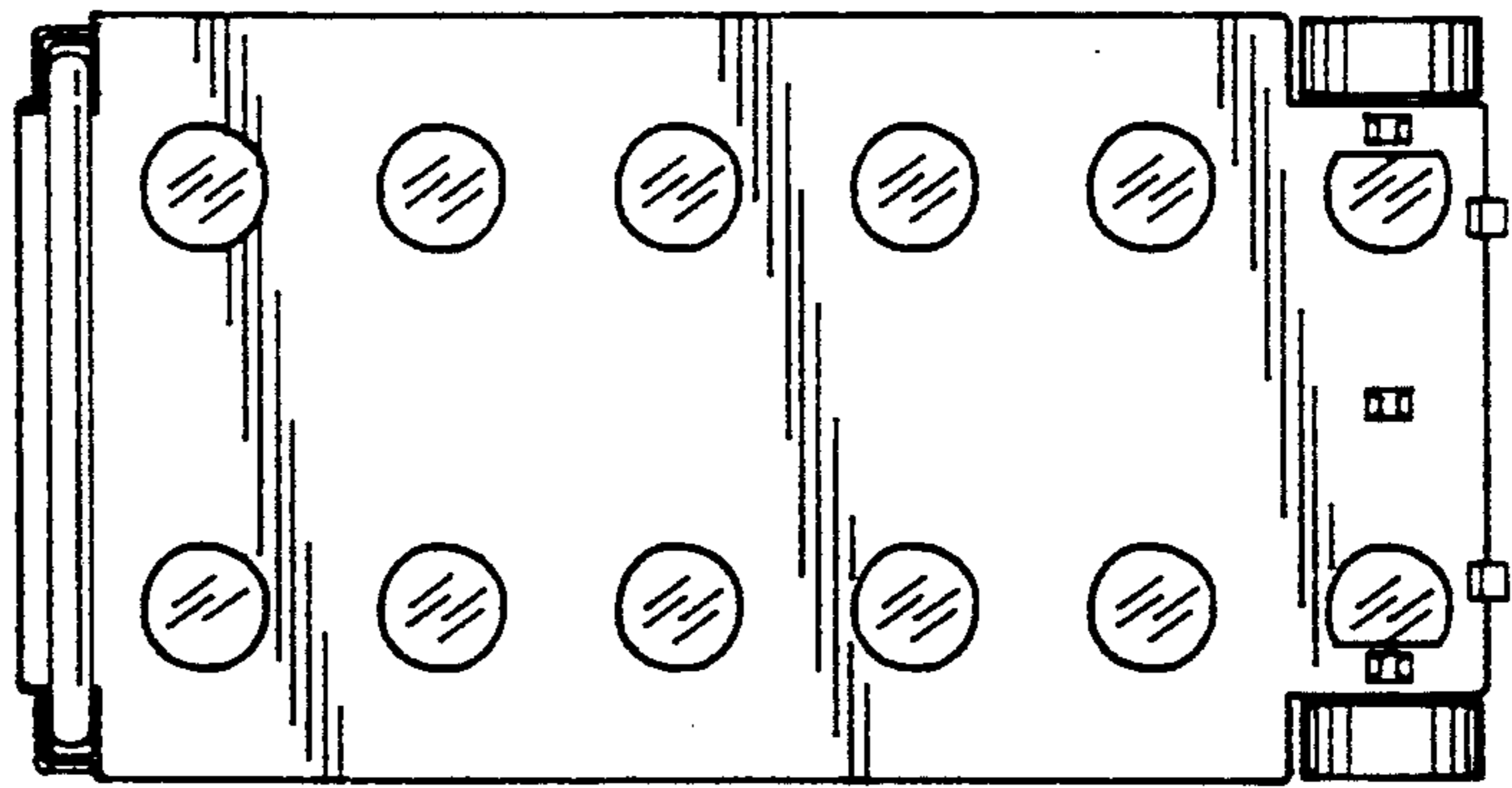

FIG. 20

