



US00D327658S

# United States Patent [19]

[11] Patent Number: Des. 327,658

Kulp et al.

[45] Date of Patent: \*\* Jul. 7, 1992

## [54] FRAME FOR A TRAFFIC BARRICADE

[75] Inventors: Jack H. Kulp, San Juan Capistrano; James P. Sullivan, Orange, both of Calif.

[73] Assignee: Traffix Devices, Inc., San Clemente, Calif.

[\*\*] Term: 14 Years

[21] Appl. No.: 700,906

[22] Filed: May 16, 1991

[52] U.S. Cl. .... D10/109; D10/113

[58] Field of Search ..... D10/109, 111, 113; 404/6, 7, 8, 9, 10, 11, 12, 13, 14, 15, 16; 116/63 R, 63 P, 63 T; 256/64

## [56] References Cited

### U.S. PATENT DOCUMENTS

1,408,675	3/1922	Wimberg	.....	D10/109
1,687,820	10/1928	Acker	.	
2,249,685	7/1941	Dearing	.....	D10/109
2,824,719	2/1958	Nutting	.....	D10/109
2,986,230	5/1961	Zutsche	.....	D10/109
3,456,100	7/1969	Green	.....	116/63 T
3,917,232	11/1975	Lindner	.....	D10/109
3,950,873	4/1976	Stehle et al.	.....	40/125 H
4,071,224	1/1978	Gilbert	.....	256/64
4,859,983	8/1989	Kulp et al.	.....	404/6

Primary Examiner—Wallace R. Burke  
Assistant Examiner—Marcus Jackson  
Attorney, Agent, or Firm—Edward J. DaRin

## [57] CLAIM

The ornamental design for a frame for a traffic barricade, as shown and described.

## DESCRIPTION

FIG. 1 is a reduced perspective view of a frame for a traffic barricade showing our new design with the broken lines shown for illustrative purposes only and forming no part of the claimed design;

FIG. 2 is a left side elevational view thereof, with the opposite side being a mirror image;

FIG. 3 is a front elevational view thereof;

FIG. 4 is a rear elevational view thereof;

FIG. 5 is a top plan view thereof;

FIG. 6 is a bottom plan view thereof;

FIG. 7 is a front elevational view of a second embodiment thereof;

FIG. 8 is a left side elevational view thereof; with the opposite side being a mirror image;

FIG. 9 is a top plan view thereof;

FIG. 10 is a bottom plan view thereof;

FIG. 11 is a rear elevational view thereof;

FIG. 12 is a sectional view taken along line 12—12 of FIG. 7; and,

FIG. 13 is a partial sectional view taken along line 13—13 of FIG. 7.

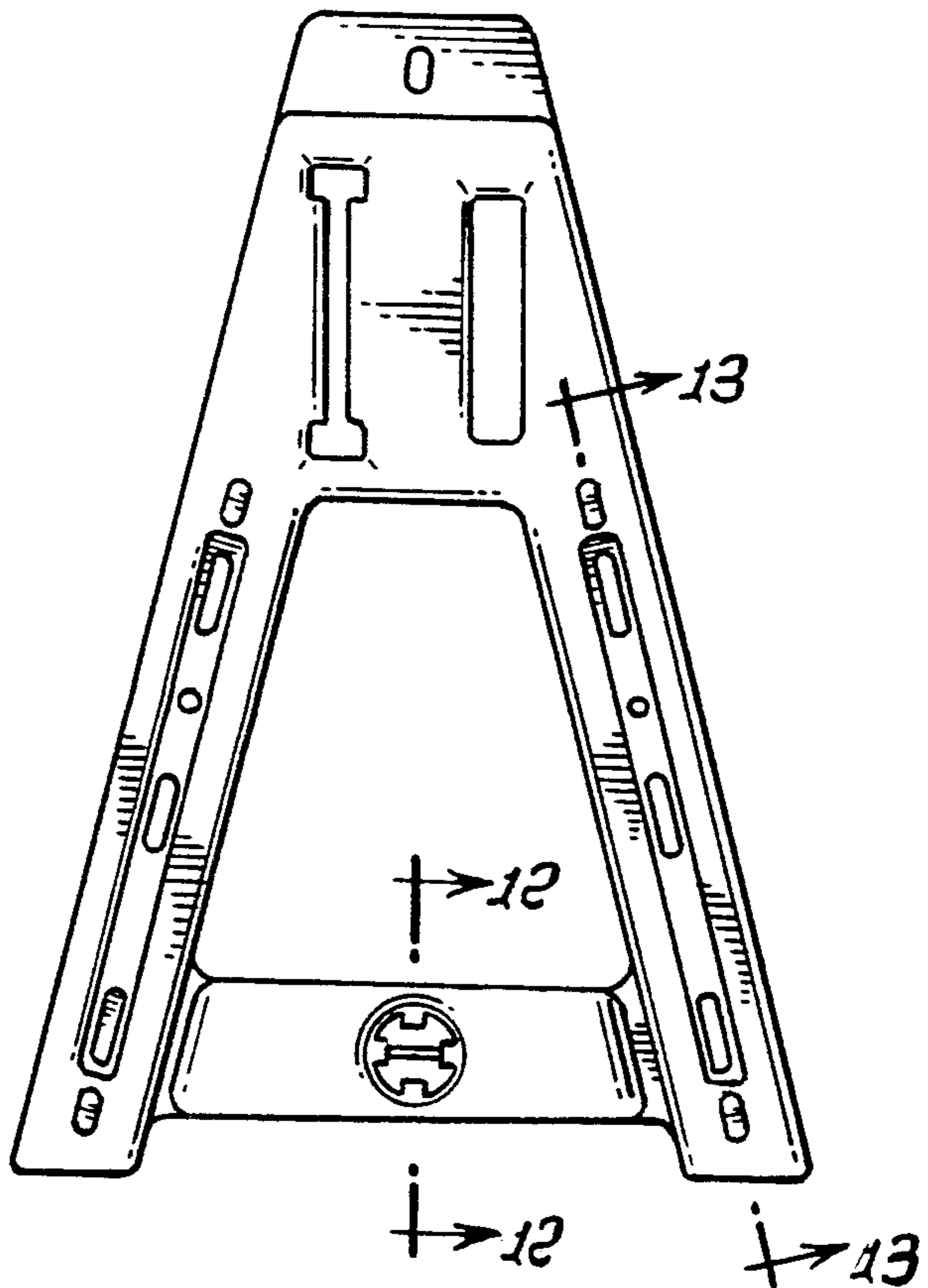
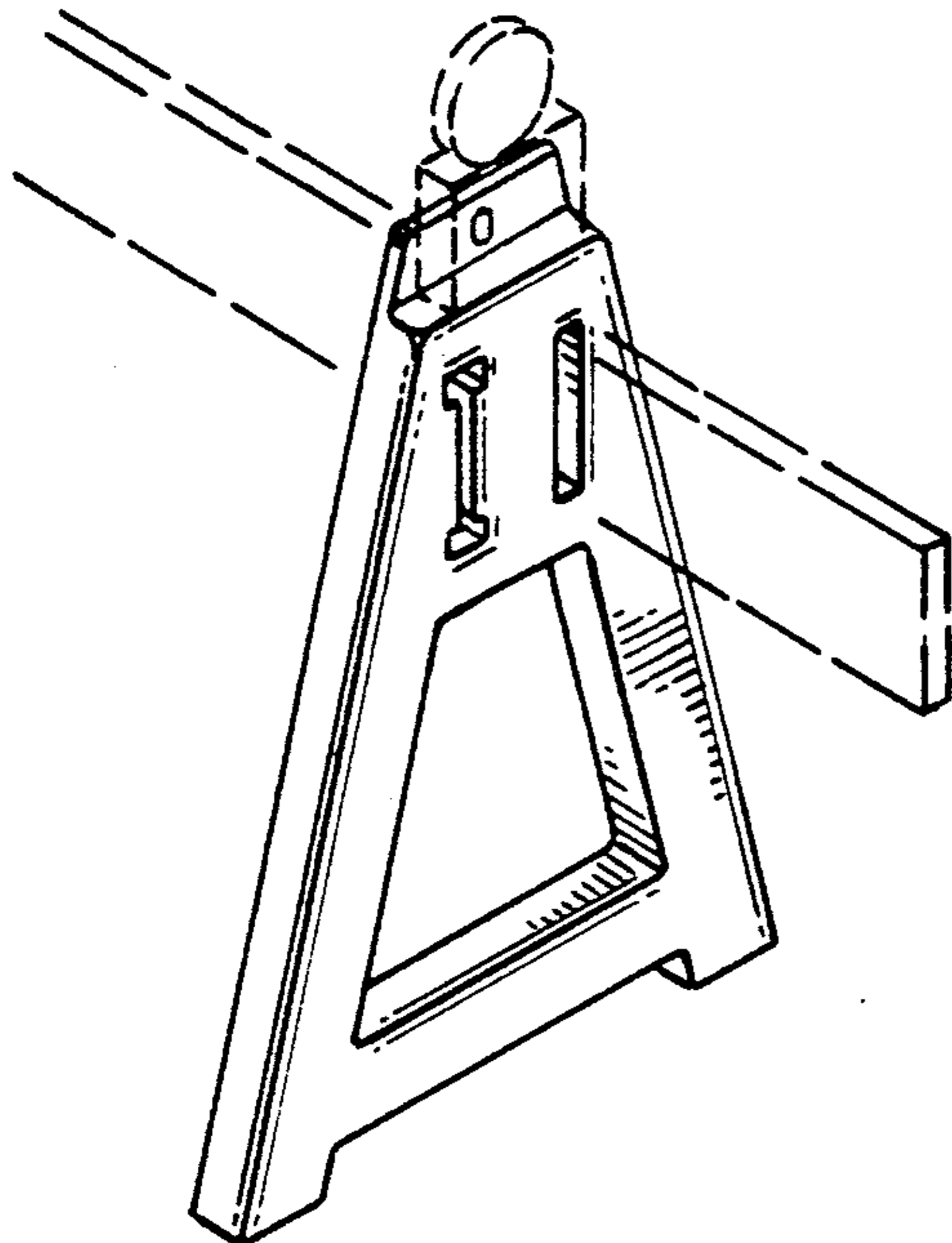

*FIG. 1.*

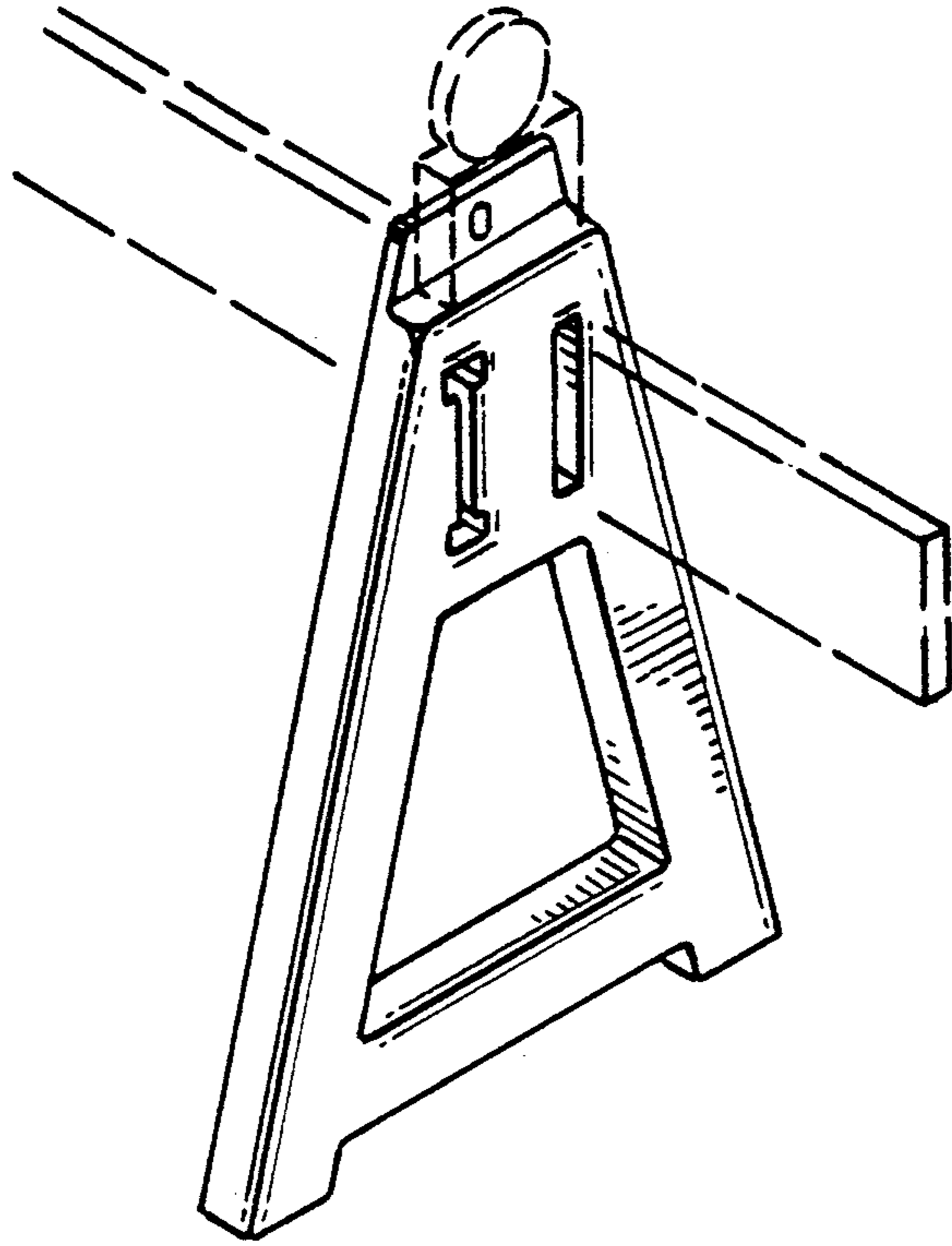

*FIG. 2.*



*FIG. 3.*

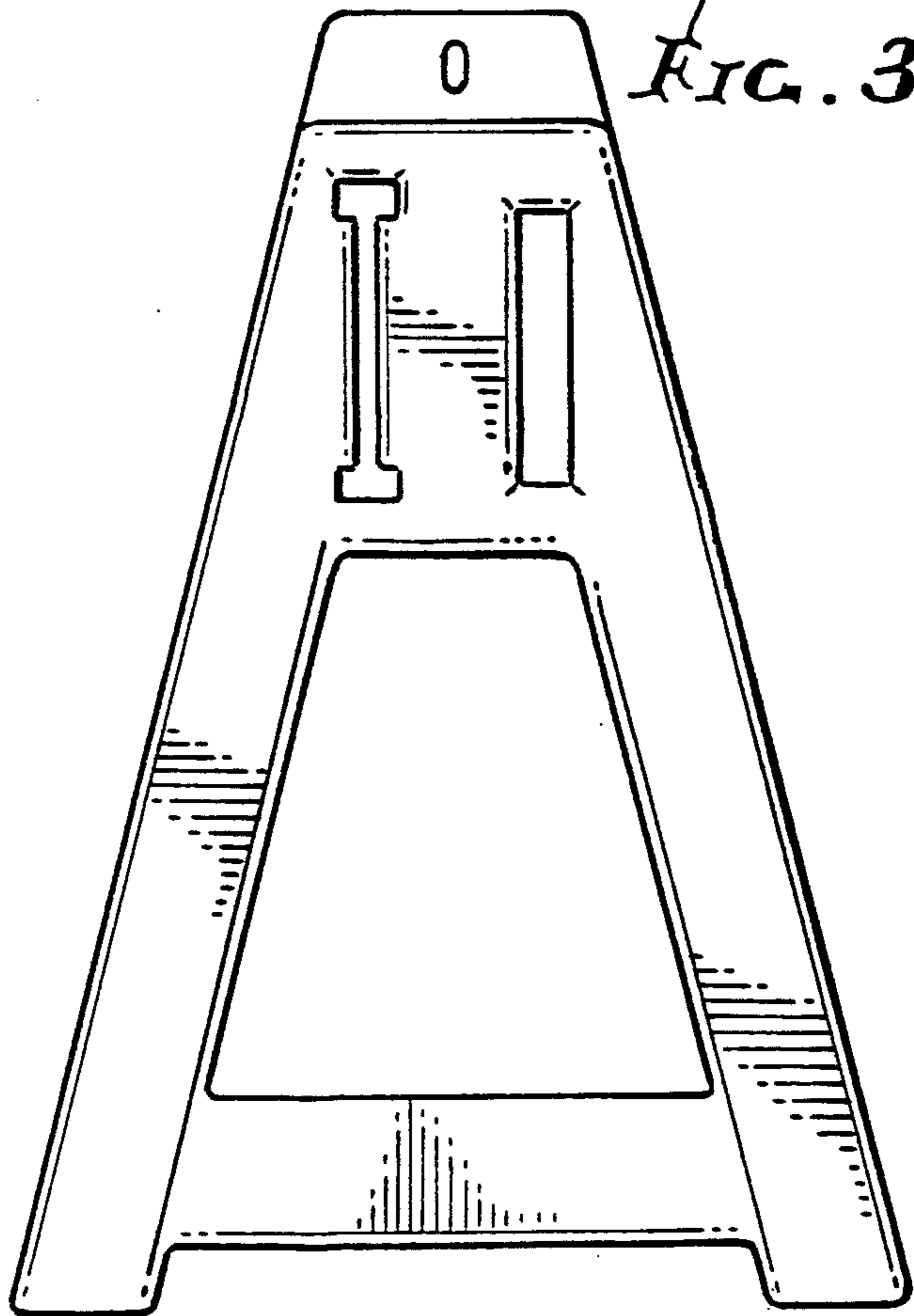

FIG. 4.

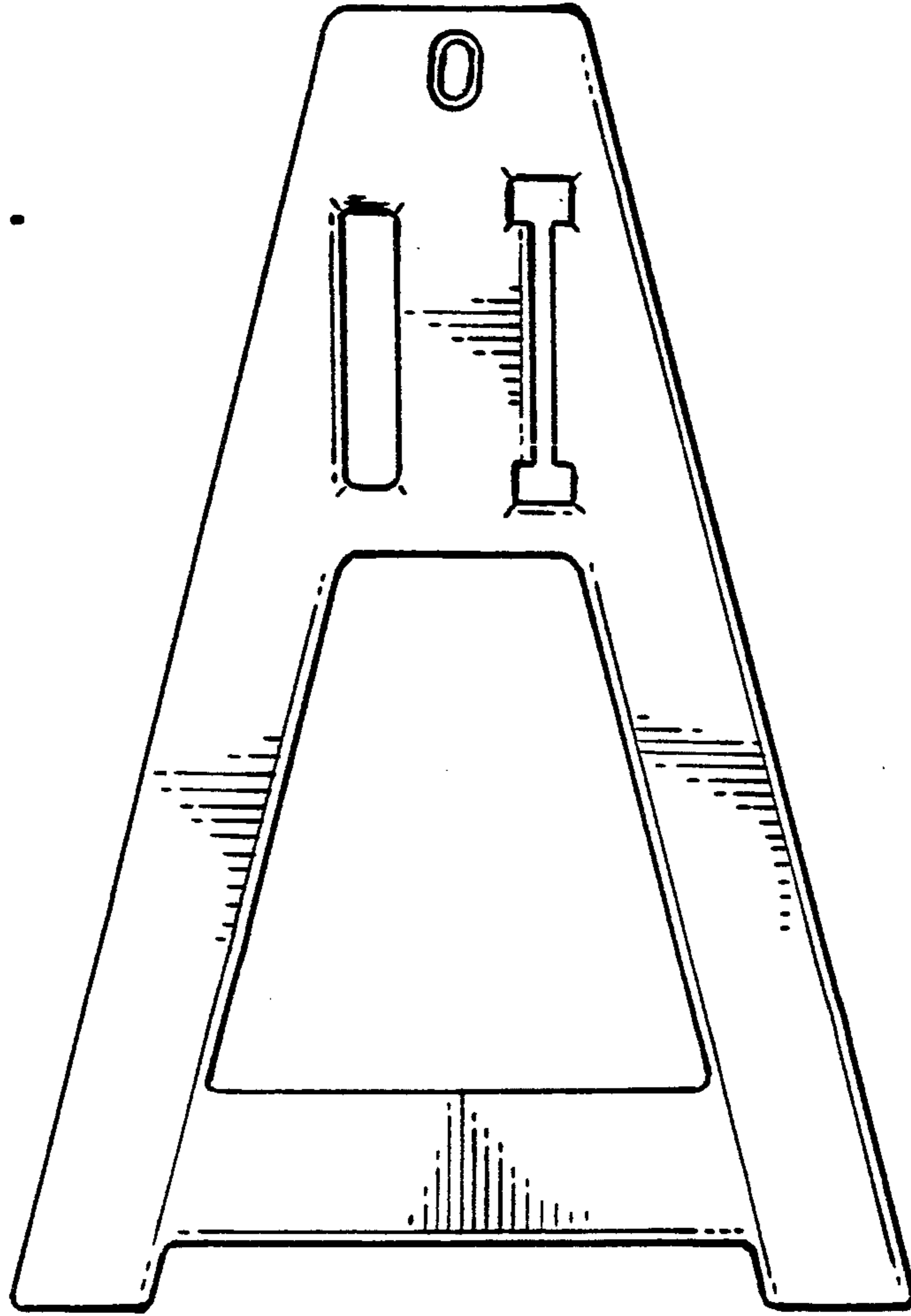

FIG. 5.

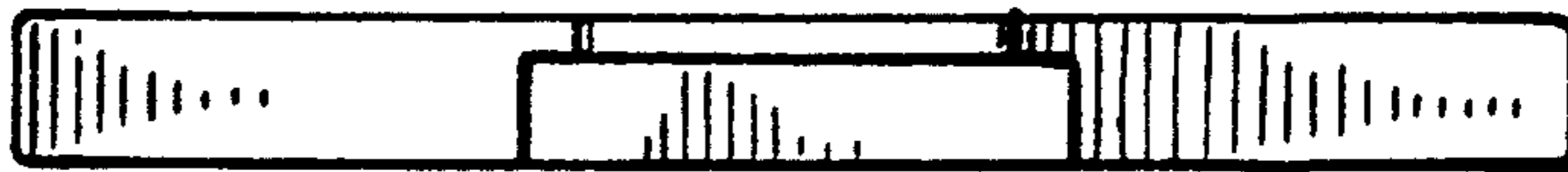

FIG. 6.

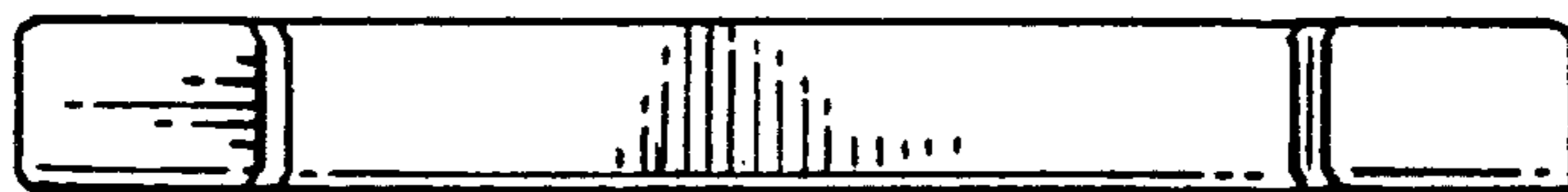

FIG. 7.

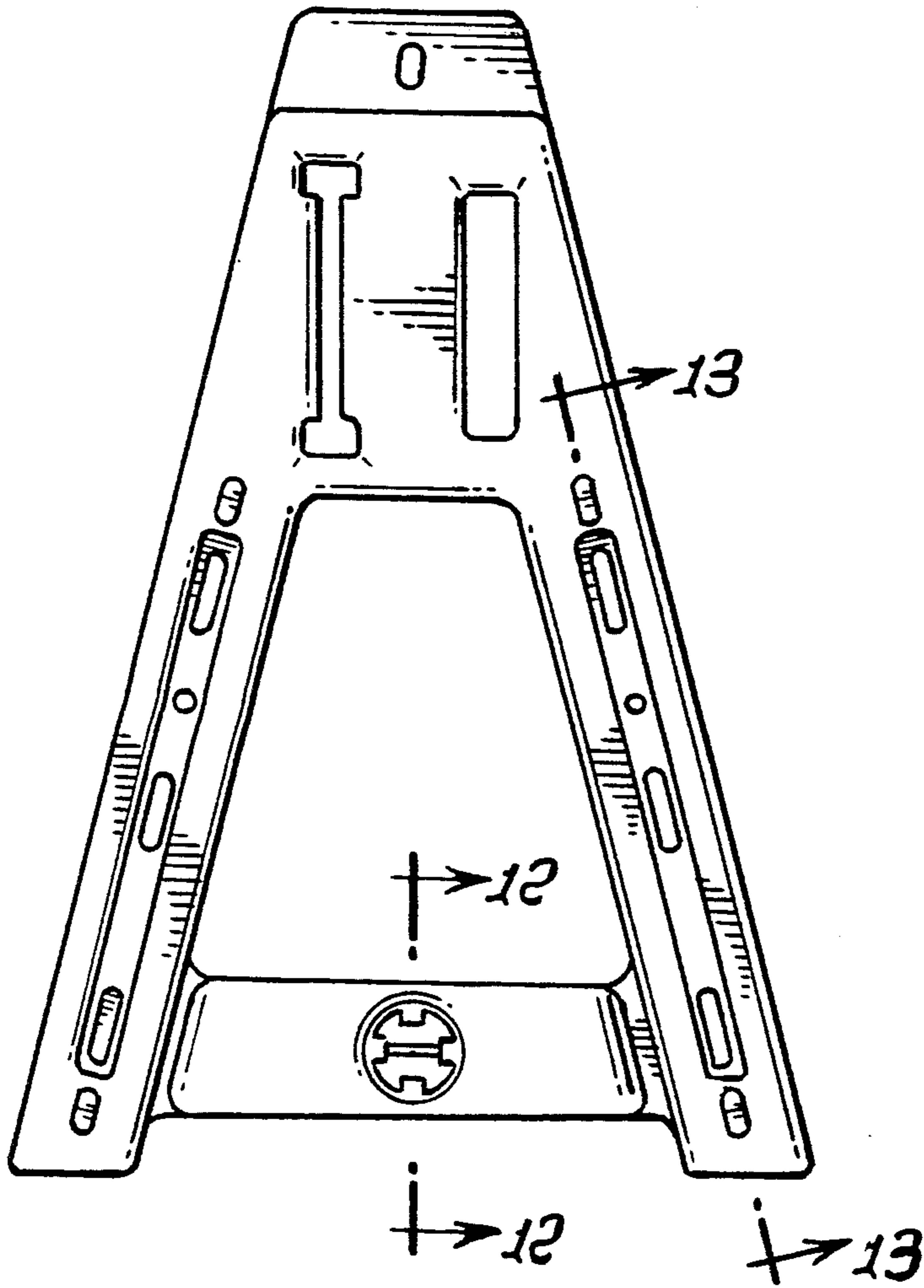

FIG. 8.



FIG. 9.

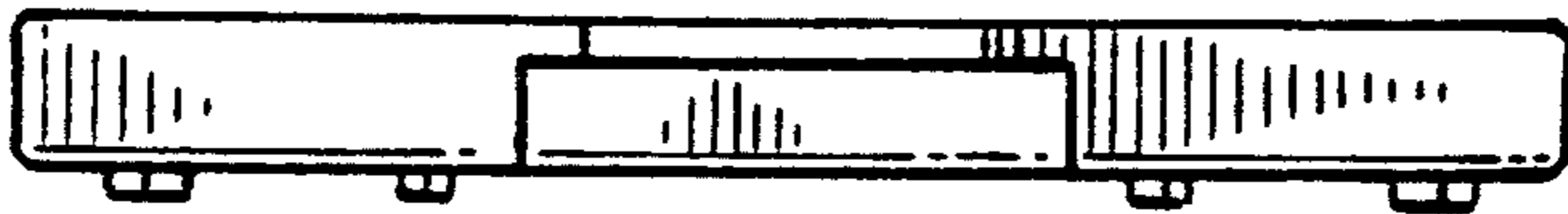

FIG. 10.

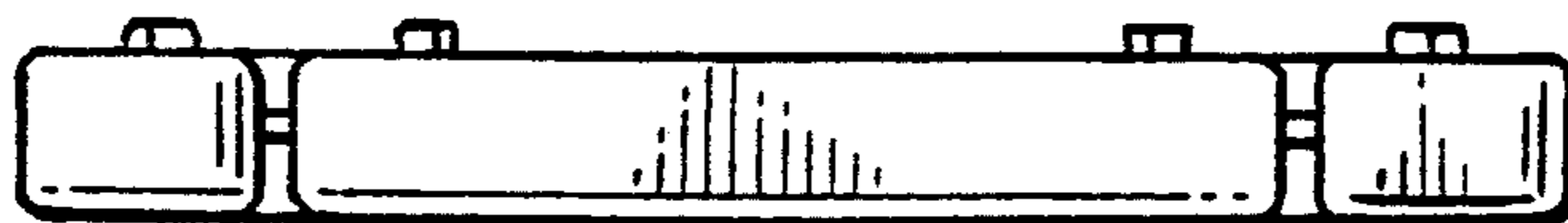

FIG. 11.

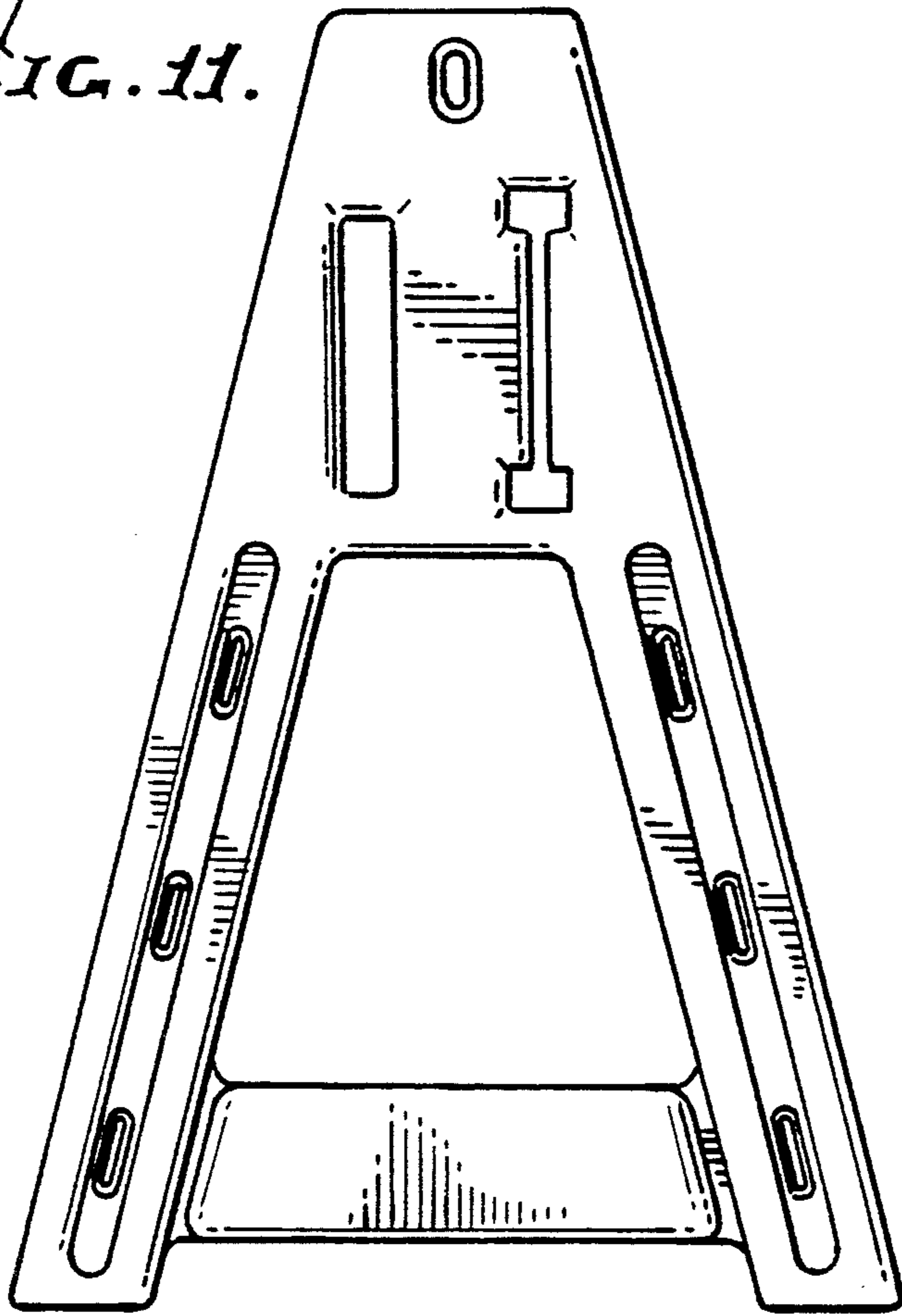

FIG. 13.

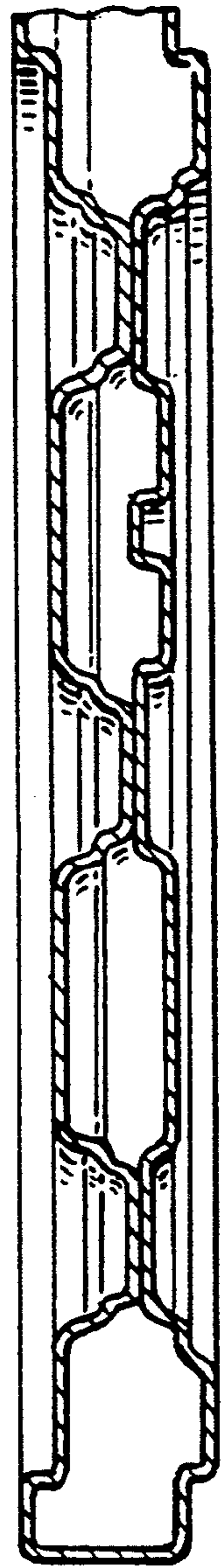

FIG. 12.

