



US00D327456S

United States Patent [19]

[11] Patent Number: Des. 327,456

Sacco et al.

[45] Date of Patent: ** Jun. 30, 1992

[54] TRUCK CAB BODY

[75] Inventors: **Bruno Sacco; Joseph Gallitzendörfer**, both of Sindelfingen; **Peter Pfeiffer**, Böblingen; **Gerhard Honer**, Weil der Stadt; **Klaus Kallenbach**, Stuttgart, all of Fed. Rep. of Germany

[73] Assignee: **Daimler-Benz Aktiengesellschaft**, Fed. Rep. of Germany

[**] Term: **14 Years**

[21] Appl. No.: **388,911**

[22] Filed: **Aug. 3, 1989**

[30] Foreign Application Priority Data

Feb. 6, 1989 [DE] Fed. Rep. of Germany ... M8900865

Feb. 6, 1989 [DE] Fed. Rep. of Germany ... M8900866

[52] U.S. Cl. **D12/96**

[58] Field of Search D12/96, 98; 296/183, 296/190; 180/89.1

[56] References Cited

U.S. PATENT DOCUMENTS

D. 191.607 10/1961 Rutman D12/96

D. 239.823 5/1976 Juillet D12/96

D. 302.257 7/1989 Breitschwerdt et al. D12/96

D. 307.878 5/1990 Lechner D12/96

Primary Examiner—James M. Gandy

Attorney, Agent, or Firm—Evenson, Wands, Edwards, Lenahan & McKeown

[57] CLAIM

The ornamental design for a truck cab body, as shown and described.

DESCRIPTION

FIG. 1 is a front end elevation view of a first embodiment of a truck cab body embodying our novel design; FIG. 2 is a rear end elevation view of the first embodiment thereof; FIG. 3 is a left side elevation view of the first embodiment thereof; FIG. 4 is a right side elevation view of the first embodiment thereof;

FIG. 5 is a left side perspective view, taken from the front end of the first embodiment thereof;

FIG. 6 is a right side perspective view, taken from the front end of the first embodiment thereof;

FIG. 7 is a left side perspective view, taken from the rear end of the first embodiment thereof;

FIG. 8 is a right side perspective view, taken from the rear end of the first embodiment thereof;

FIG. 9 is a top plan view of the first embodiment thereof;

FIG. 10 is a front end elevation view of a second embodiment of a truck cab body embodying our novel design;

FIG. 11 is a rear end elevation view of the second embodiment thereof;

FIG. 12 is a left side elevation view of the second embodiment thereof;

FIG. 13 is a right side elevation view of the second embodiment thereof;

FIG. 14 is a left side perspective view, taken from the front end of the second embodiment thereof;

FIG. 15 is a right side perspective view, taken from the front end of the second embodiment thereof;

FIG. 16 is a left side perspective view, taken from the rear end of the second embodiment thereof;

FIG. 17 is a right side perspective view, taken from the rear end of the second embodiment thereof;

FIG. 18 is a top plan view of the second embodiment thereof;

FIG. 19 is a front end elevation view of a third embodiment of a truck cab body embodying our novel design;

FIG. 20 is a rear end elevation view of the third embodiment thereof;

FIG. 21 is a left side elevation view of the third embodiment thereof;

FIG. 22 is a right side elevation view of the third embodiment thereof;

FIG. 23 is a left side perspective view, taken from the front end of the third embodiment thereof;

FIG. 24 is a right side perspective view, taken from the front end of the third embodiment thereof;

FIG. 25 is a left side perspective view, taken from the rear end of the third embodiment thereof;

FIG. 26 is a right side perspective view, taken from the rear end of the third embodiment thereof;

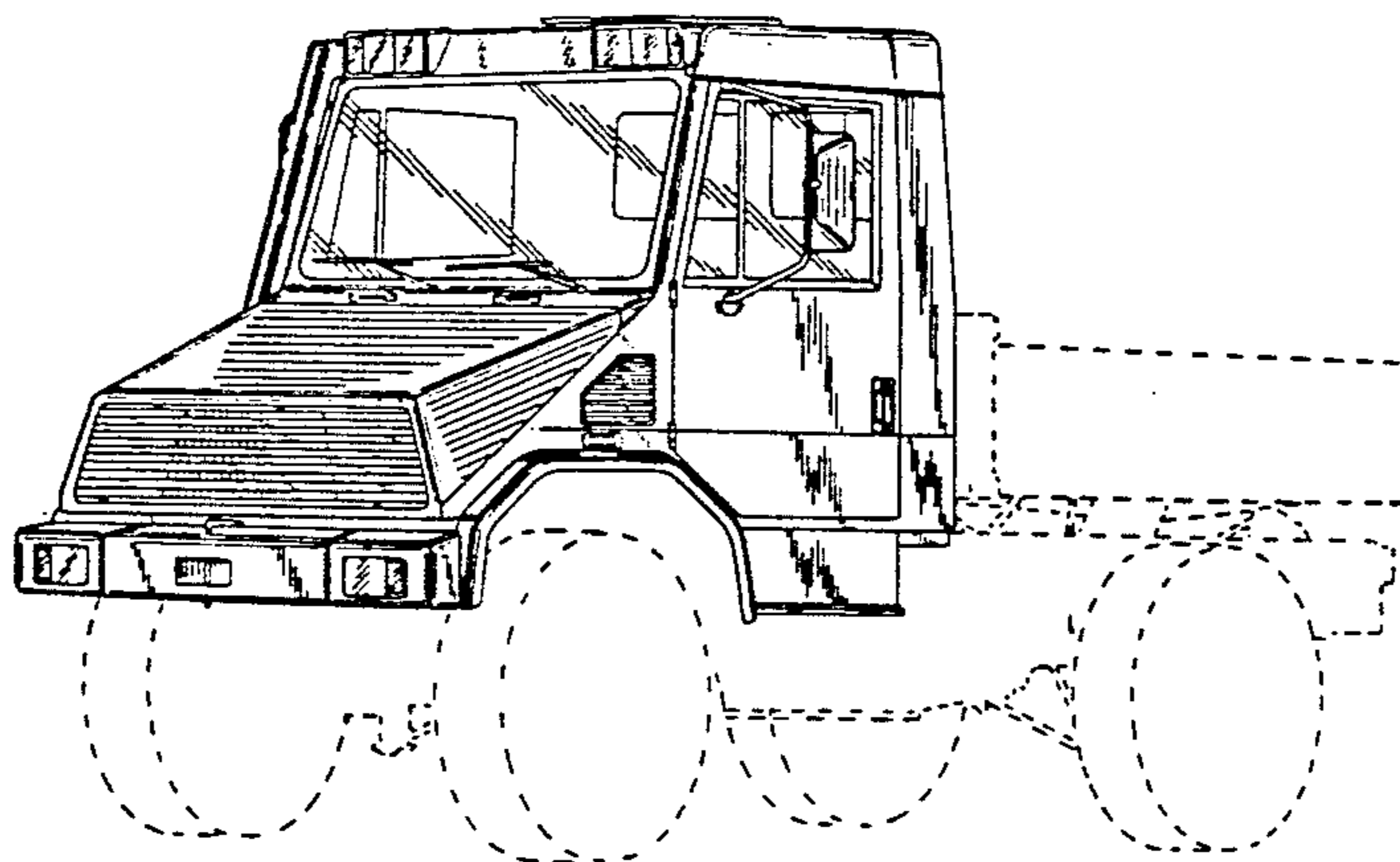

FIG. 27 is a top plan view of the third embodiment thereof;

FIG. 28 is a front end elevation view of a fourth embodiment of a truck cab body embodying our novel design;

FIG. 29 is a rear end elevation view of the fourth embodiment thereof;

FIG. 30 is a left side elevation view of the fourth embodiment thereof;

FIG. 31 is a right side elevation view of the fourth embodiment thereof;

FIG. 32 is a left side perspective view taken from the front end of the fourth embodiment thereof;

FIG. 33 is a right side perspective view, taken from the front end of the fourth embodiment thereof;

FIG. 34 is a left side perspective view, taken from the rear end of the fourth embodiment thereof;

FIG. 35 is a right side perspective view, taken from the rear end of the fourth embodiment thereof;

FIG. 36 is a top plan view of the fourth embodiment thereof; and,

FIG. 37 is a fragmentary rear elevation view of all four embodiments thereof showing the complete appearance of the lower portion of the rear panel it being understood that the upper roof portion has been omitted for convenience of illustration.

The broken lines in the drawing are for illustrative purposes only and form no part of the claimed design.

FIG. 1

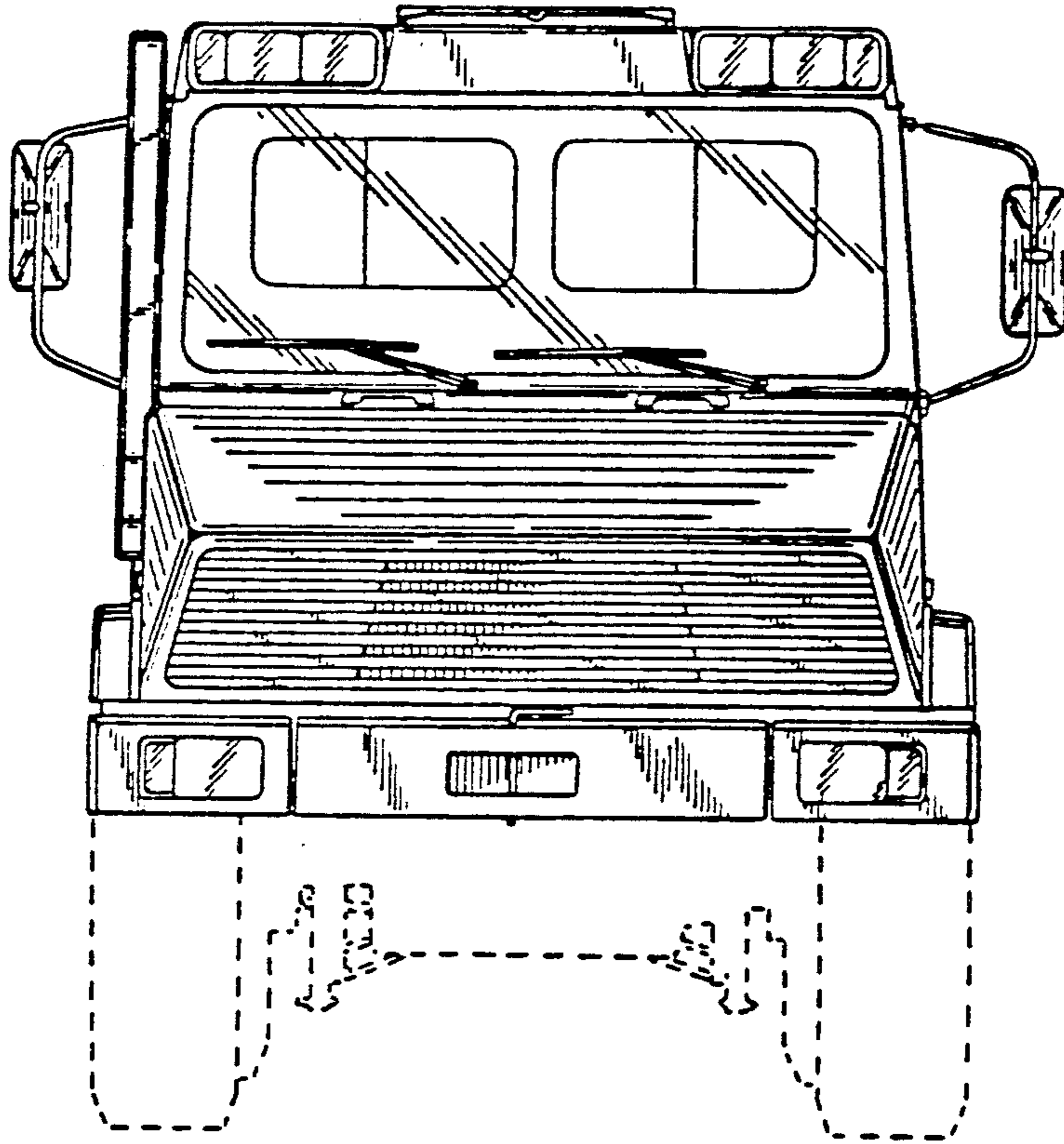

FIG. 2

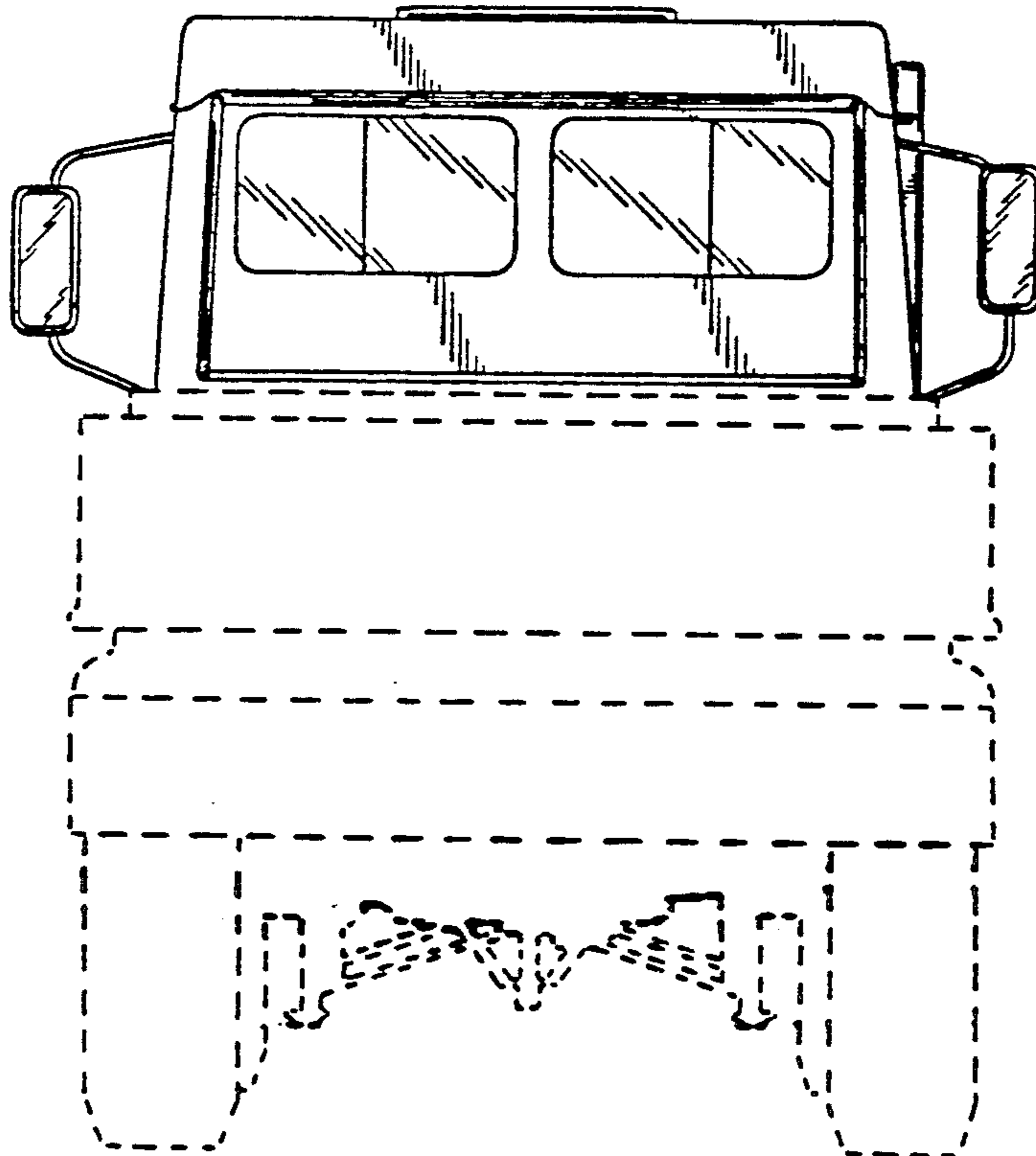

FIG. 3

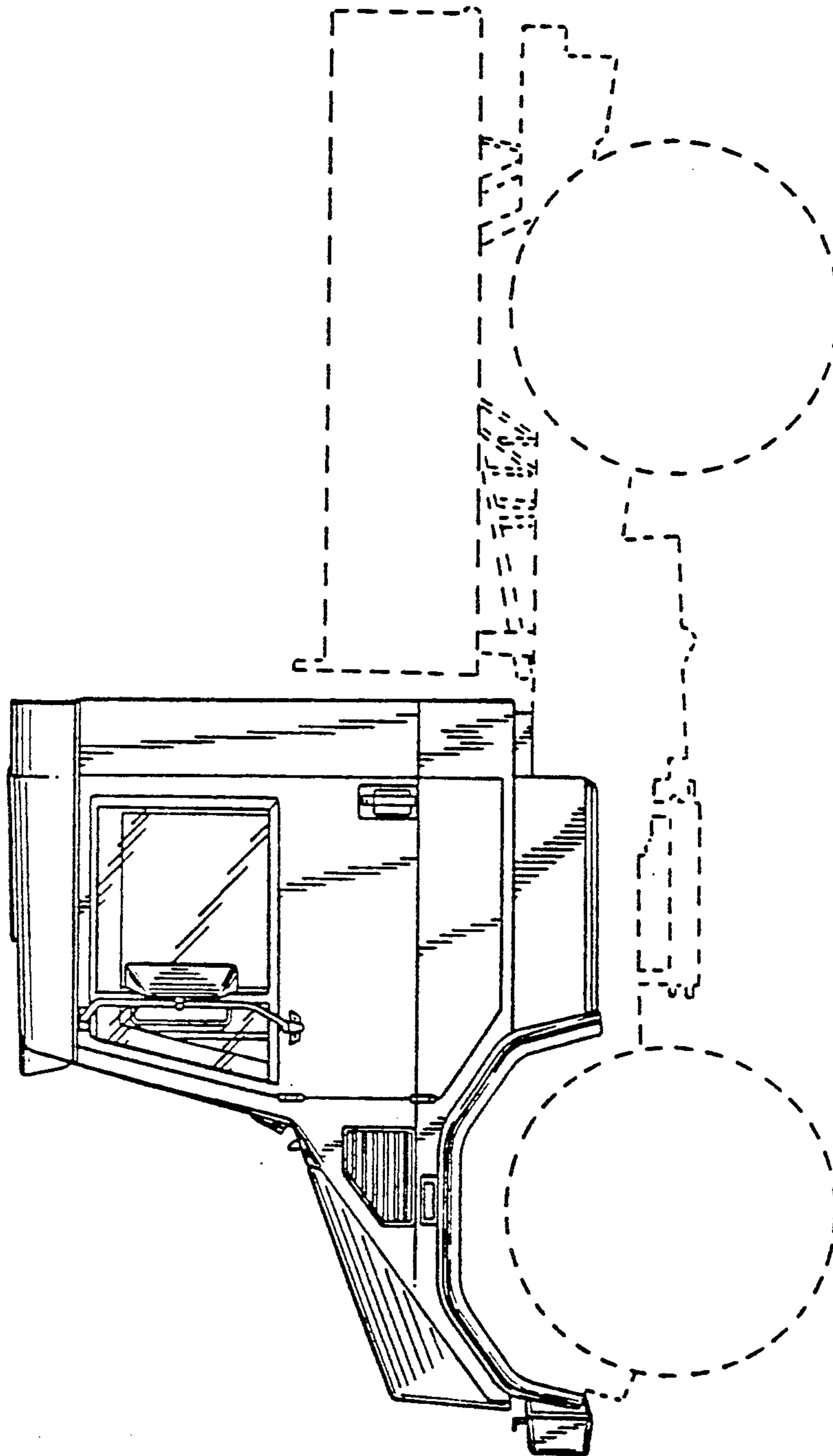

FIG. 4

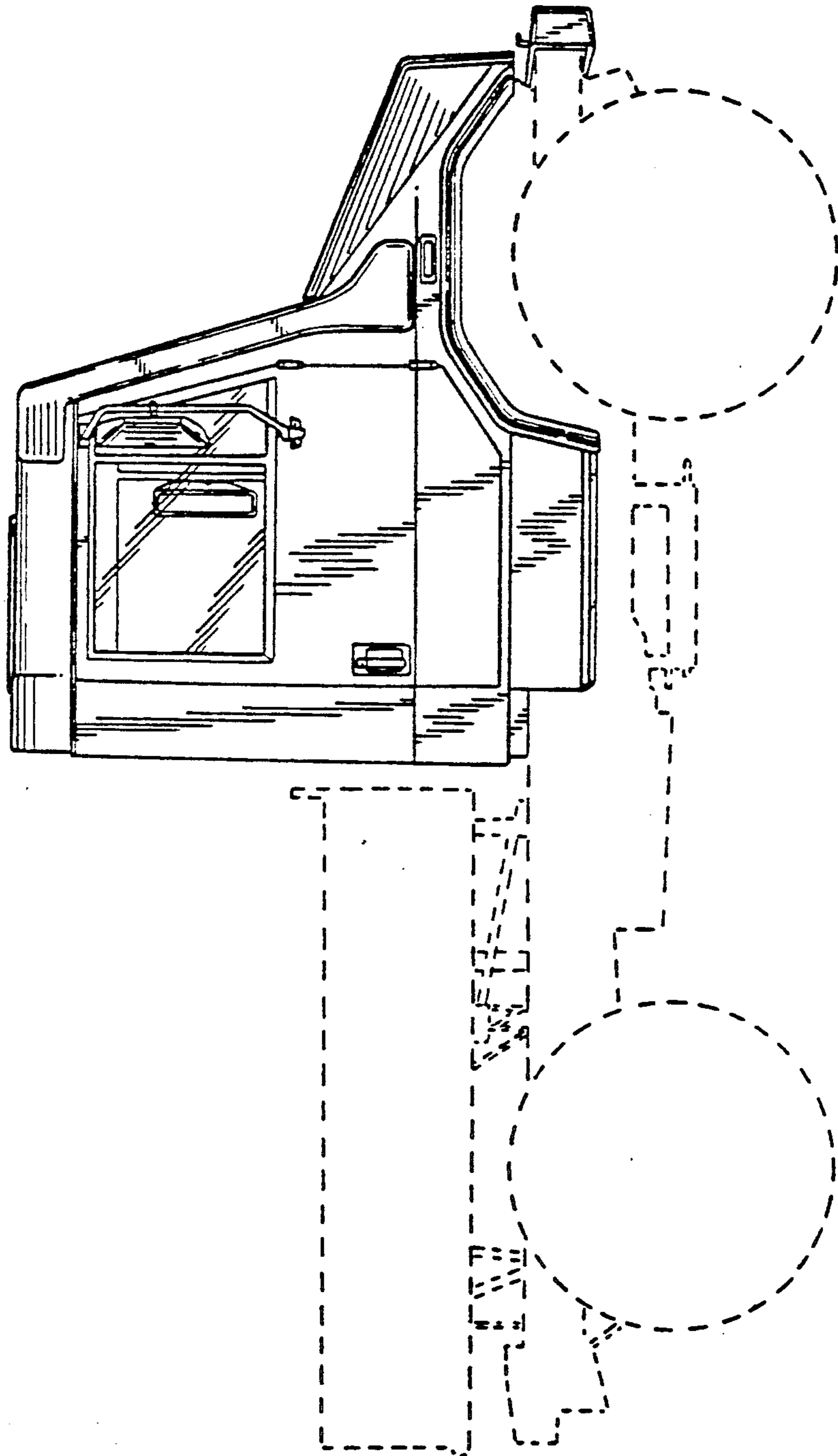

FIG. 5

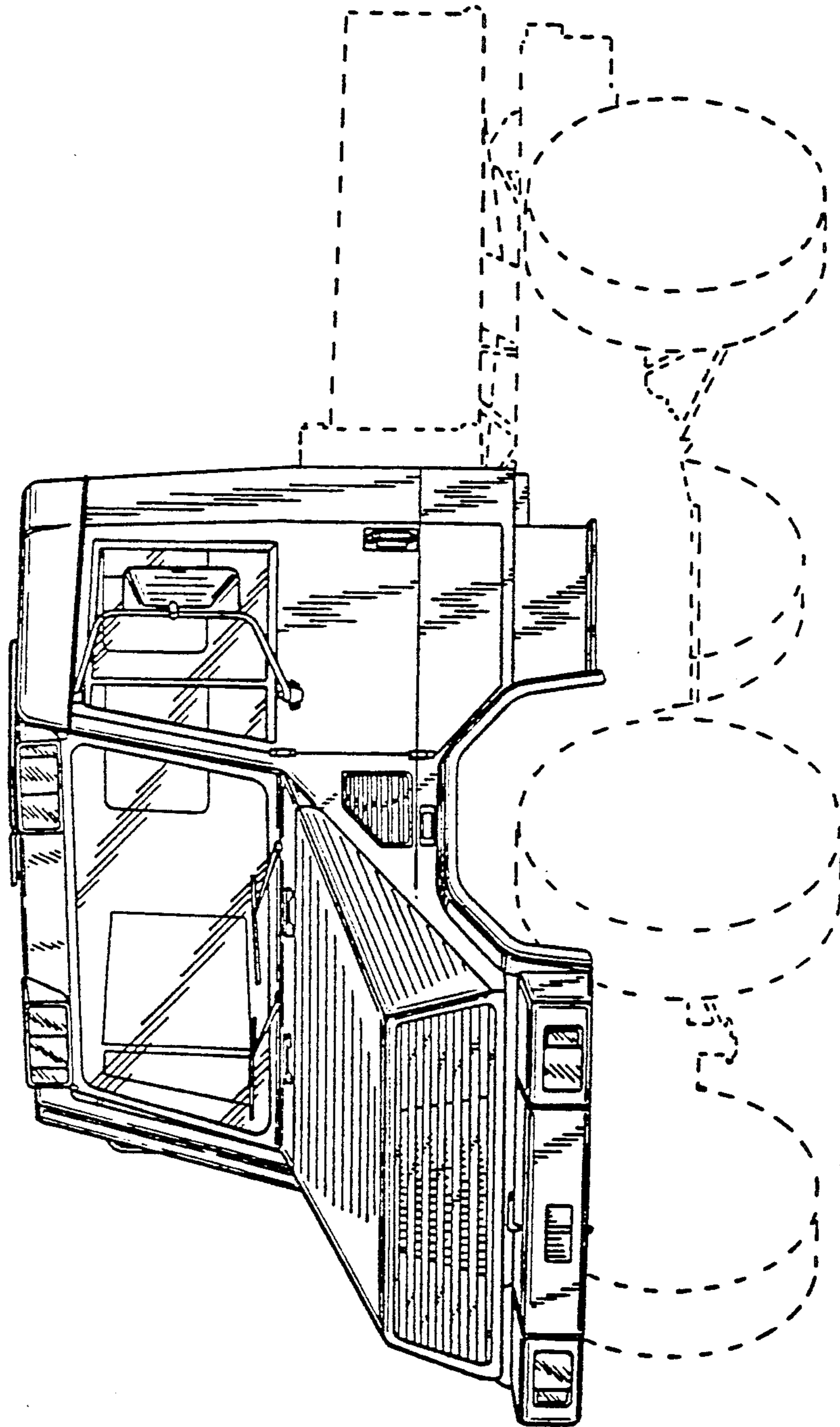

FIG. 6

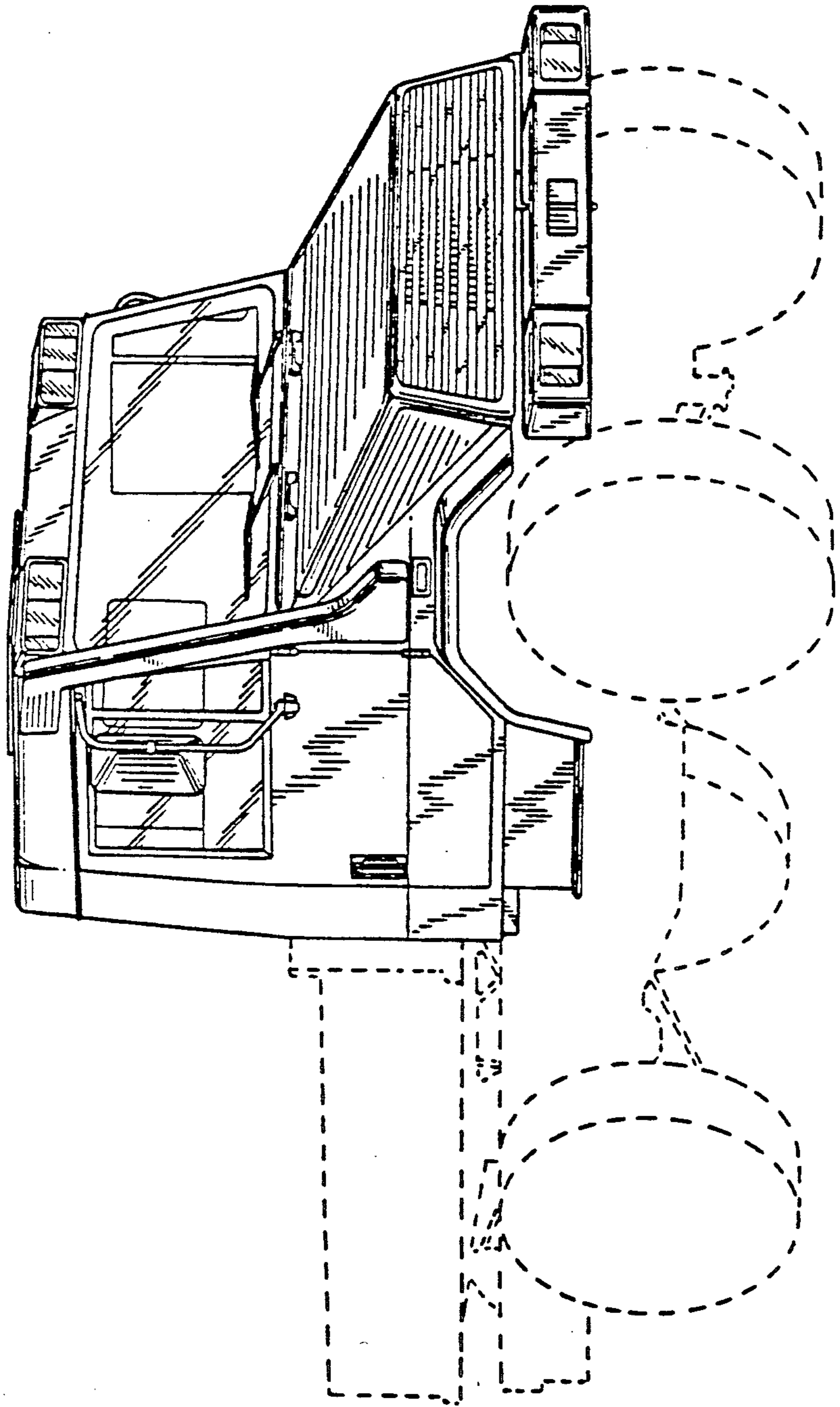

FIG. 7

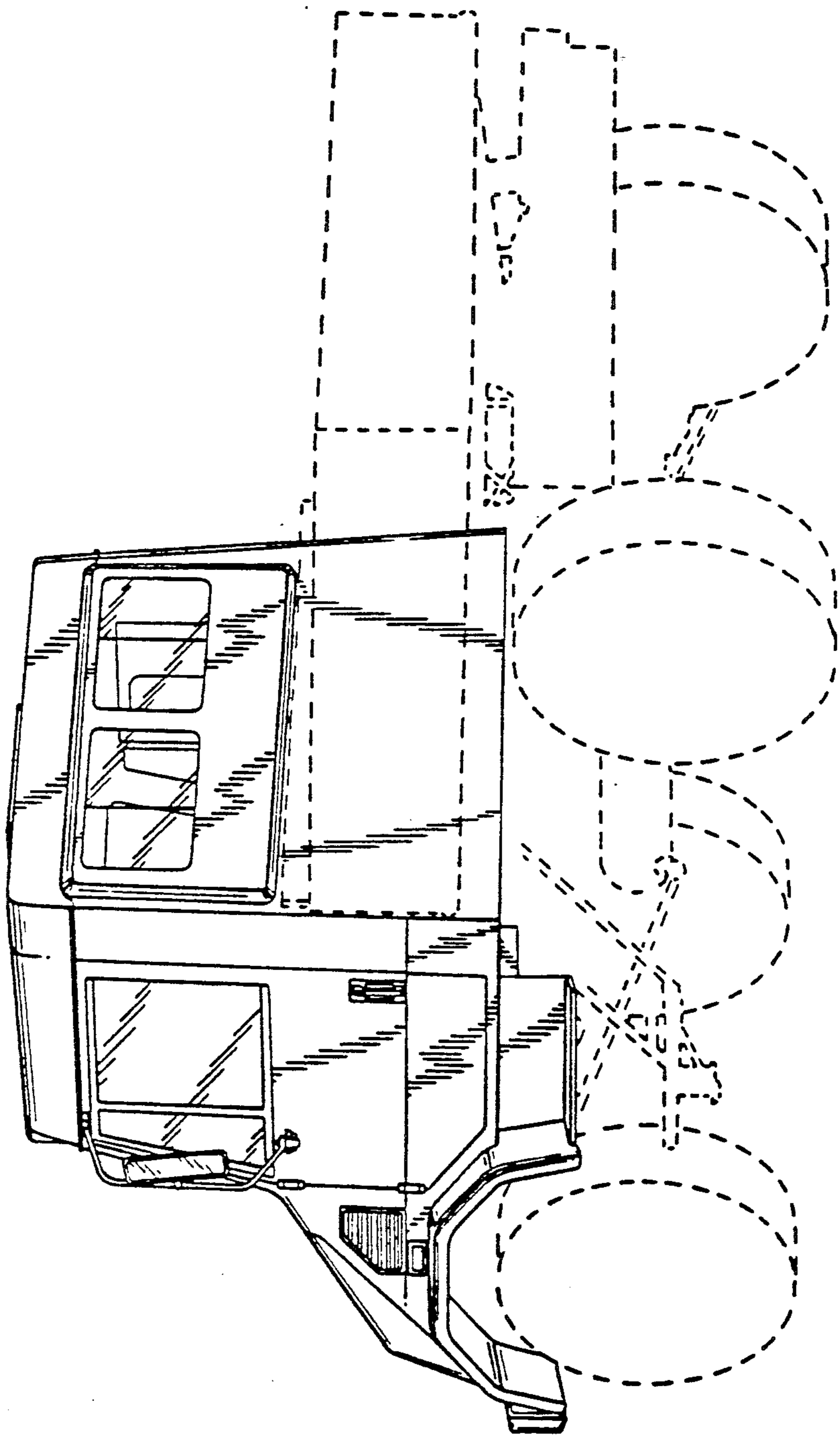

FIG. 8

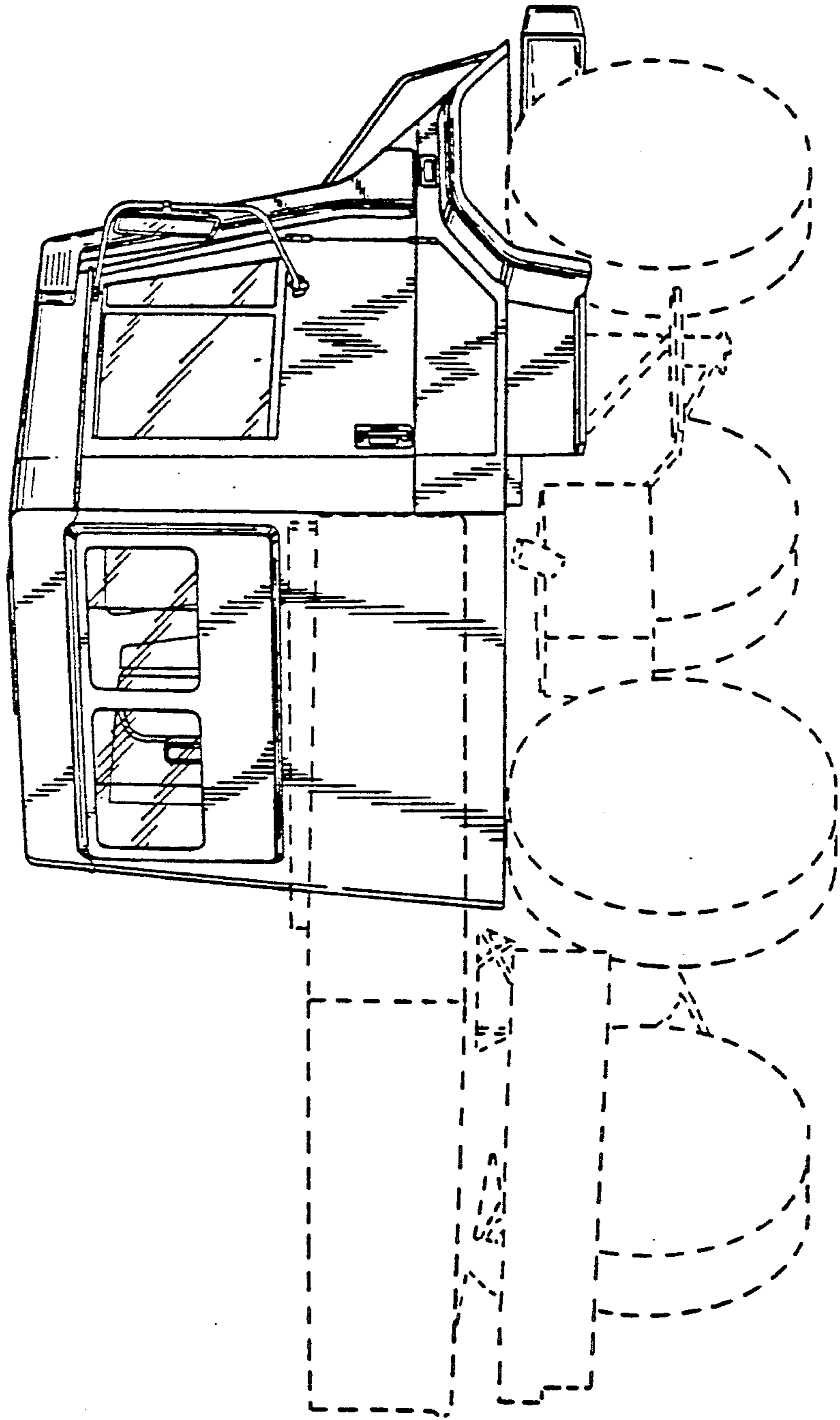

FIG. 9

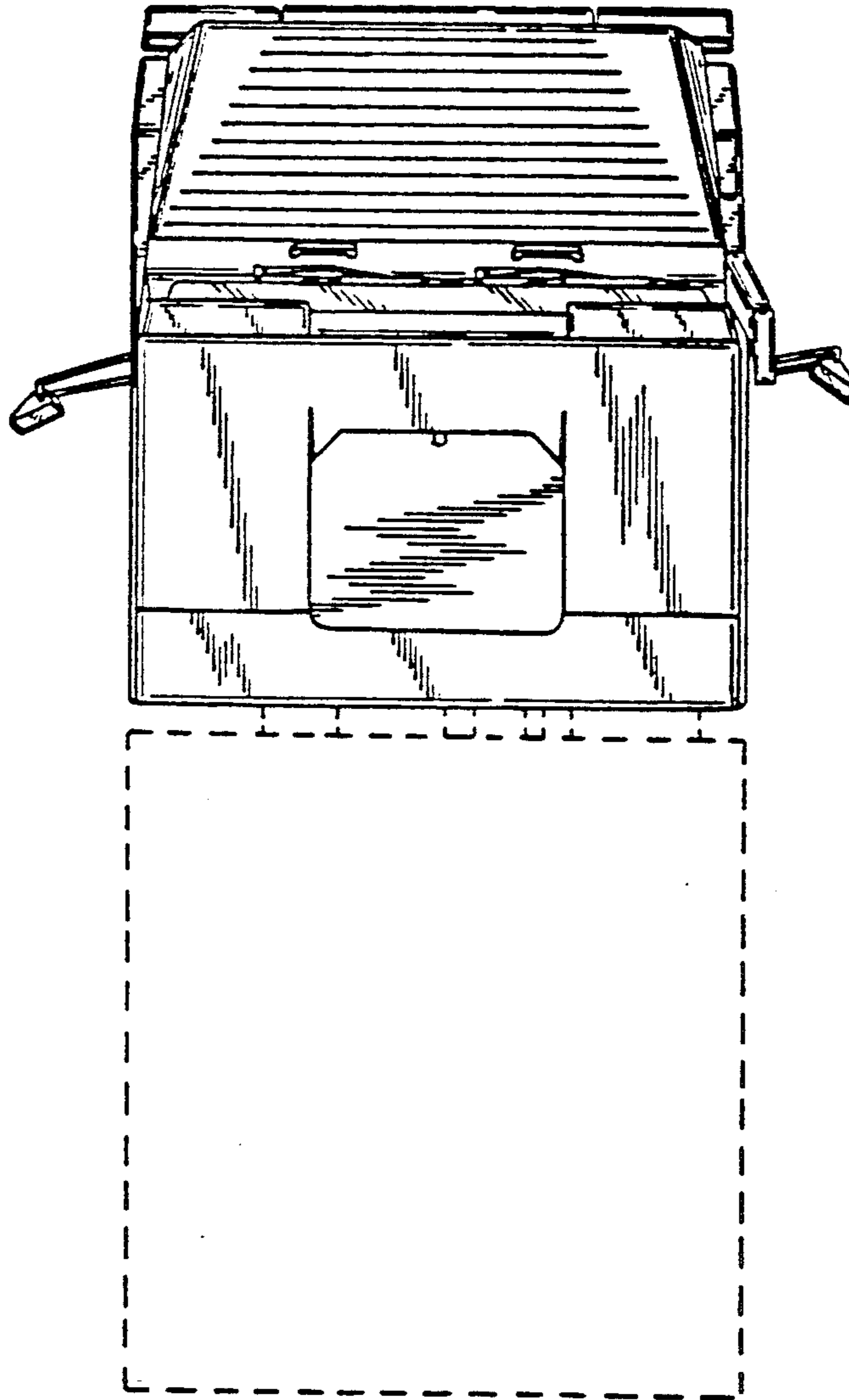

FIG. 10

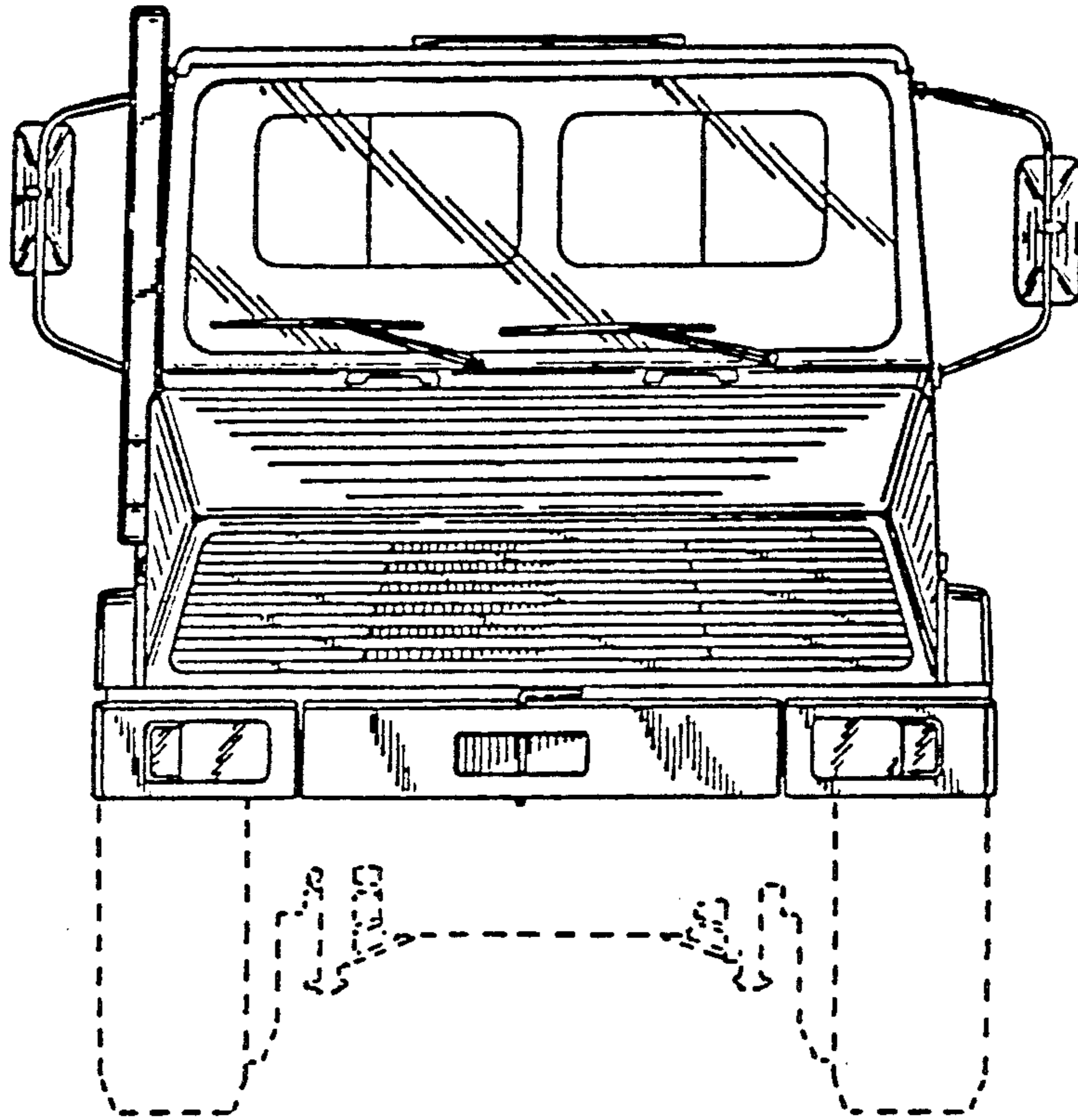

FIG. 11

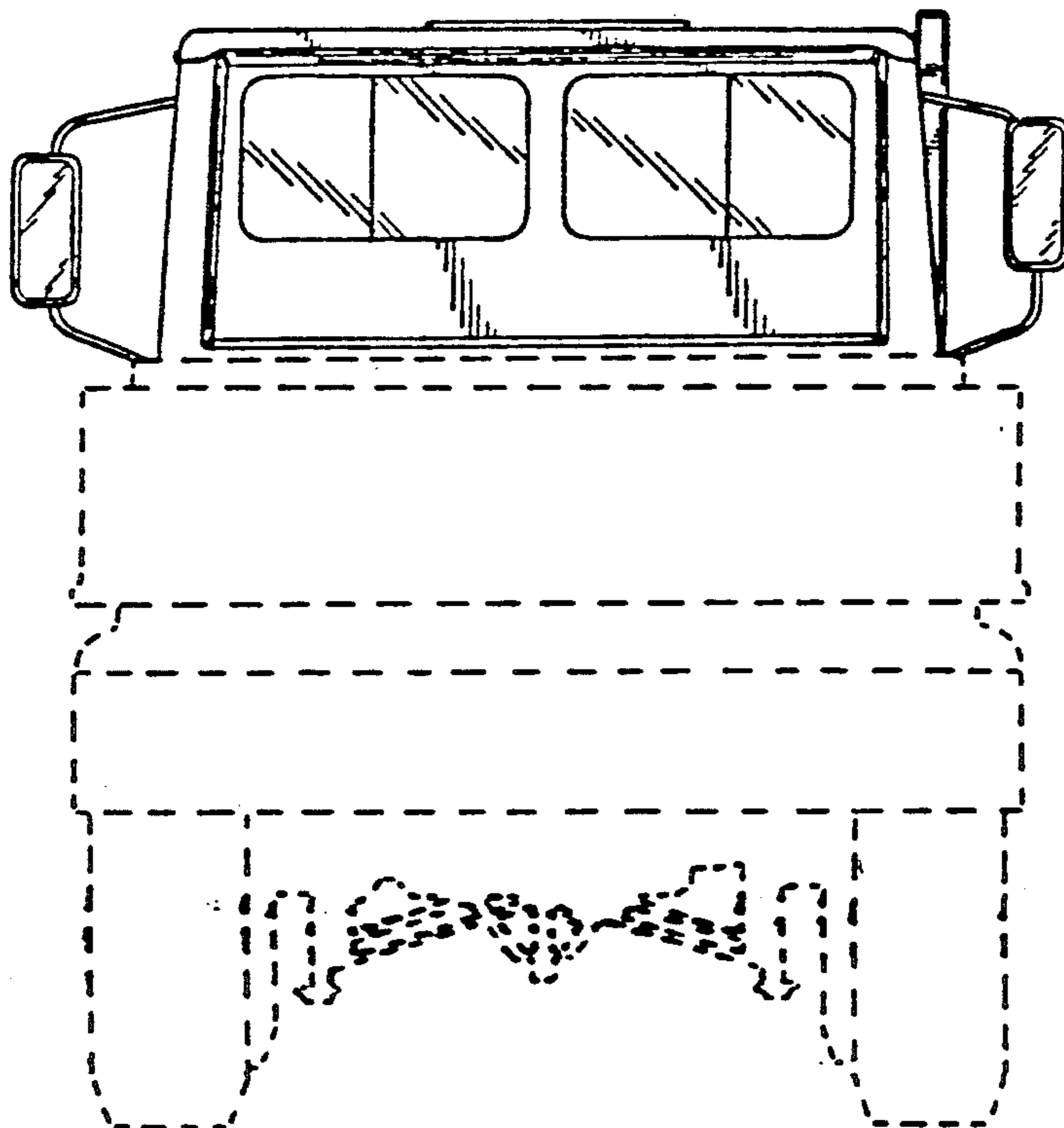

FIG. 12

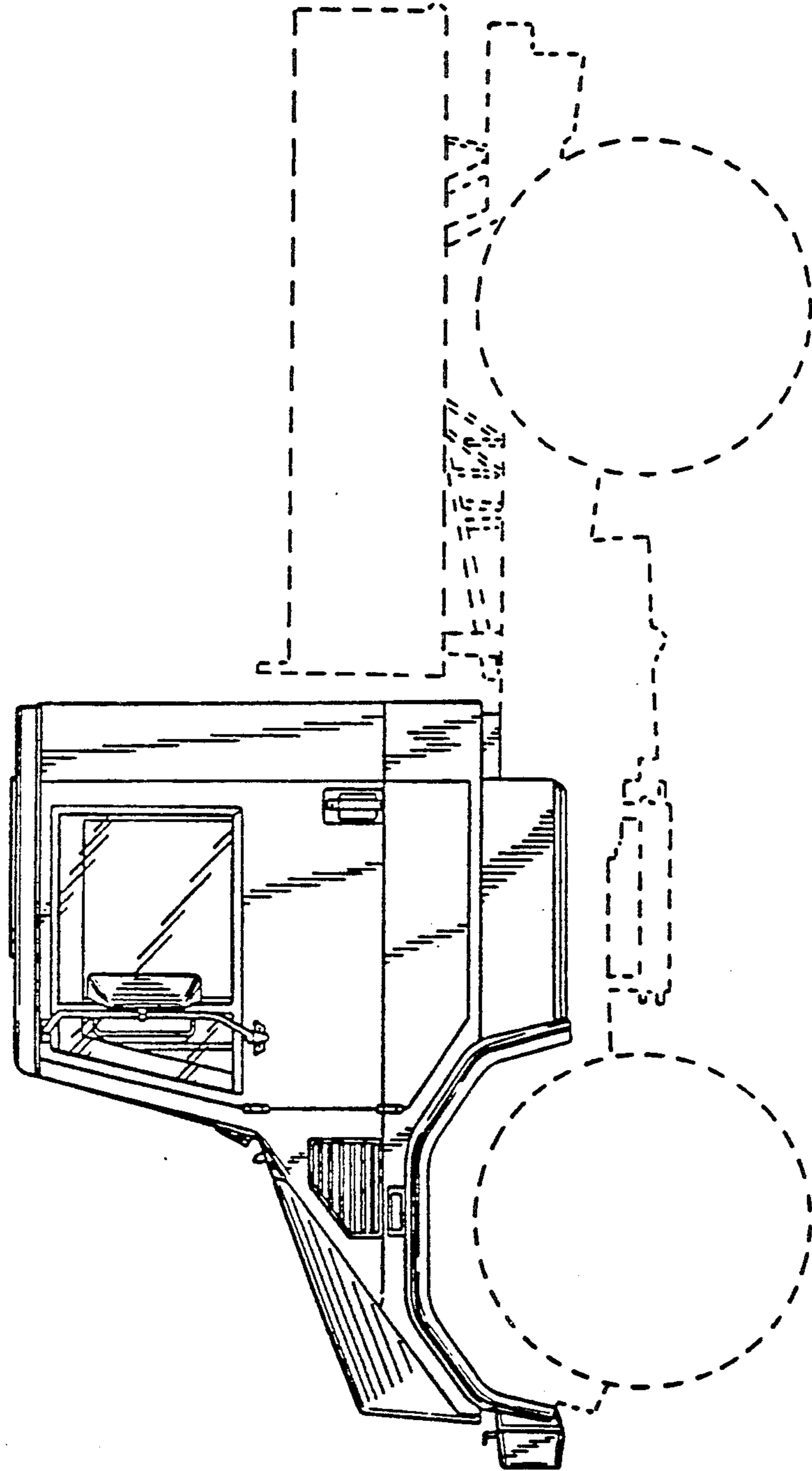

FIG. 13

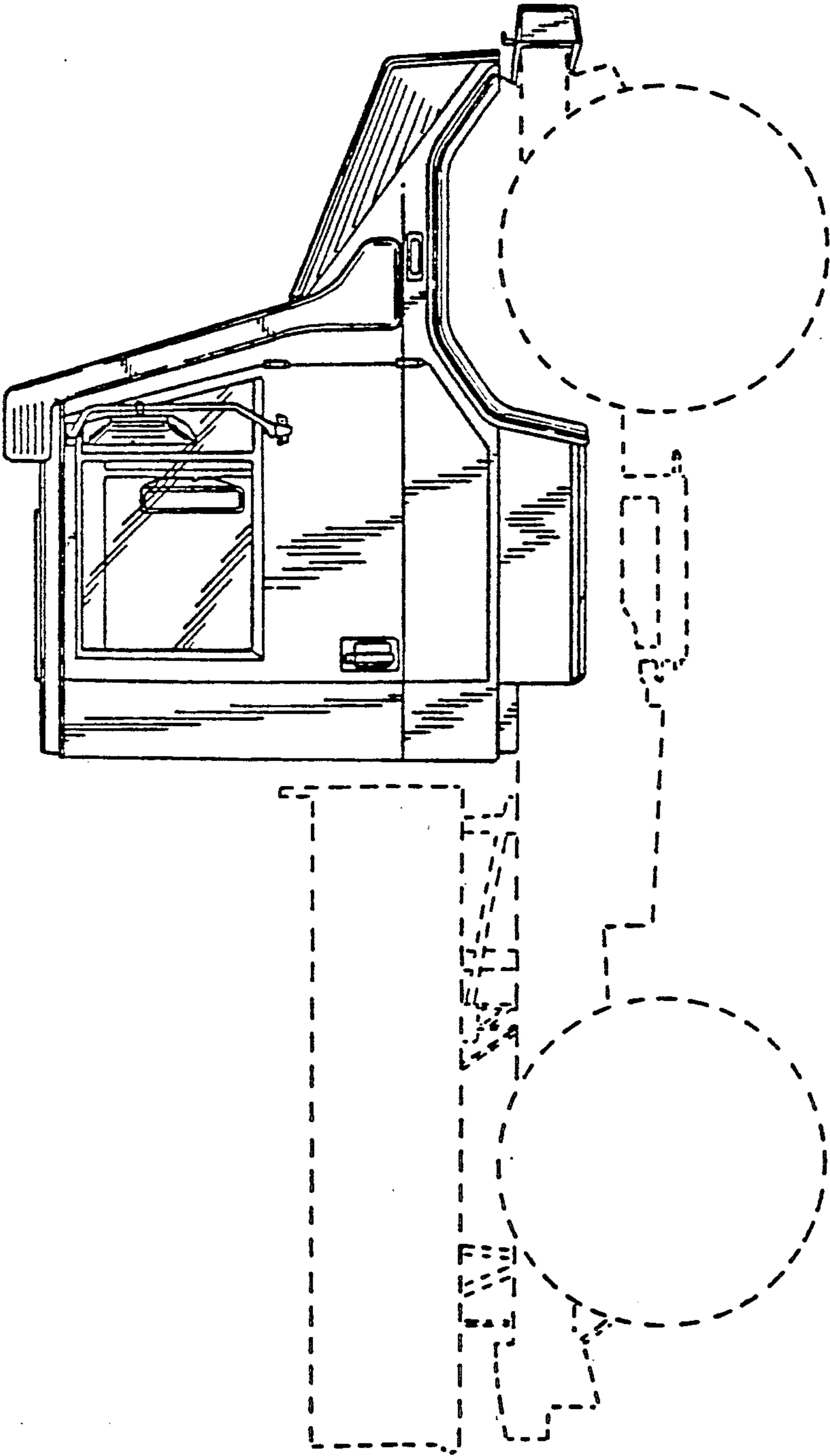

FIG. 14

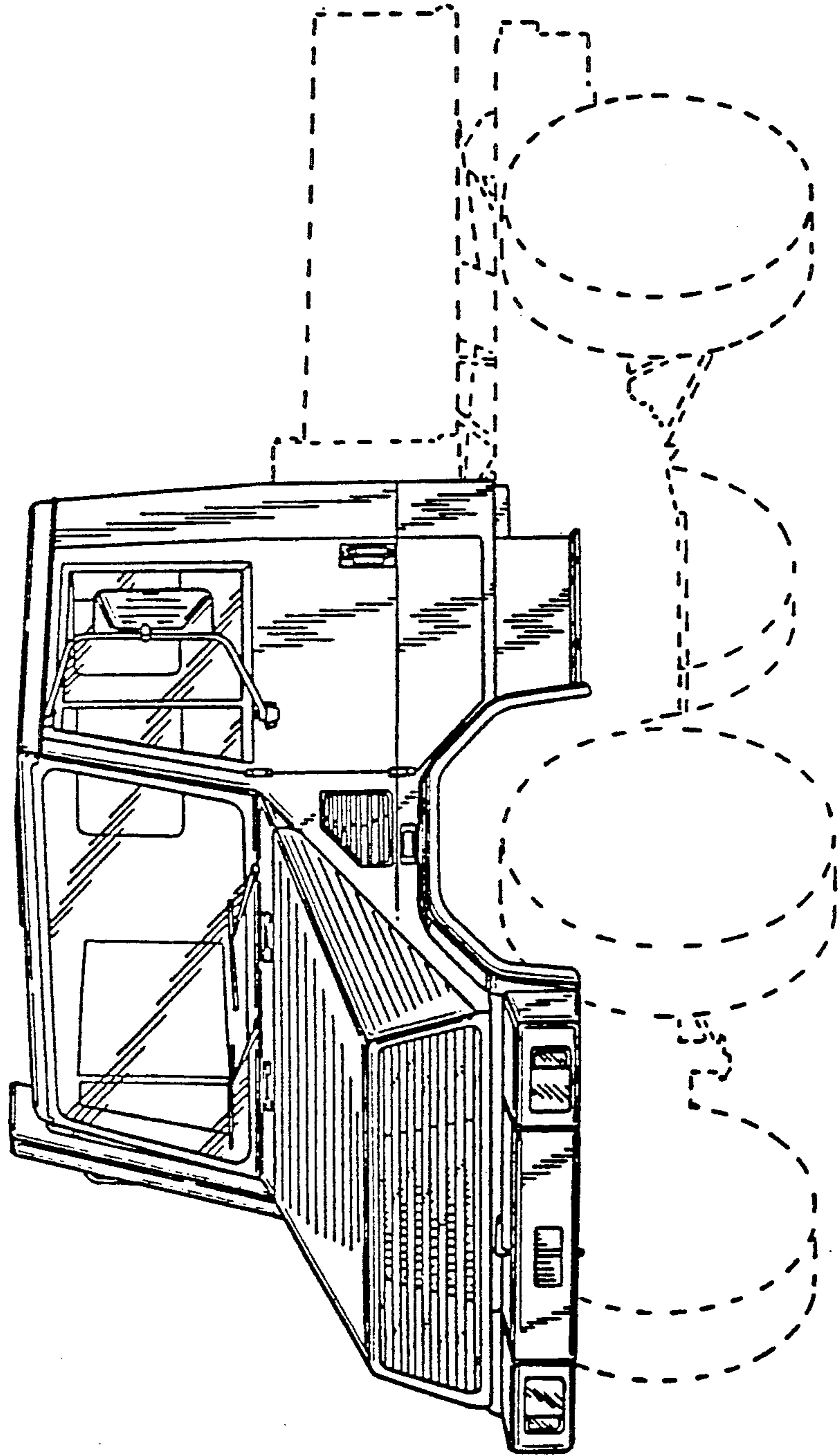

FIG. 15

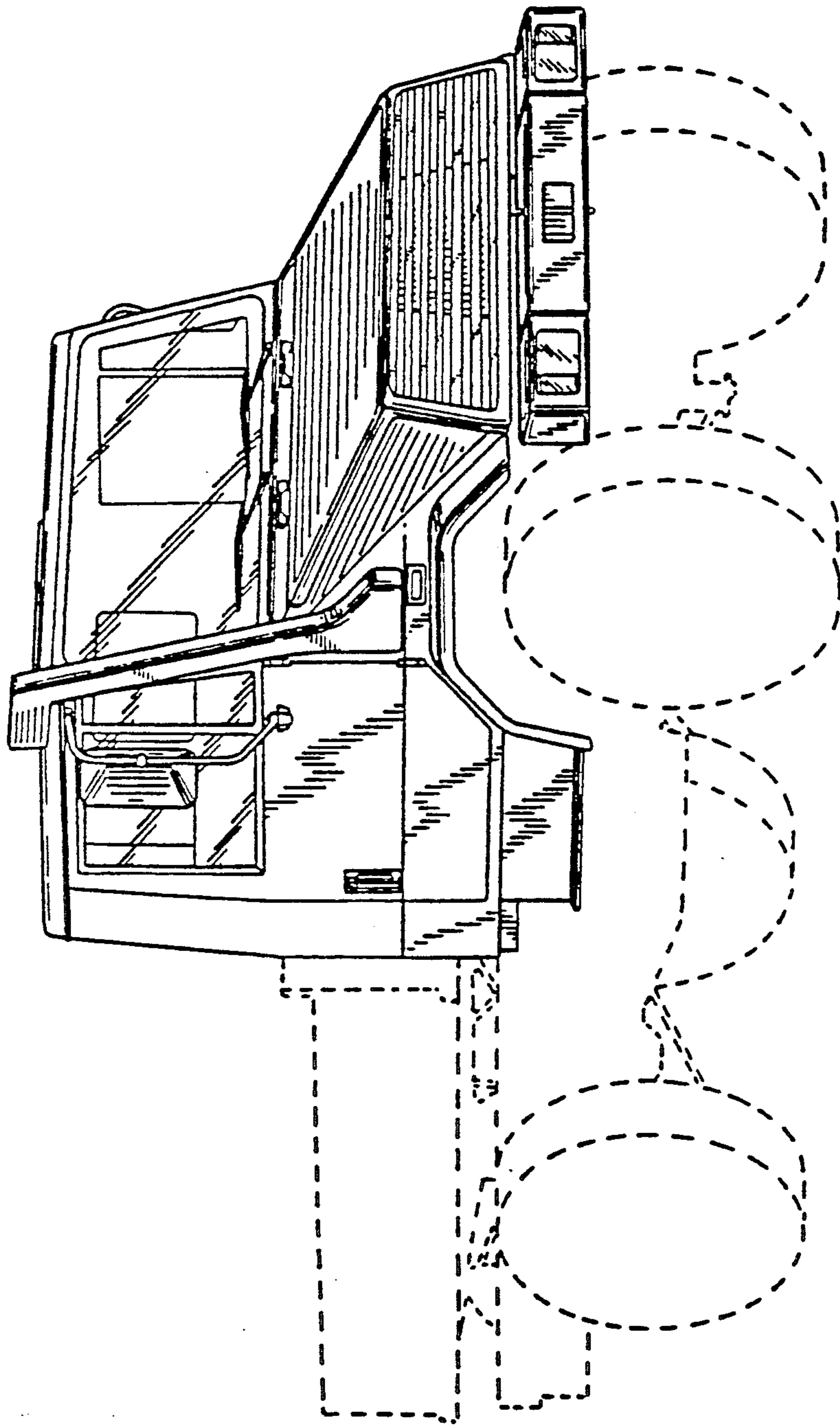

FIG. 16

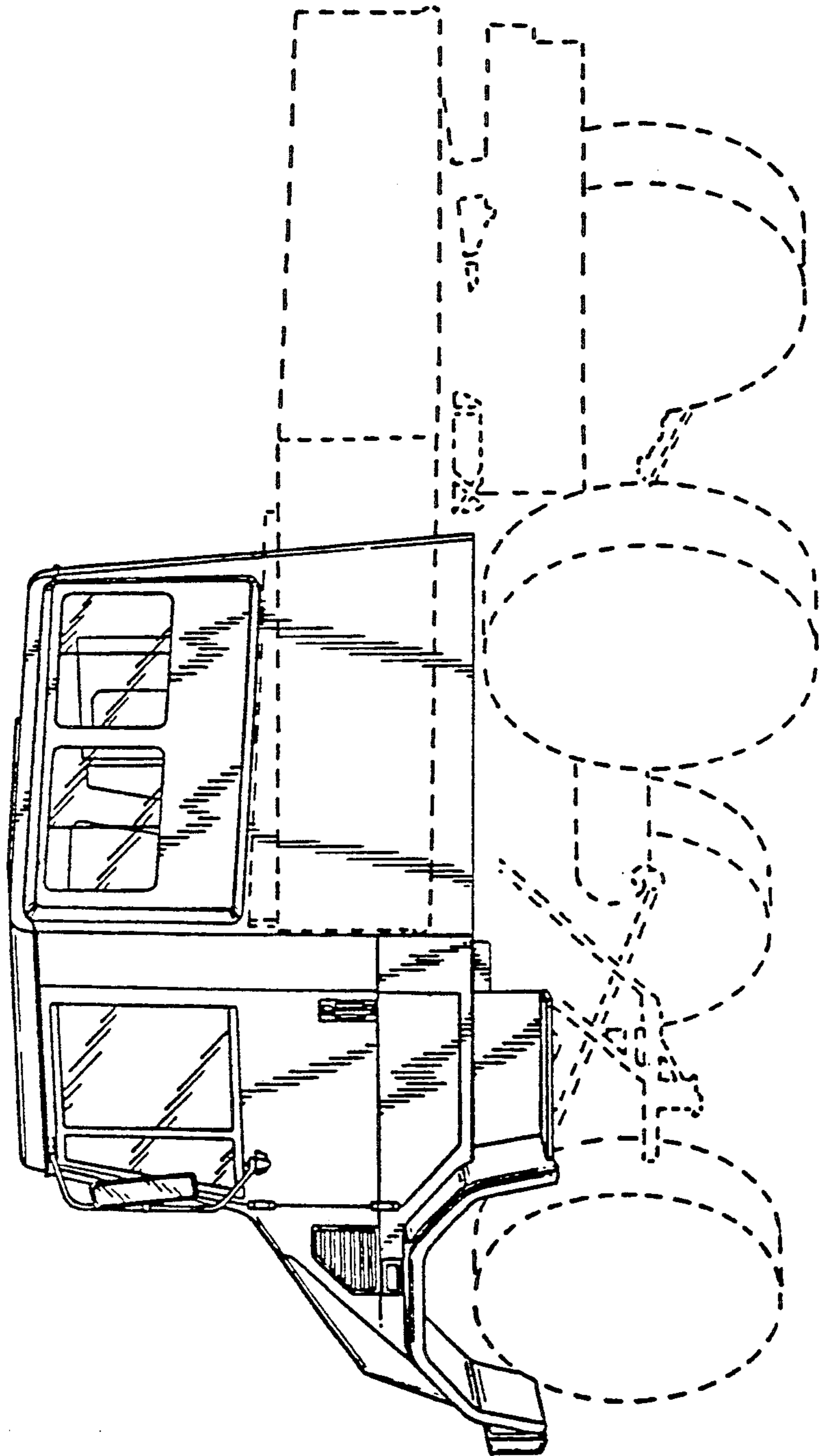

FIG. 17

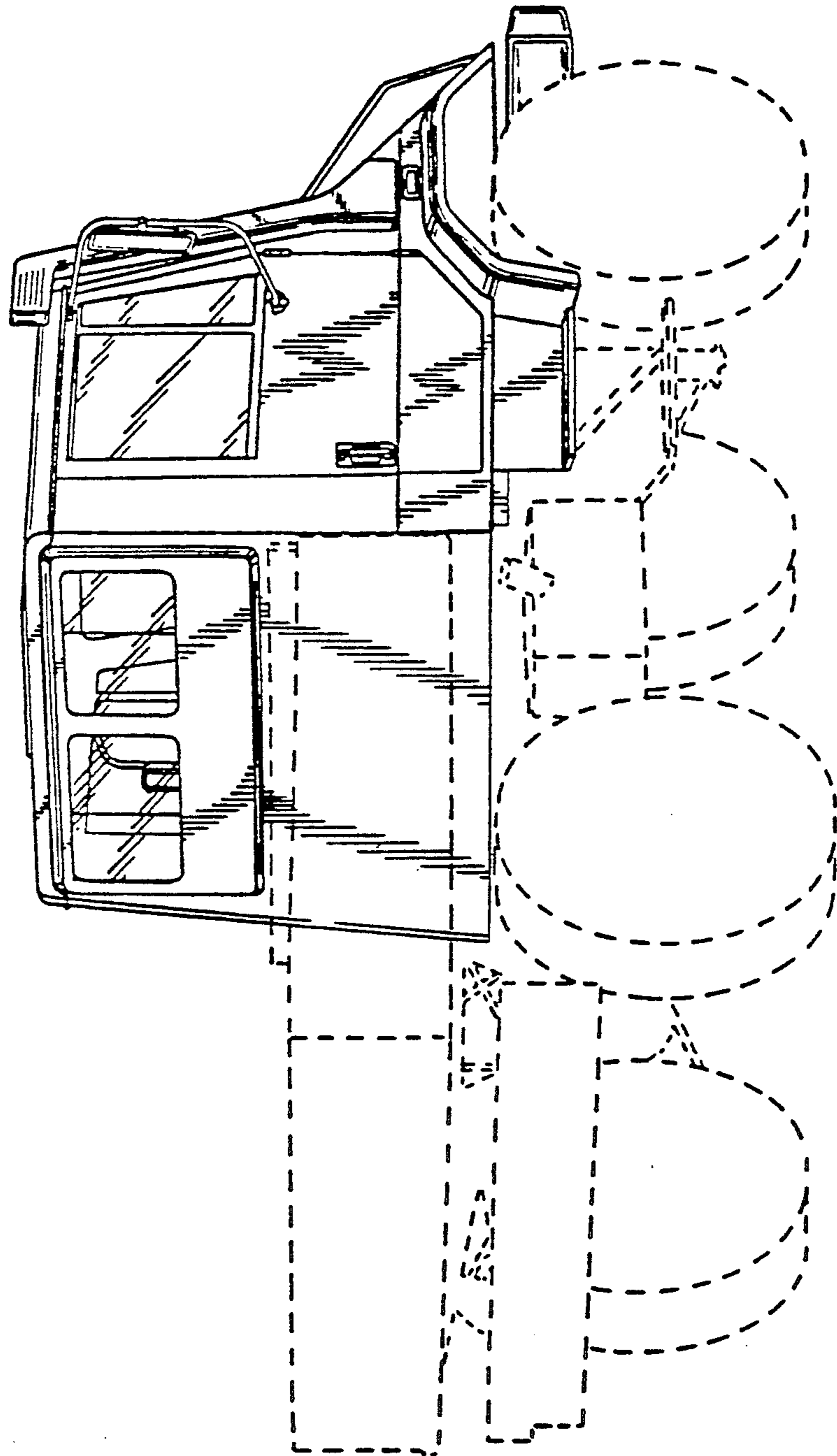

FIG. 18

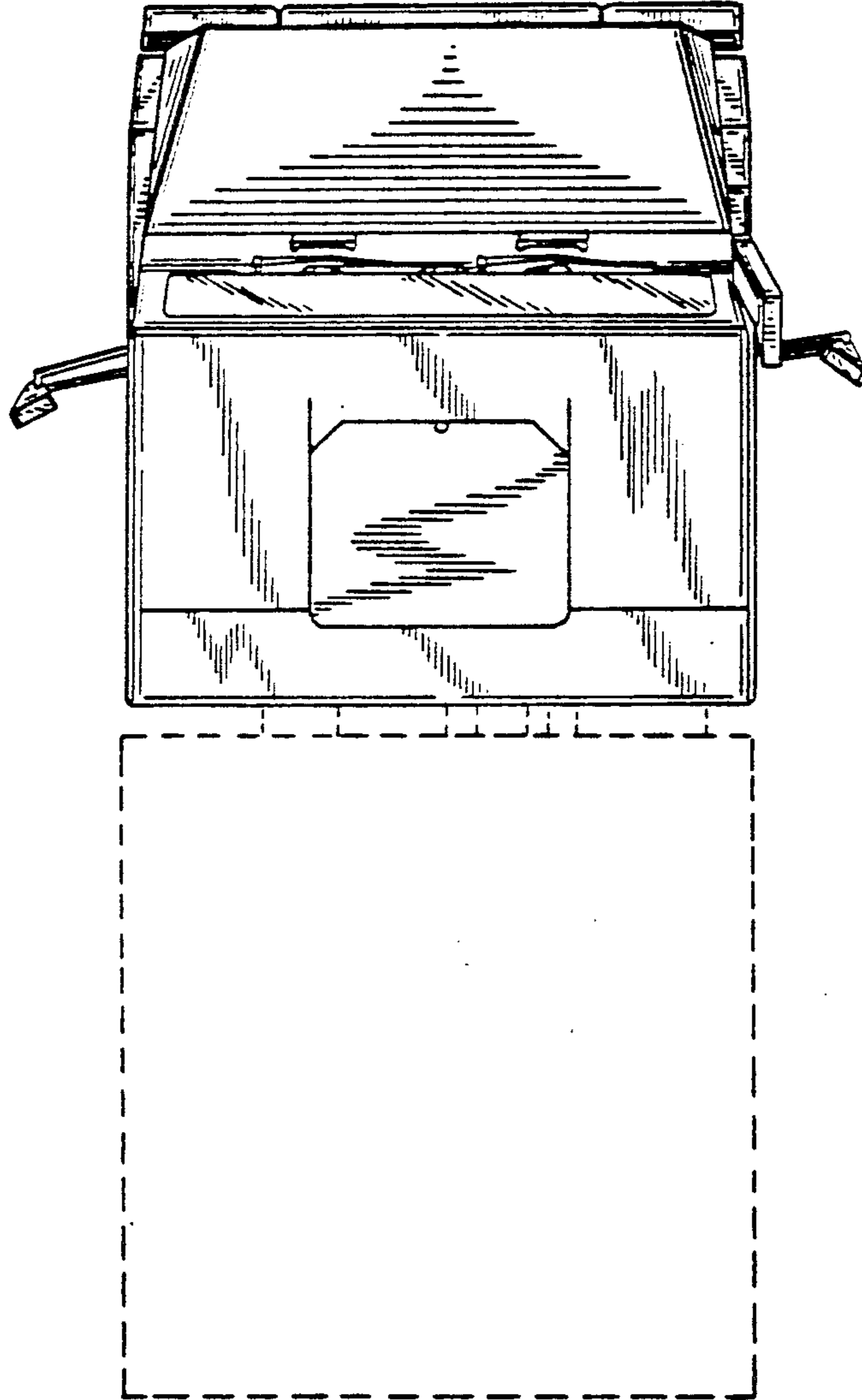

FIG. 19

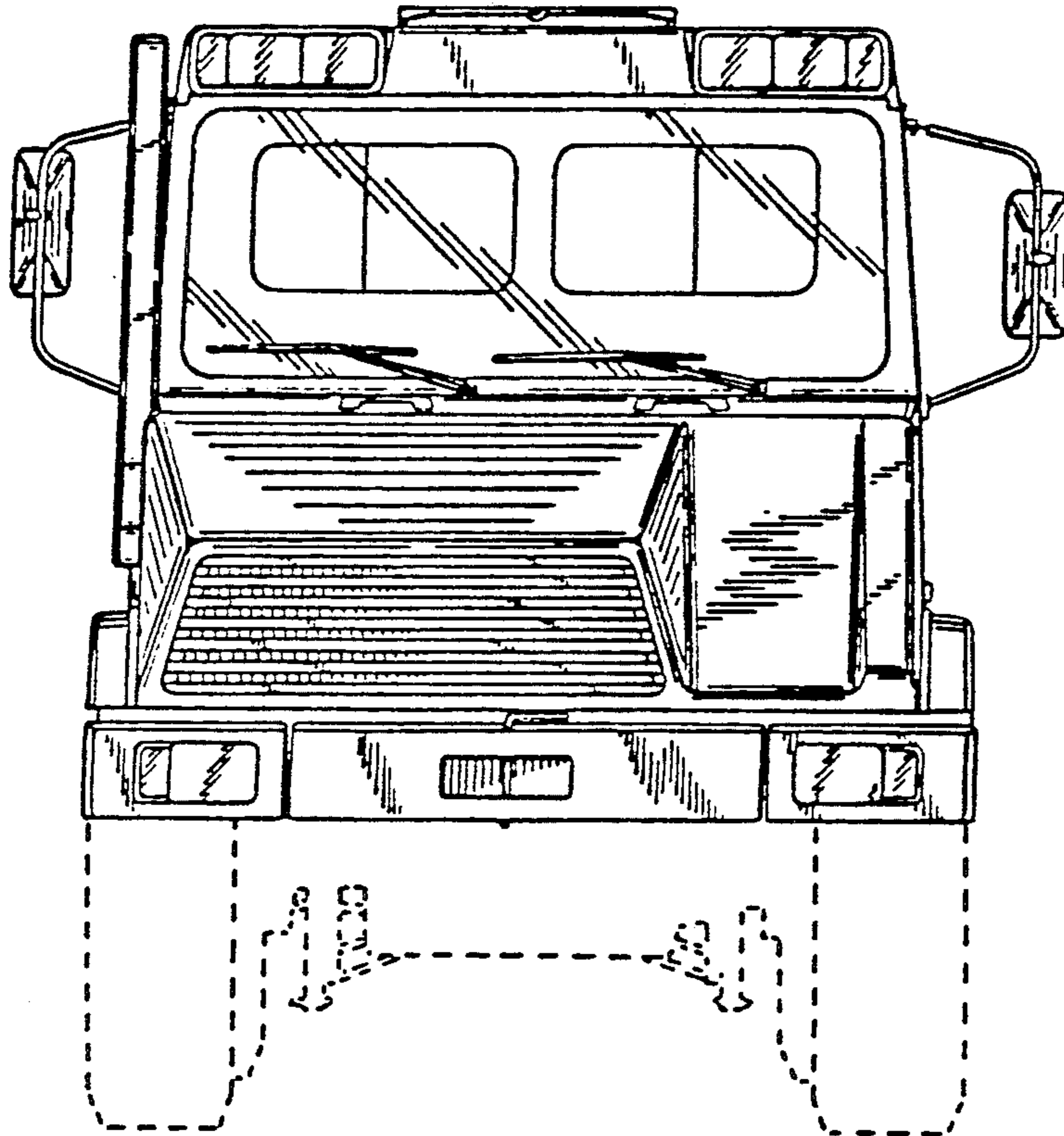

FIG. 20

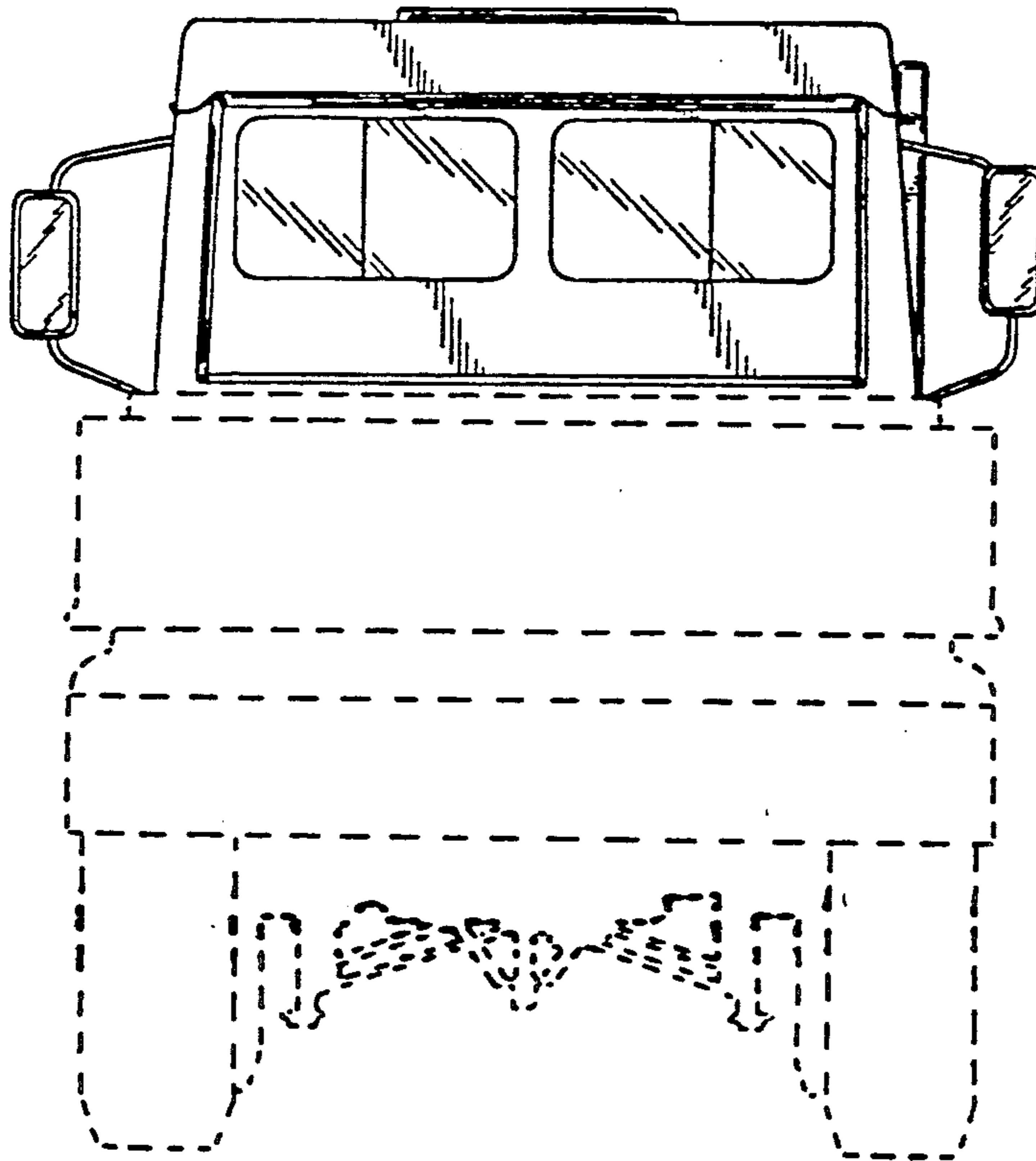

FIG. 21

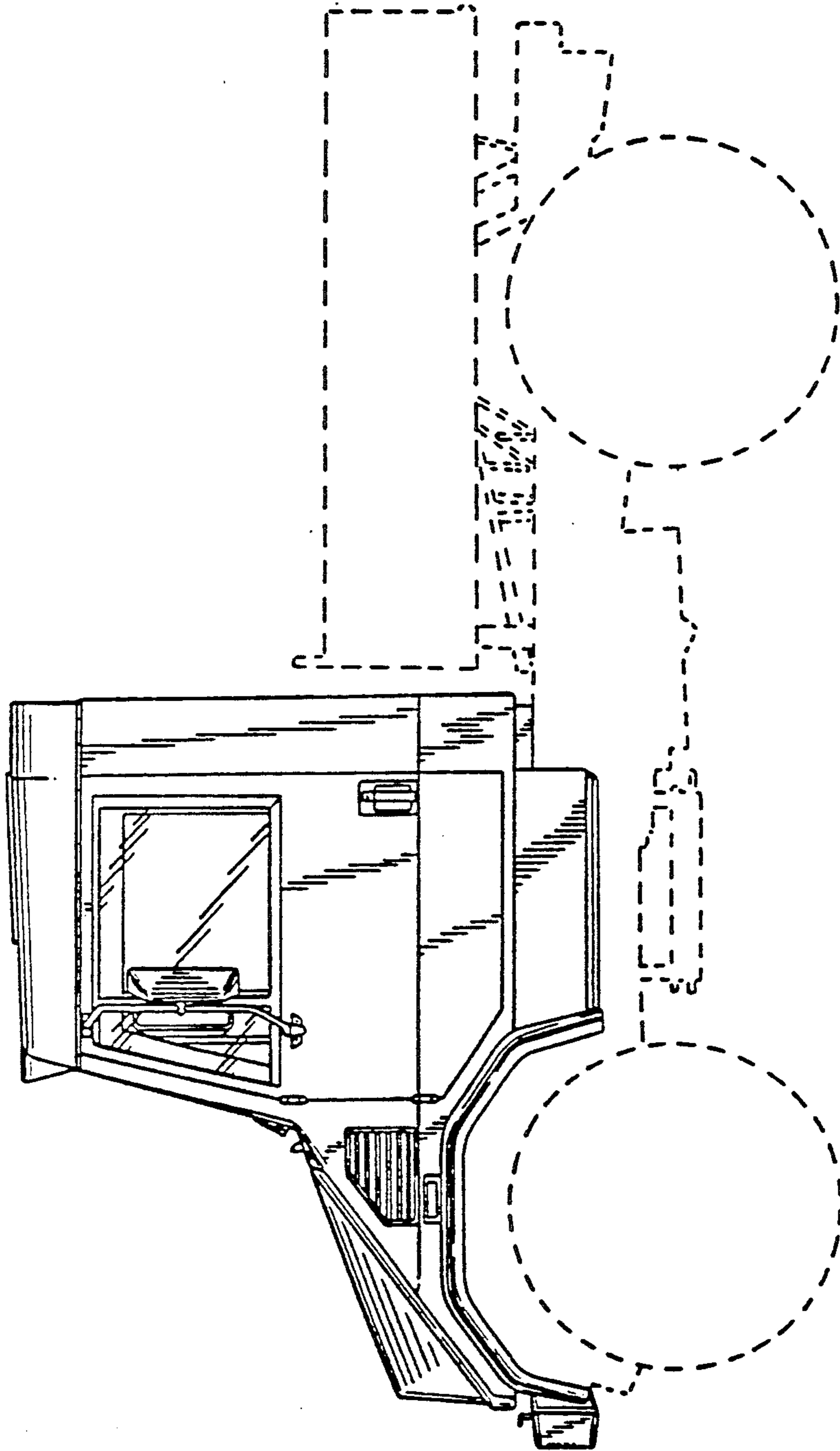

FIG. 22

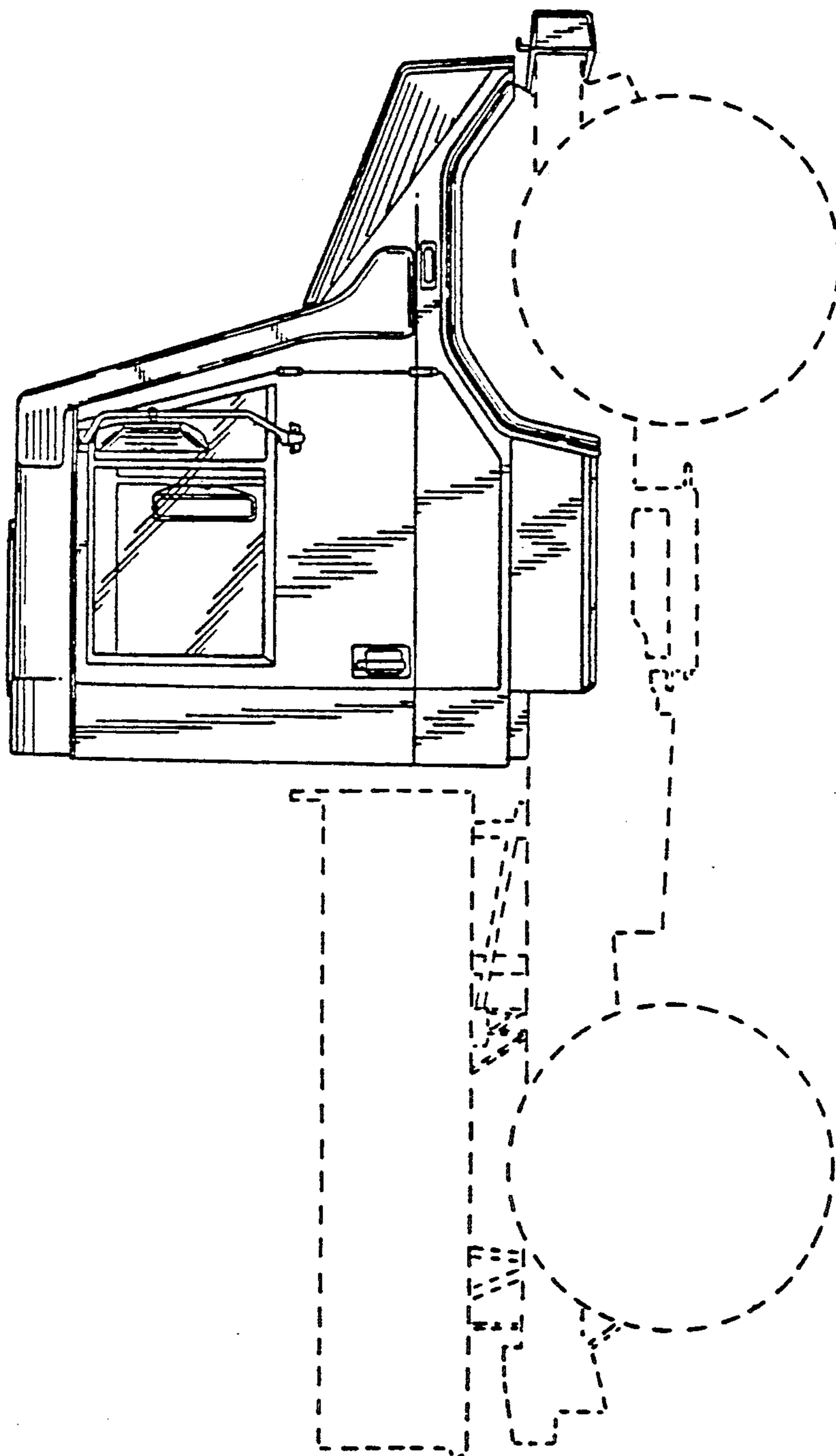

FIG. 23

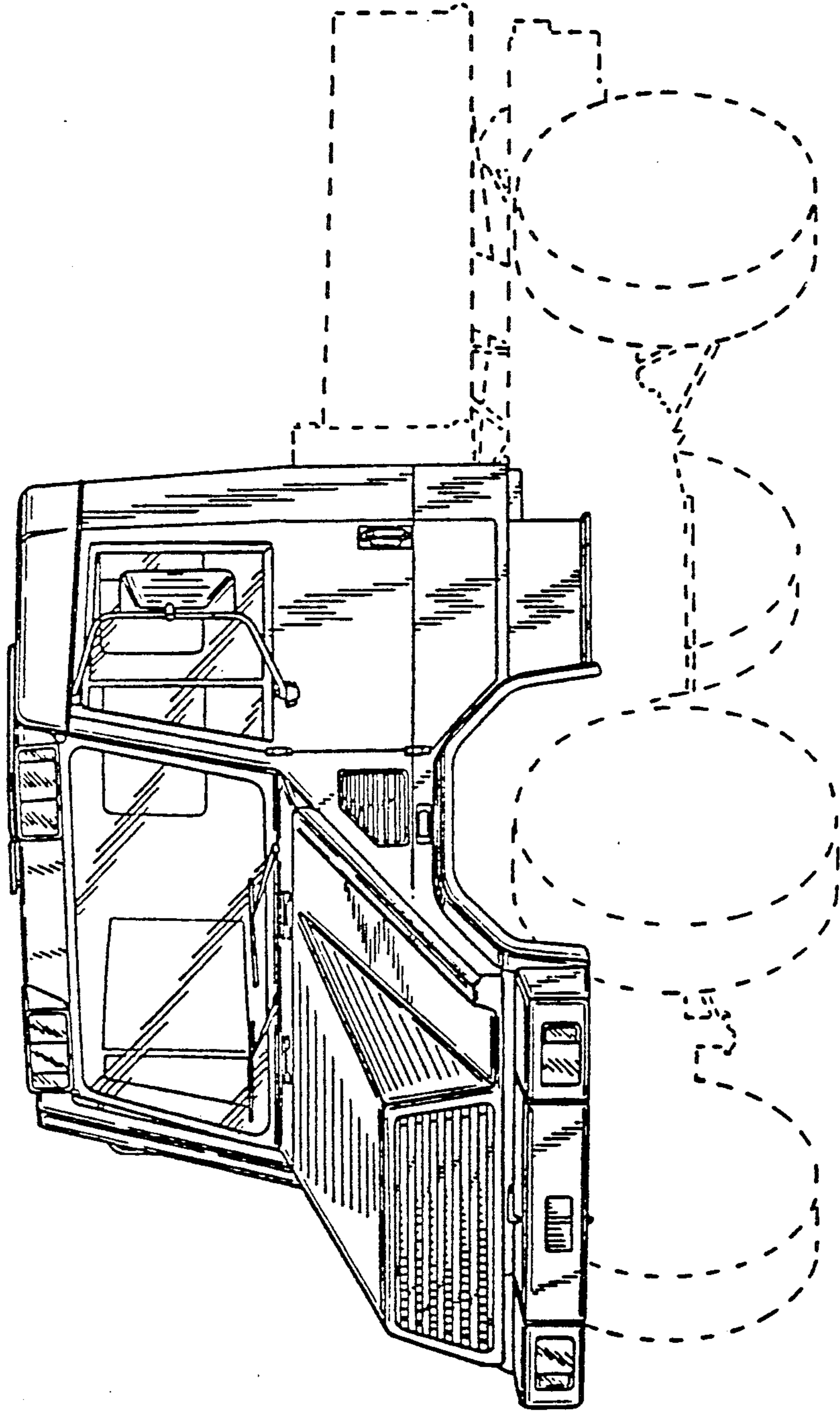

FIG. 24

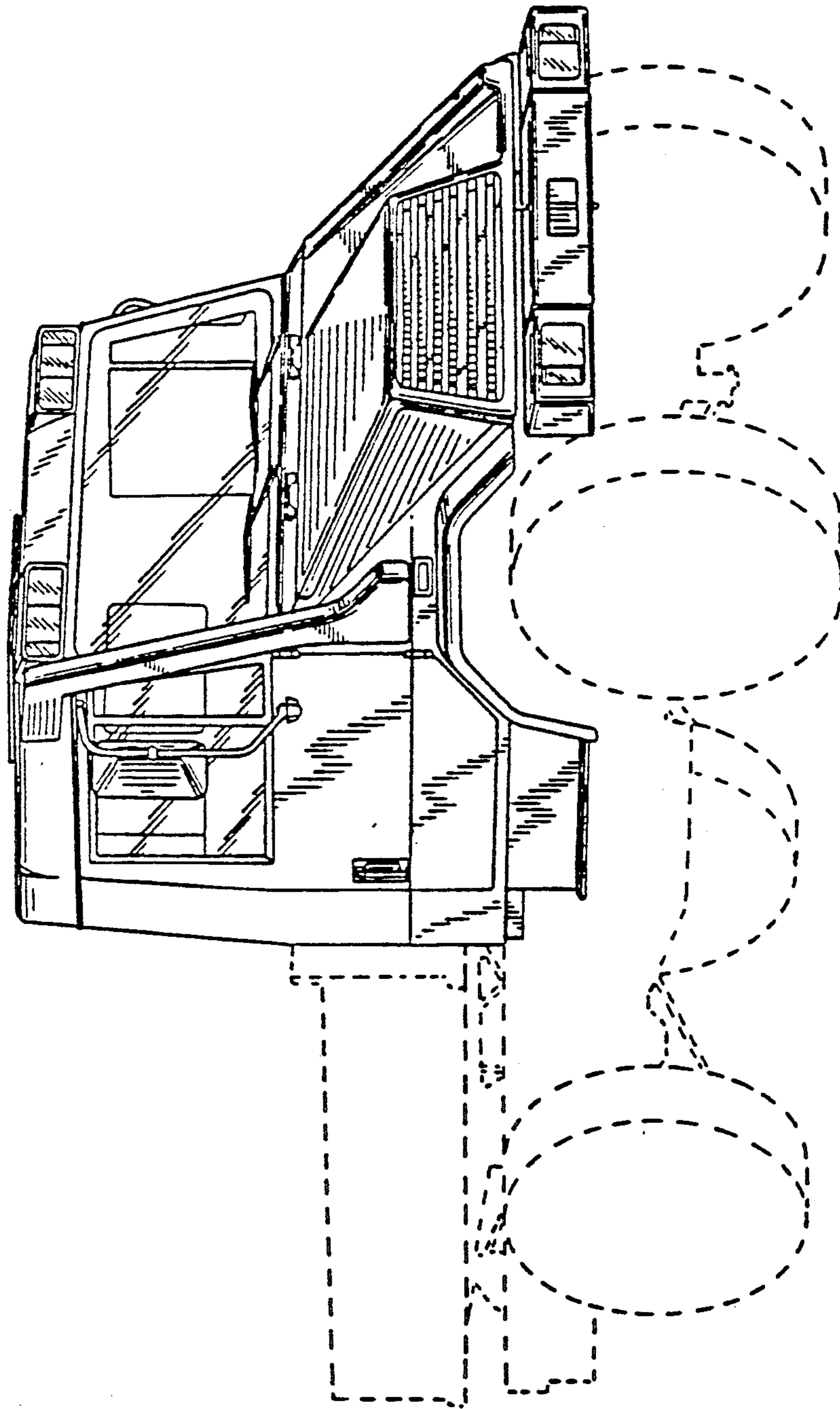

FIG. 25

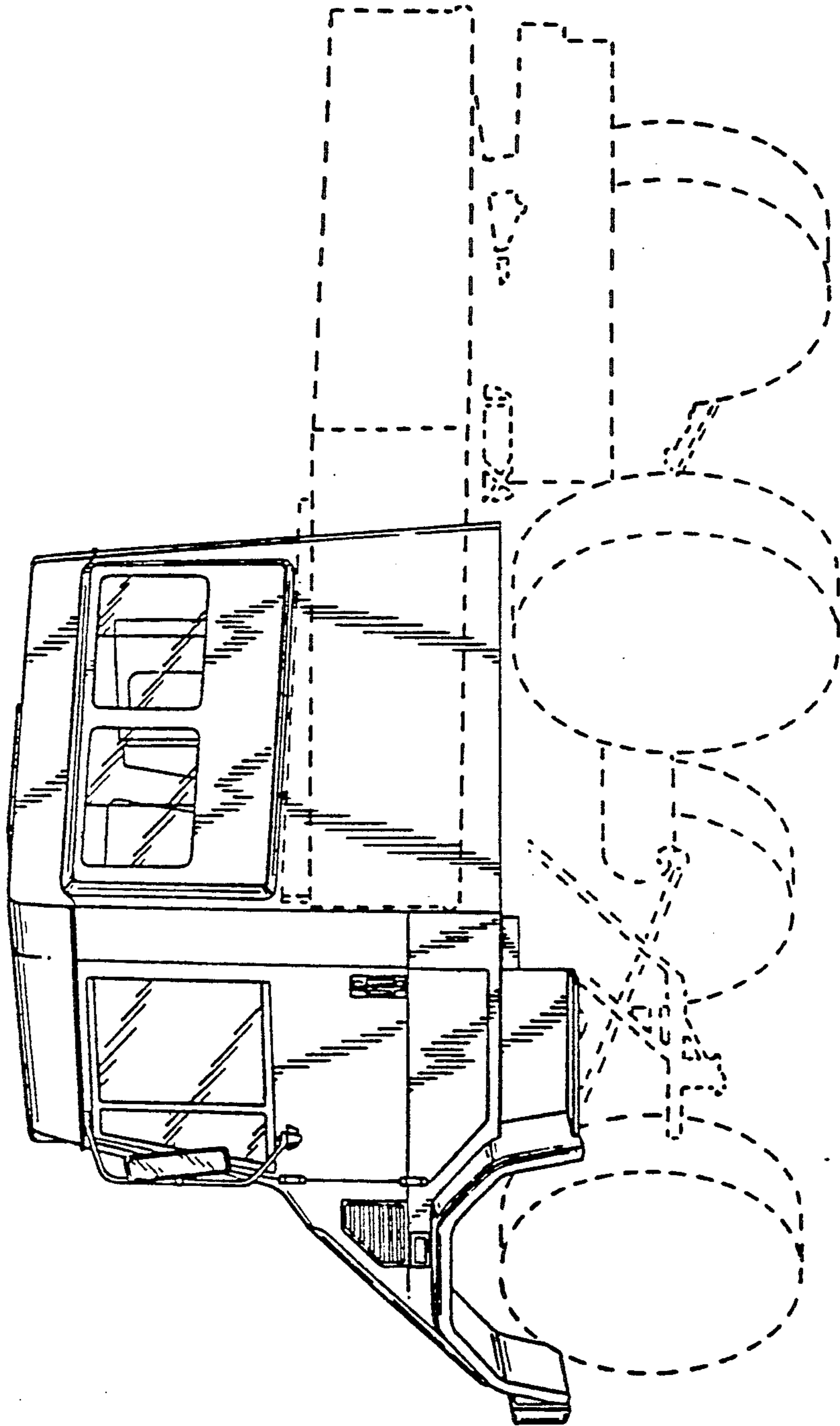

FIG. 26

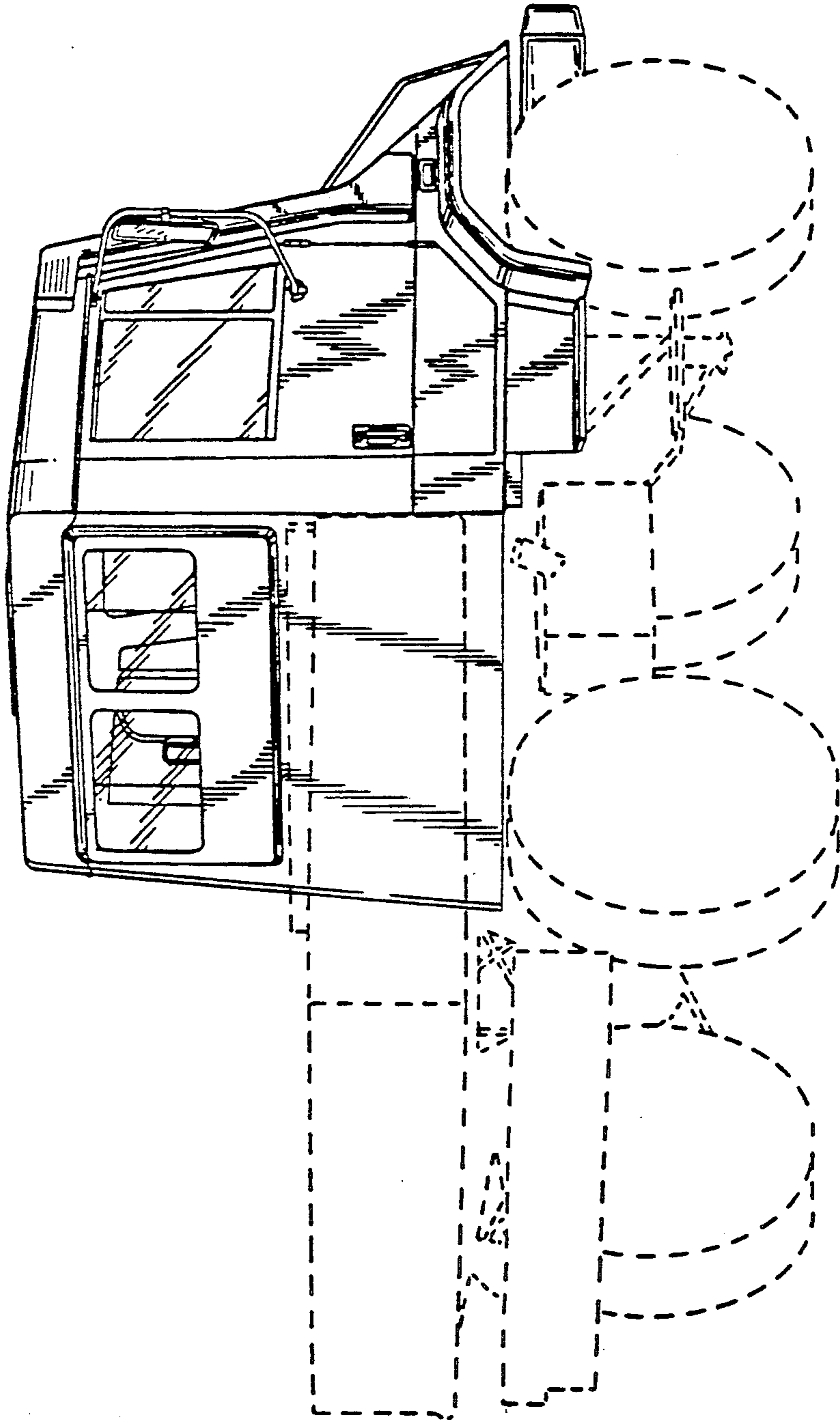

FIG. 27

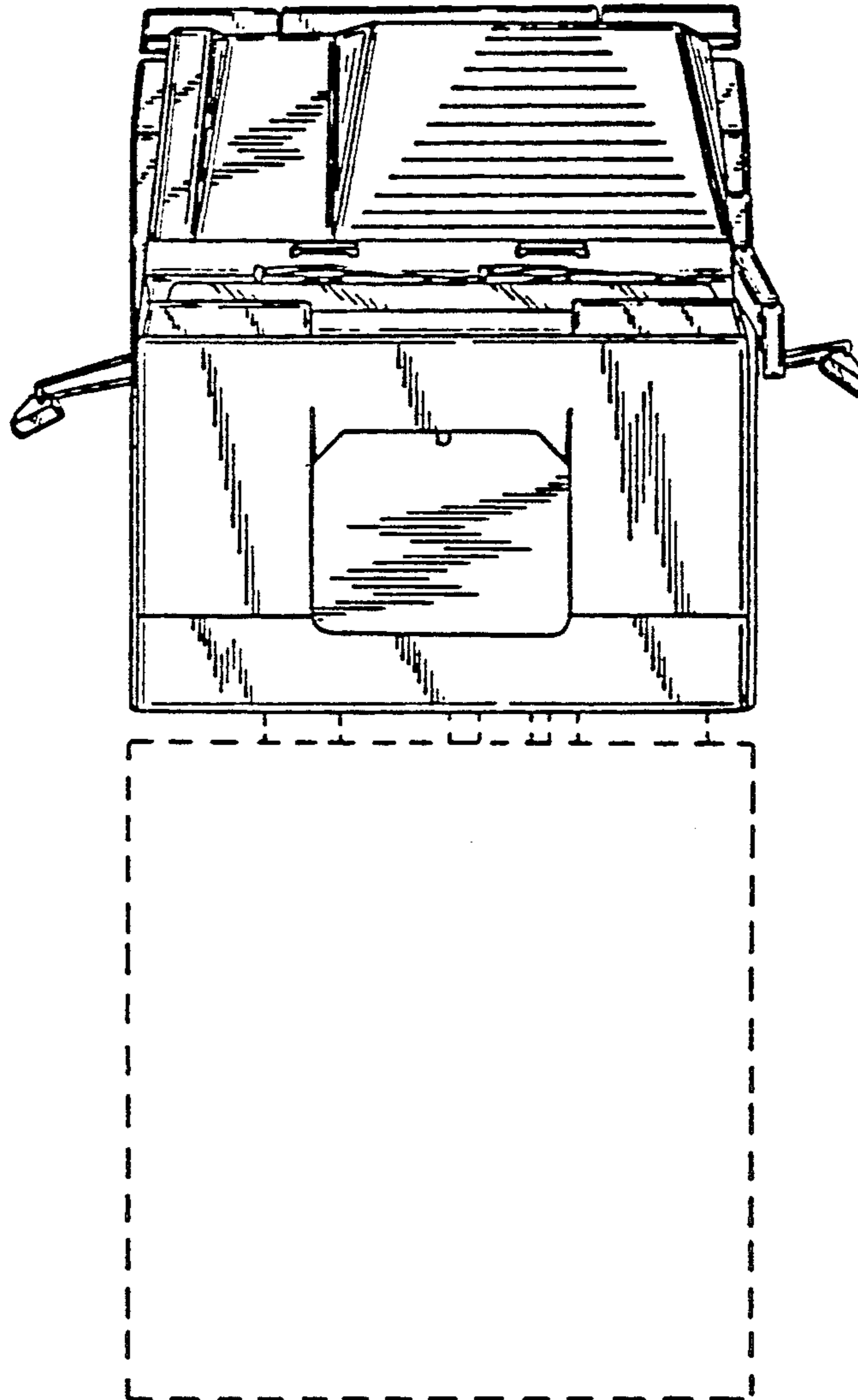

FIG. 28

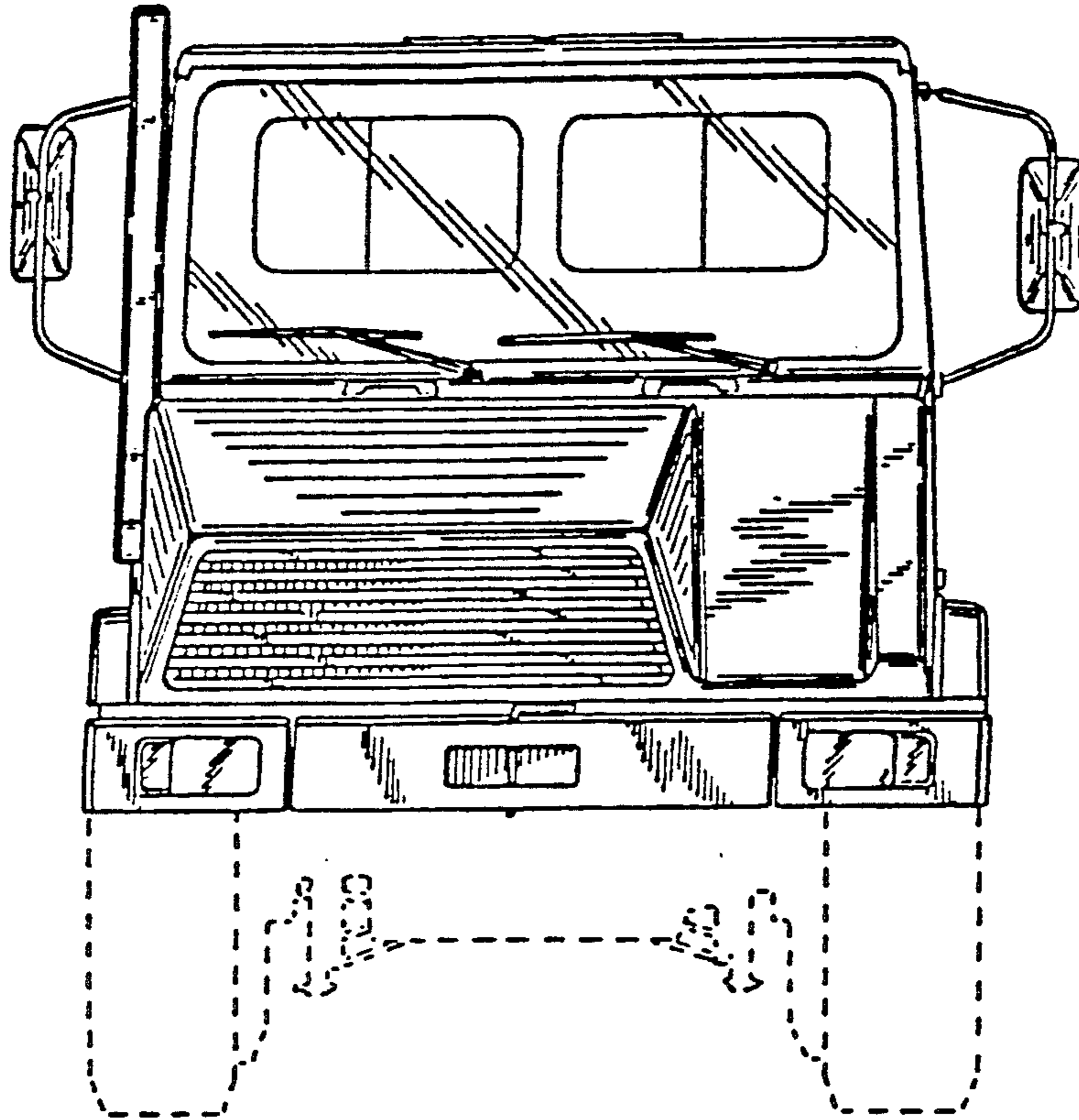

FIG. 29

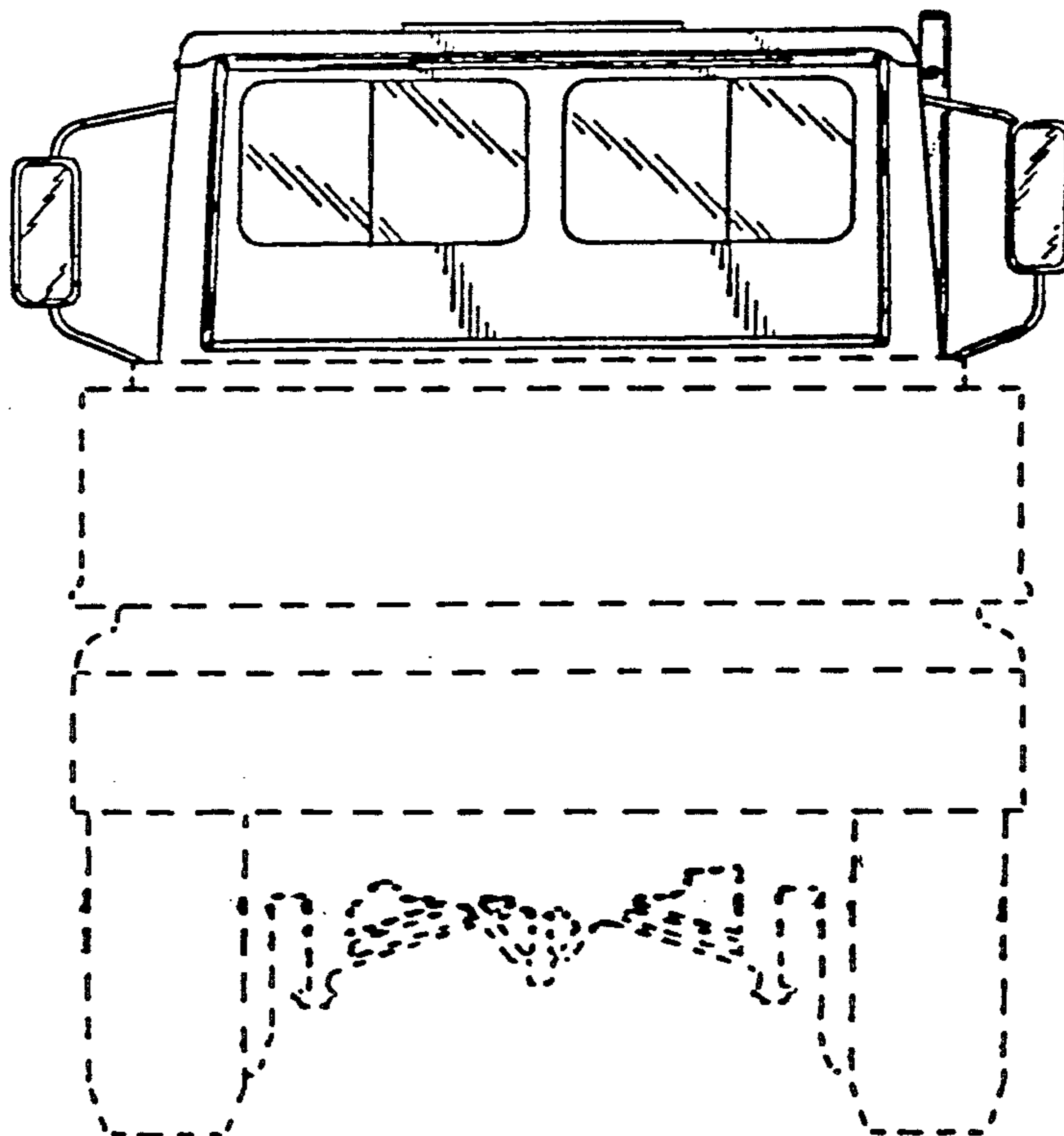

FIG. 30

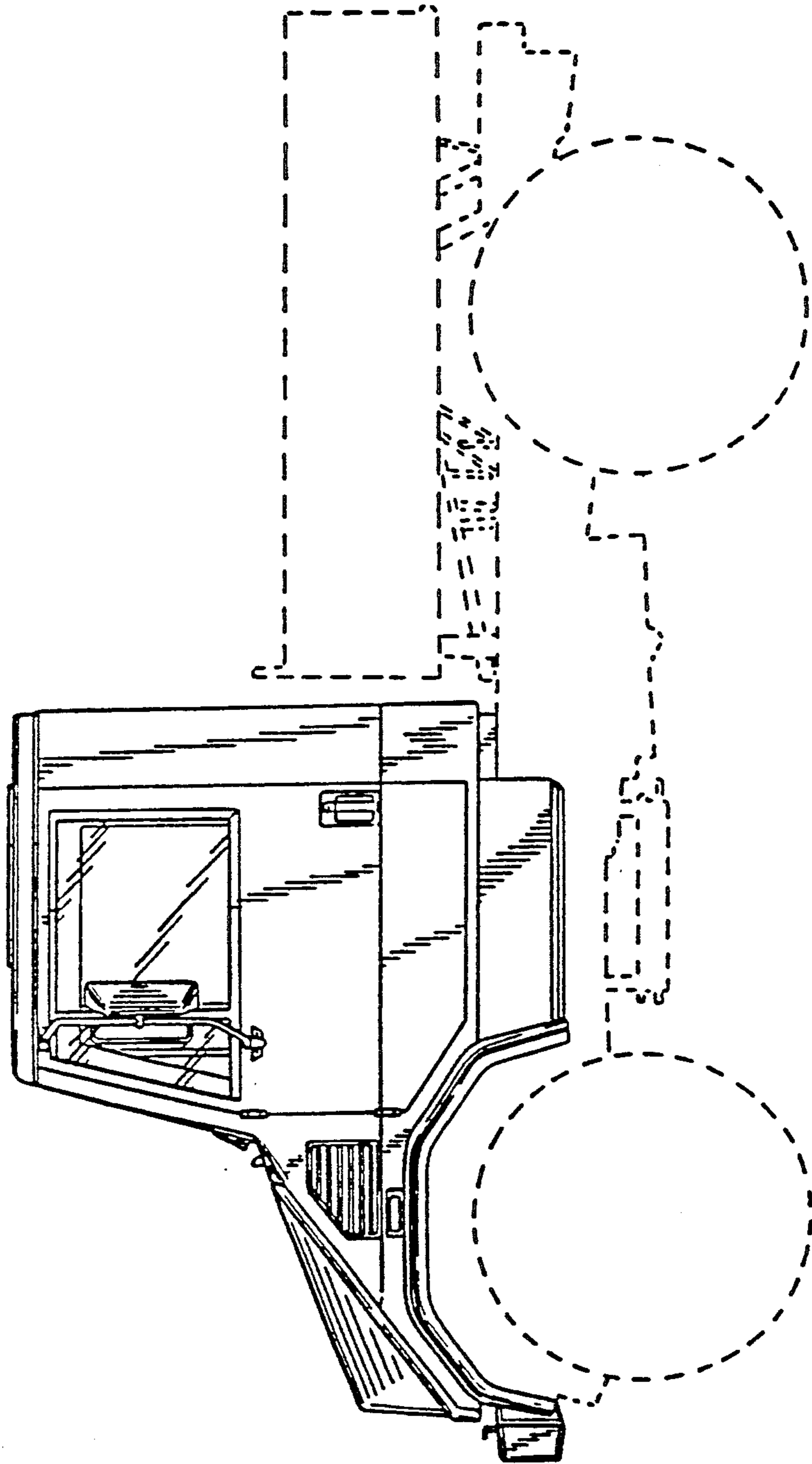

FIG. 31

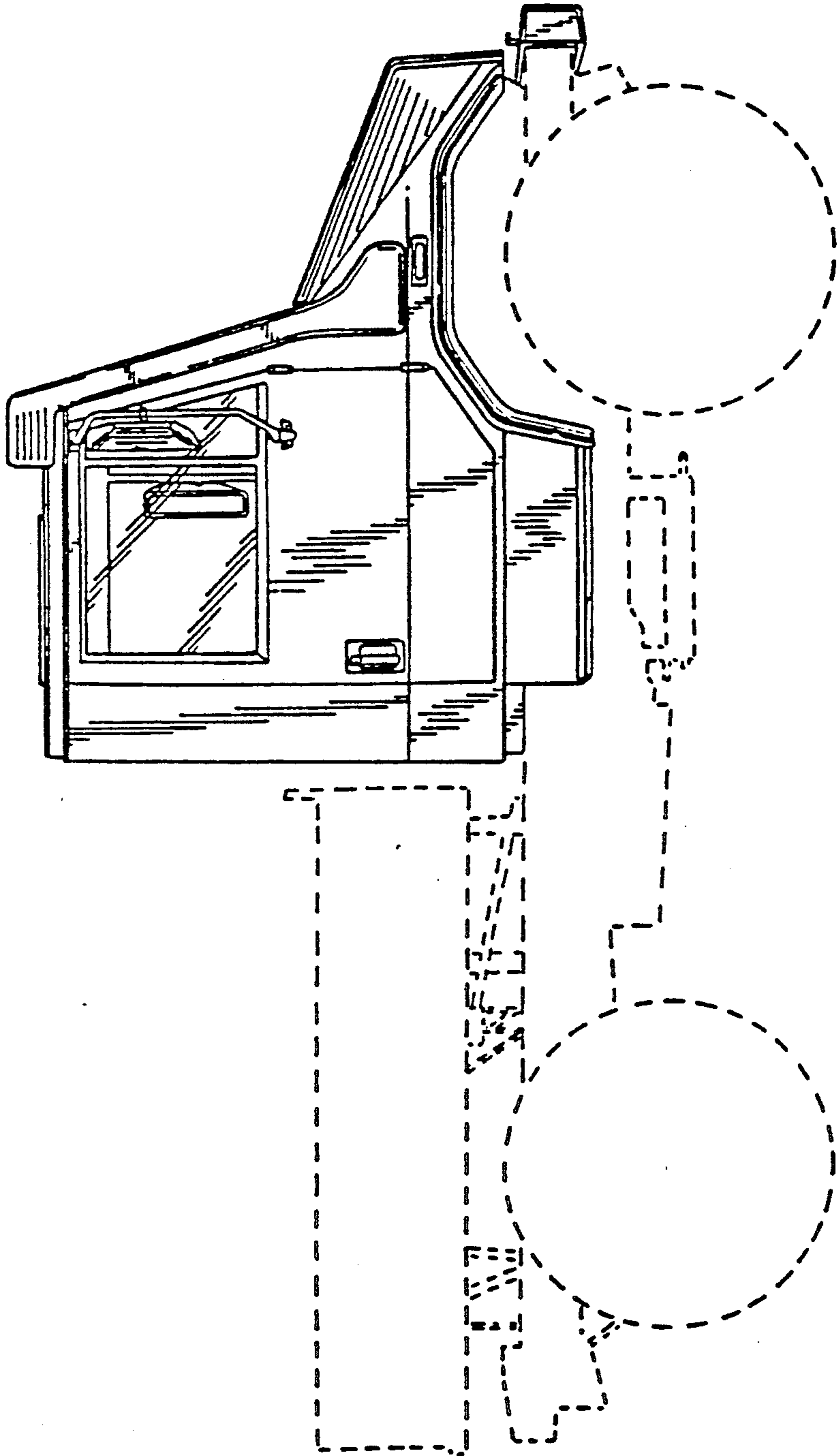

FIG. 32

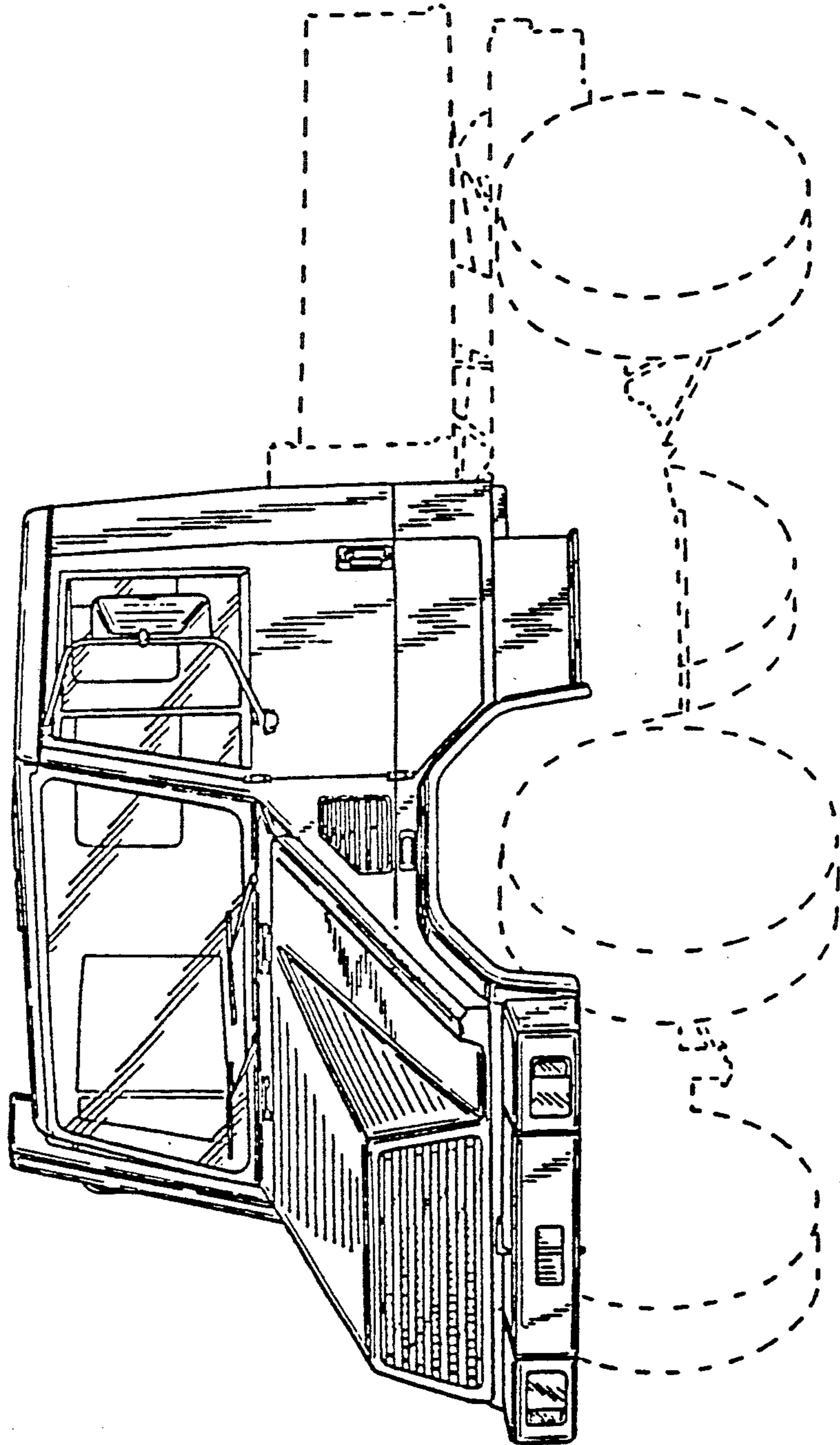

FIG. 33

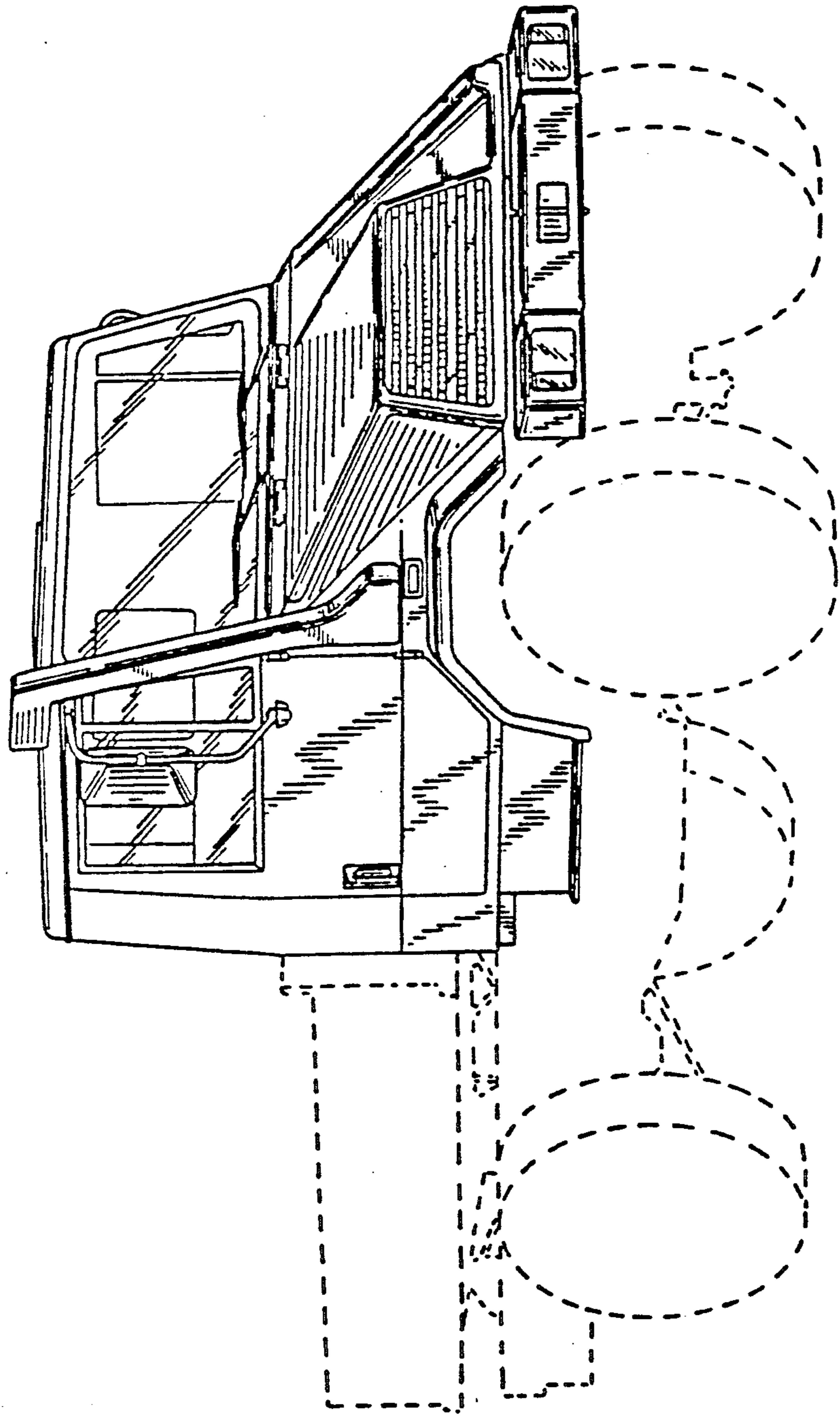

FIG. 34

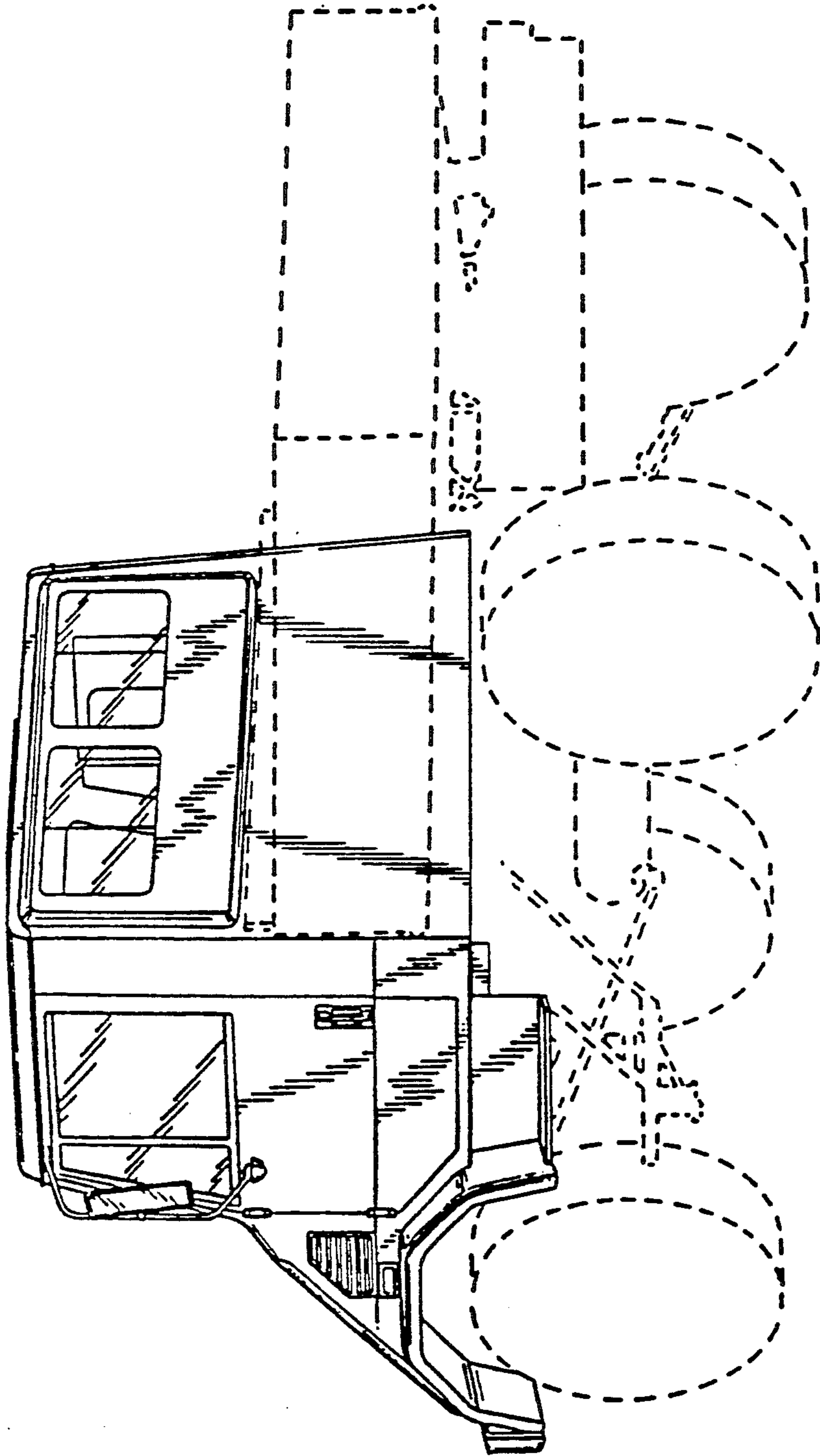
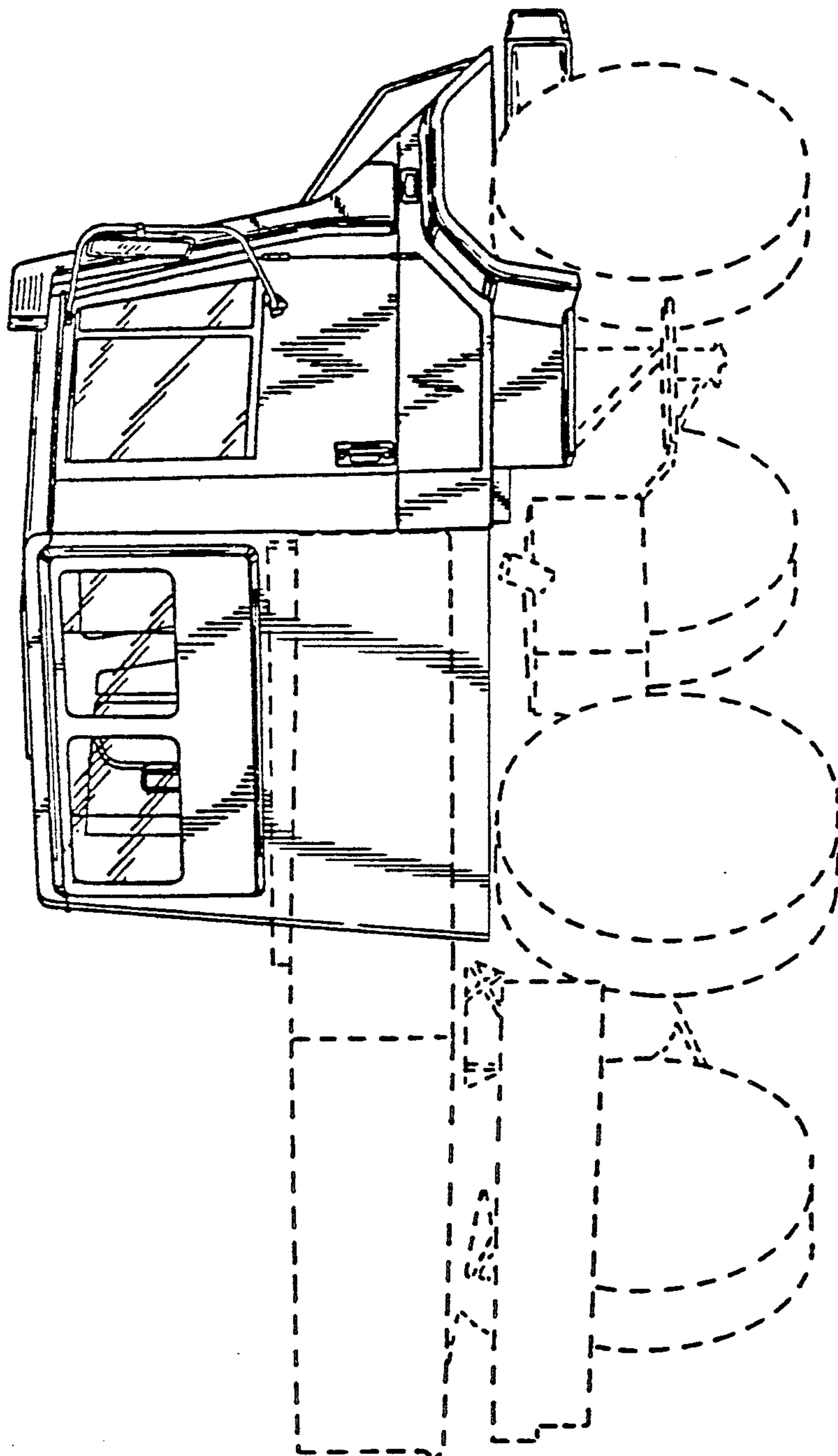

FIG. 35



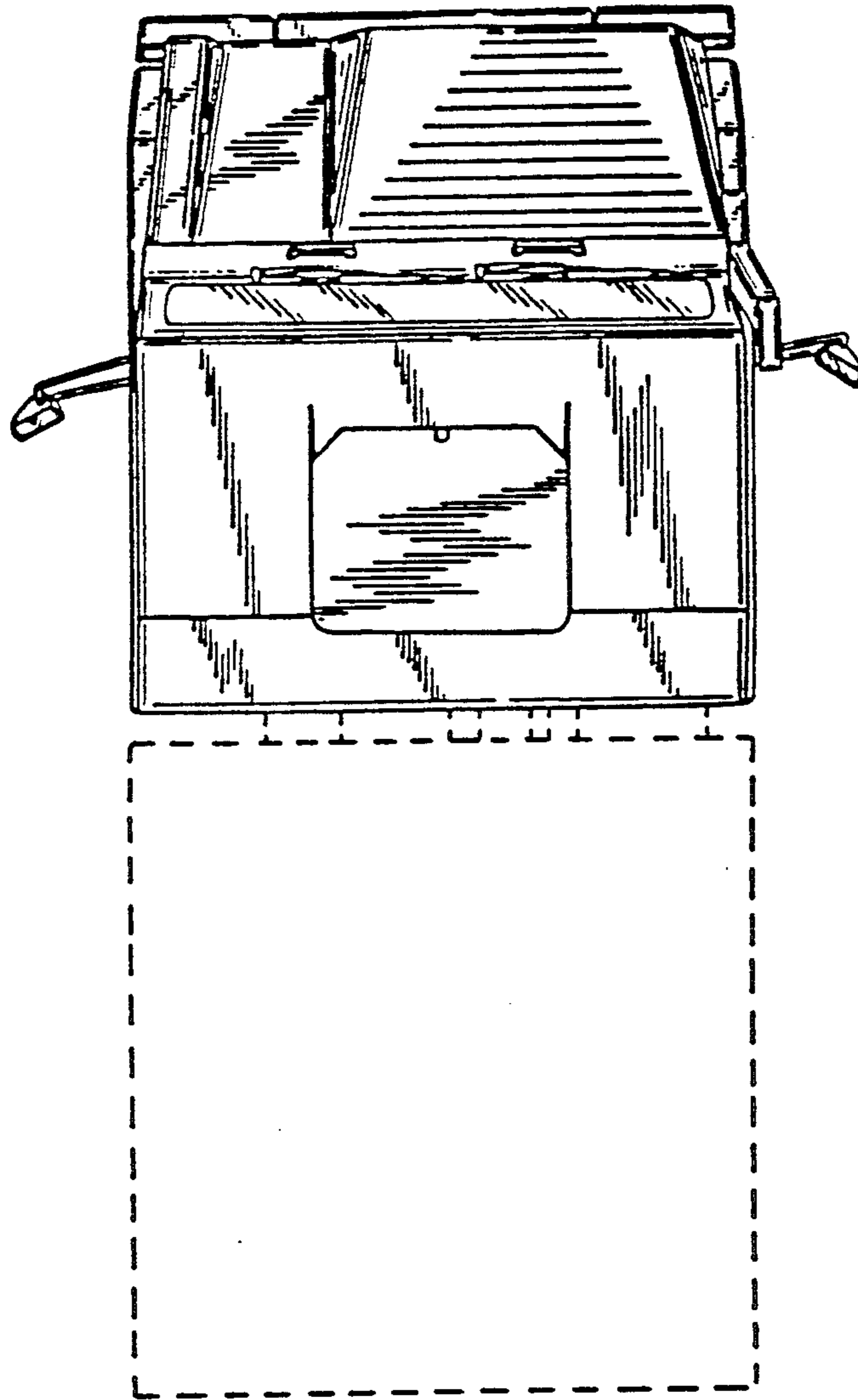

FIG. 36

FIG. 37

