



US00D327354S

United States Patent [19]

Inman

[11] Patent Number: Des. 327,354

[45] Date of Patent: ** Jun. 23, 1992

[54] **ADJUSTABLE TRAILER JACK BASE**

3,733,051 5/1973 Bollinger 254/94

[76] Inventor: Paul A. Inman, 4213 N. Dearing Rd.,
Parma, Mich. 49269

Primary Examiner—Wallace R. Burke
Assistant Examiner—H. Baynham
Attorney, Agent, or Firm—Leon Gilden

[**] Term: 14 Years

[21] Appl. No.: 539,538

[57] **CLAIM**

The ornamental design for an adjustable trailer jack base, as shown and described.

[22] Filed: Jun. 15, 1990

[52] U.S. Cl. D34/31

[58] Field of Search D34/31; 280/303, 293,
280/295, 304.3; 254/93 H, 134, 420, DIG. 1,
94; 414/559; D12/106

DESCRIPTION

FIG. 1 is a front elevational view of the adjustable trailer jack base showing my new design; FIG. 2 is a rear elevational view thereof; FIG. 3 is a left side elevational view thereof; FIG. 4 is a right side elevational view thereof; FIG. 5 is a top plan view thereof; and, FIG. 6 is a bottom plan view thereof.

[56] **References Cited**

U.S. PATENT DOCUMENTS

D. 228,300 9/1973 Kearns D34/31
3,220,699 12/1963 Falk 254/94

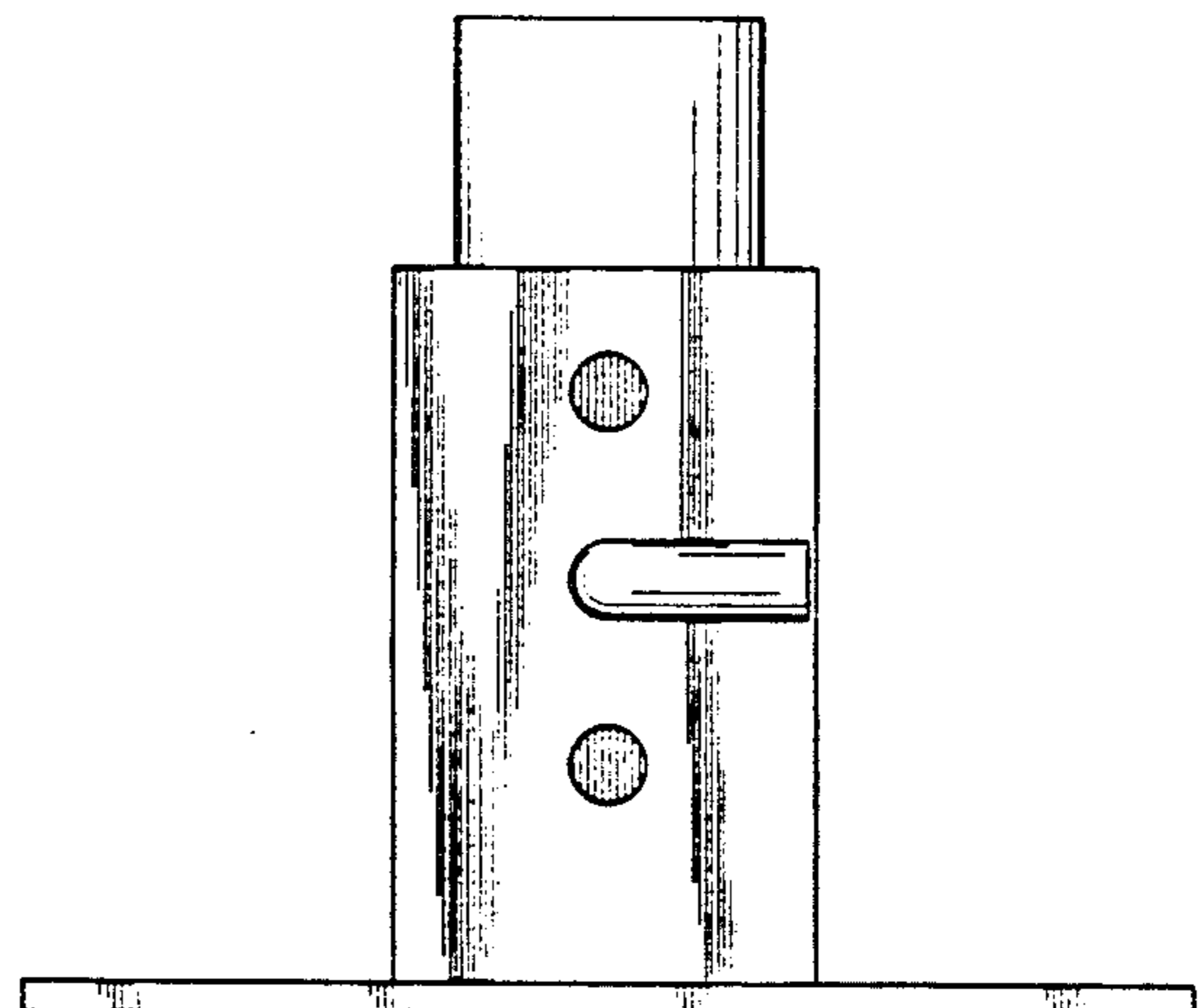
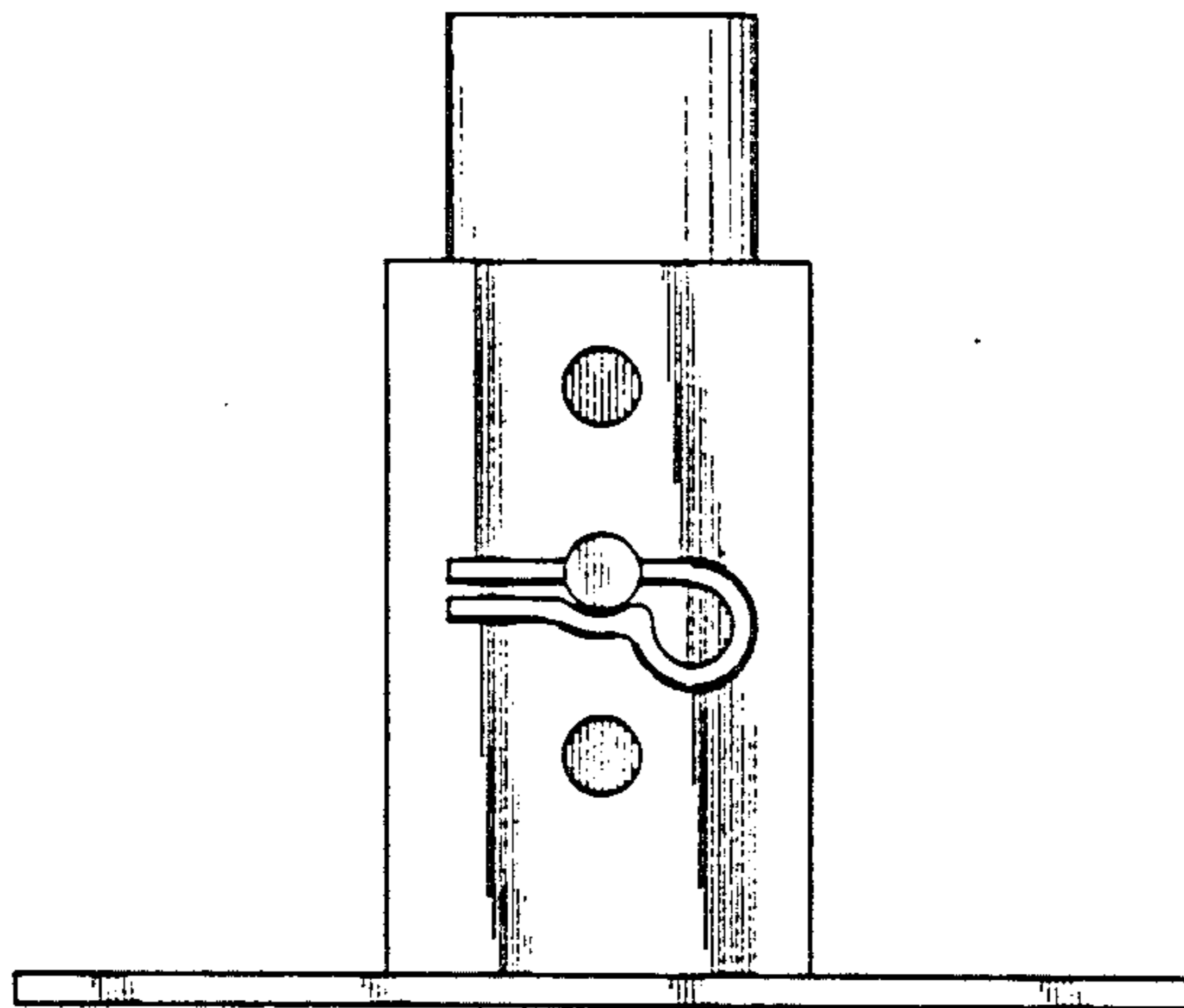
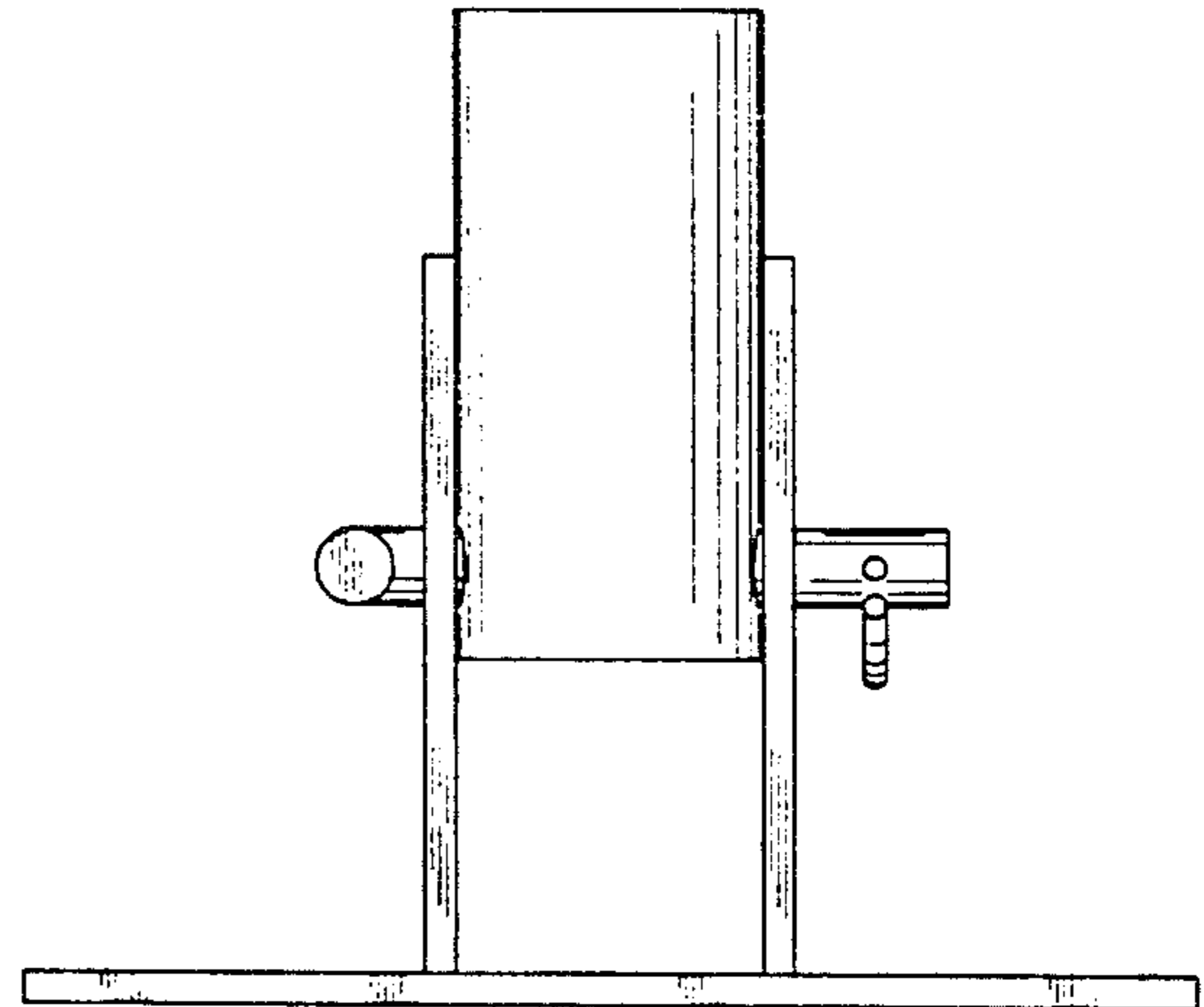
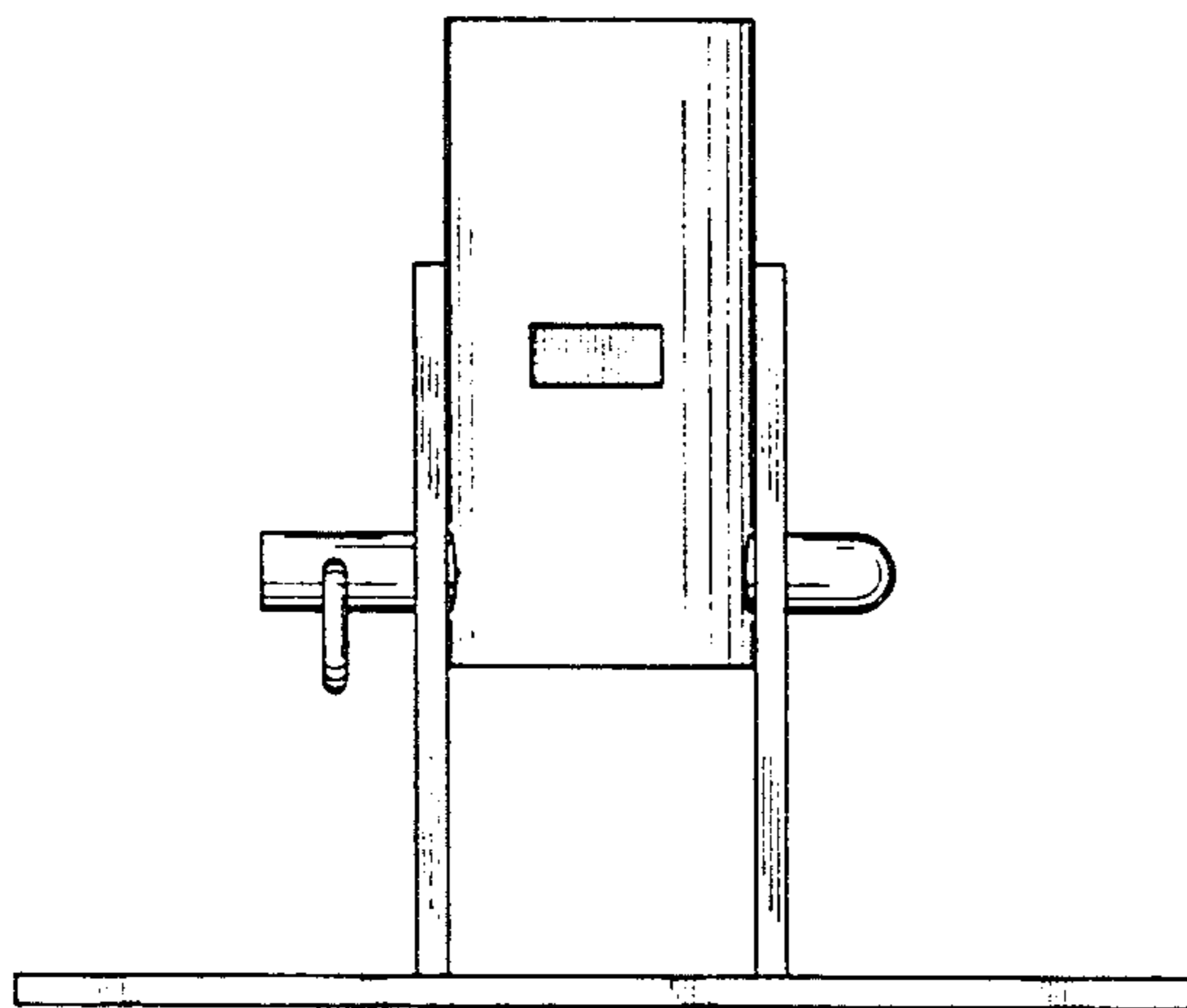

FIG. 1

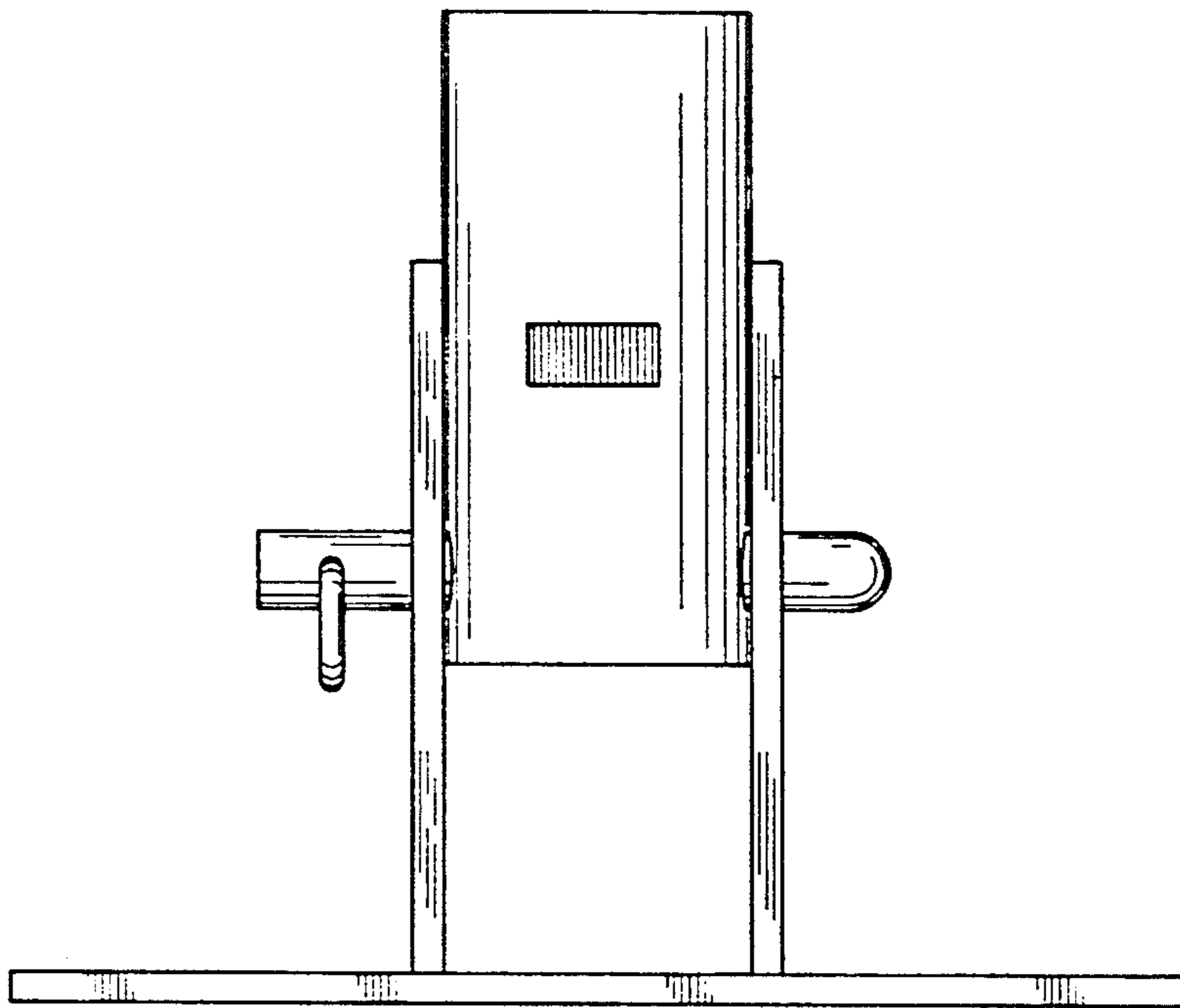

FIG. 2

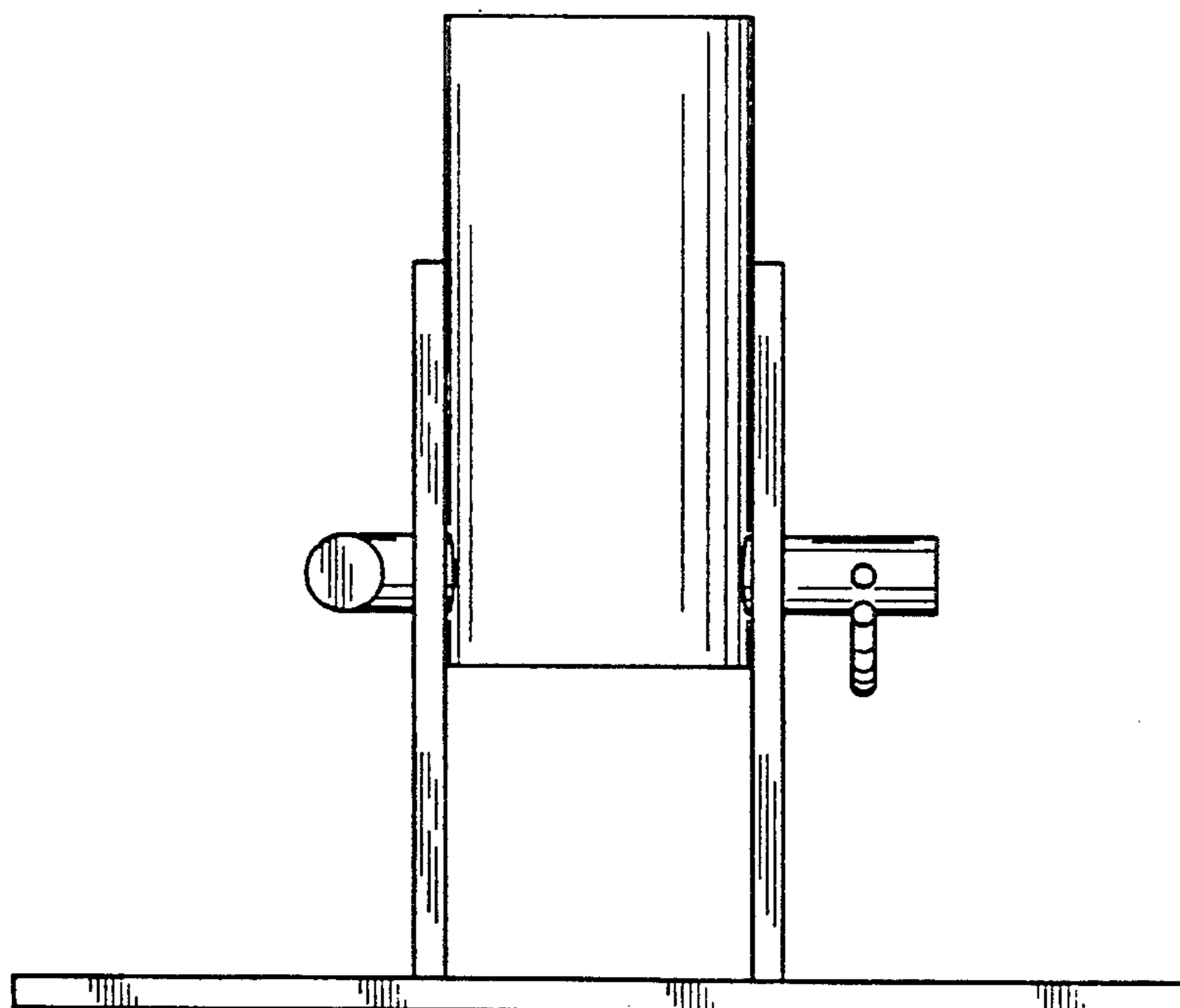

FIG. 3

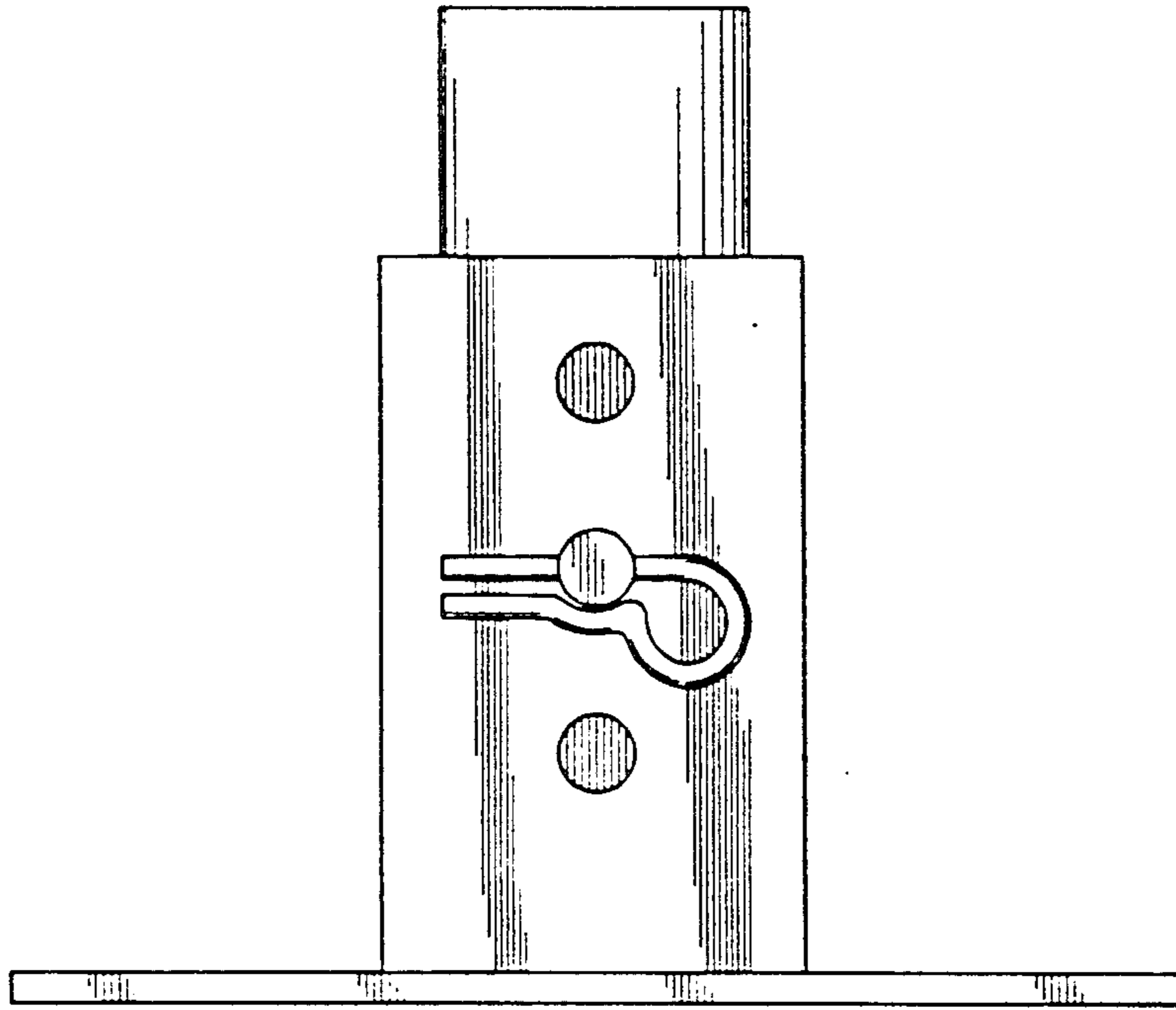

FIG. 4

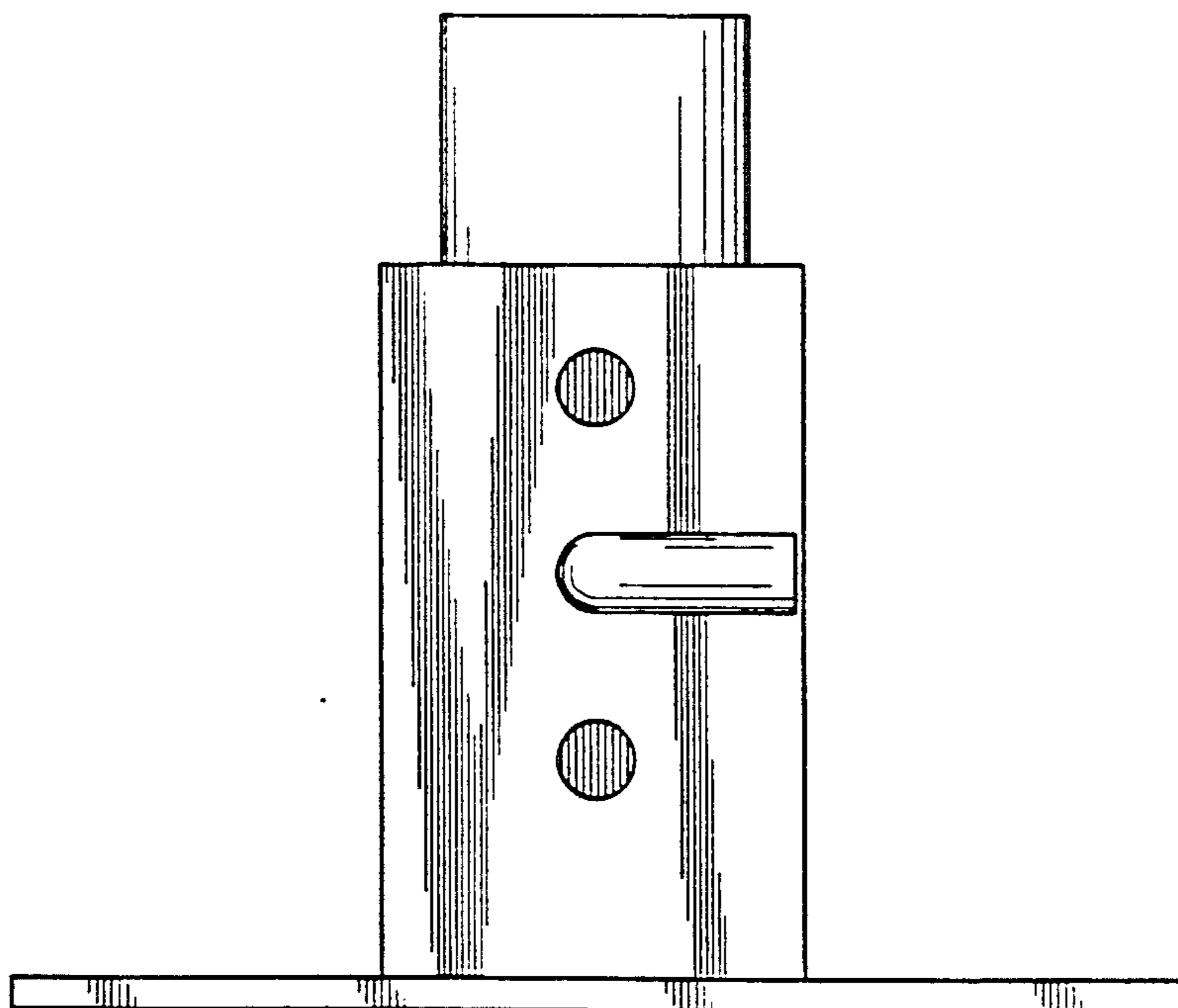

FIG. 5

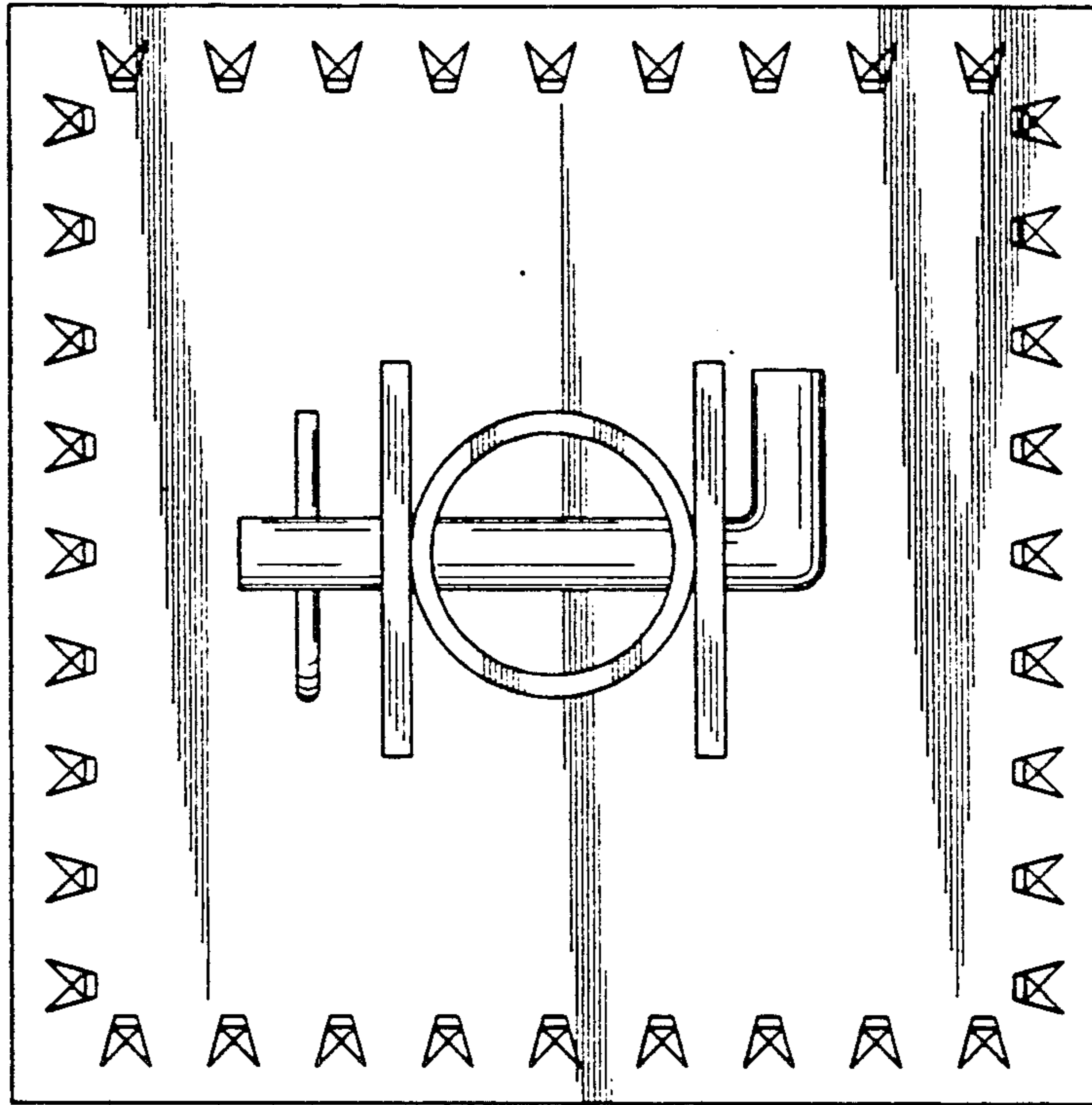

FIG. 6

