



US00D327281S

# United States Patent [19]

[11] Patent Number: **Des. 327,281**

Macomber

[45] Date of Patent: **\*\* Jun. 23, 1992**

[54] TRANSMISSION ADAPTOR FOR SHORT CAB AND CAB OVER TYPE TRUCKS

4,221,138	9/1980	Stewart et al.	74/607
4,333,358	6/1982	Grattapaglia	74/606 R X
4,442,733	4/1984	Hartz	74/606 R
4,499,391	2/1985	Sakamoto	74/606 R X
4,677,876	7/1987	Dissett	74/607 X

[76] Inventor: Clayton Macomber, 9726 - 52nd St. SE., Snohomish, Wash. 98290

[\*\*] Term: 14 Years

Primary Examiner—Donald P. Walsh  
Assistant Examiner—Jeffrey Asch  
Attorney, Agent, or Firm—Tom Secret

[21] Appl. No.: 265,480

[22] Filed: Nov. 1, 1988

[57] CLAIM

[52] U.S. Cl. .... D15/149; D15/148

The ornamental design for a transmission for short cab and cab over type trucks, as shown and described.

[58] Field of Search ..... 74/606 R, 607; 33/722, 33/730; 116/227; 141/94, 95; 184/6.4, 6.12, 108, 1.5, 105.1; D15/148, 150, 149, 151, 199, 152; D12/160

DESCRIPTION

[56] References Cited

U.S. PATENT DOCUMENTS

D. 214,758	7/1969	Fawick	D15/148
D. 279,570	7/1985	Gentile	D15/149
2,124,406	7/1938	Spatta	607/74 X
2,688,102	8/1954	Jackson	184/105.1 X
3,220,104	11/1965	Puidokas et al.	74/607 X

FIG. 1 is a front elevational view of a transmission adaptor for short cab and cab over type trucks showing my new design;

FIG. 2 is an enlarged right side elevational view, the left side being a mirror image thereof;

FIG. 3 is an enlarged top plan view, the bottom being a mirror image thereof;

FIG. 4 is a rear elevational view; and,

FIG. 5 is a rear perspective view thereof.

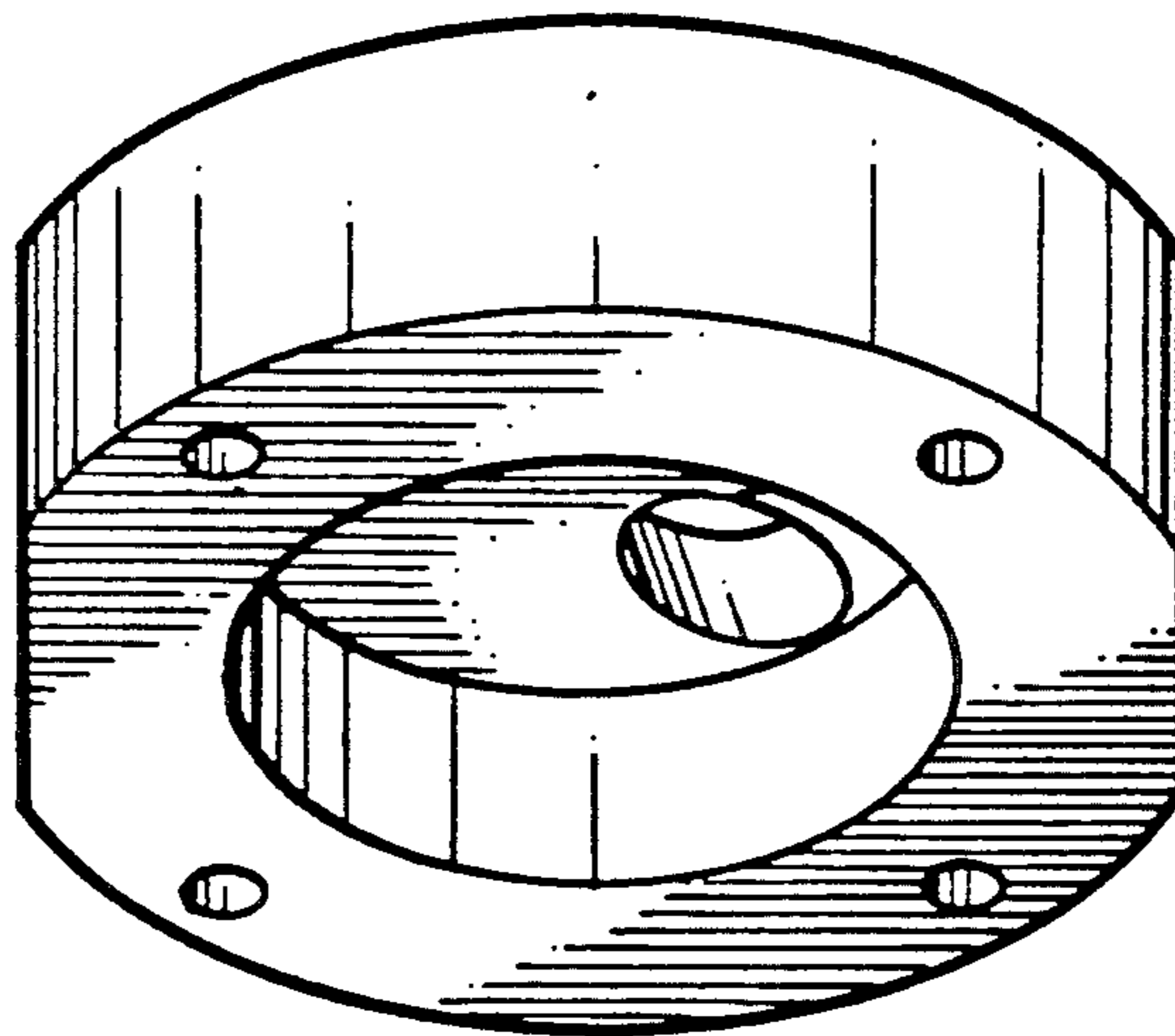

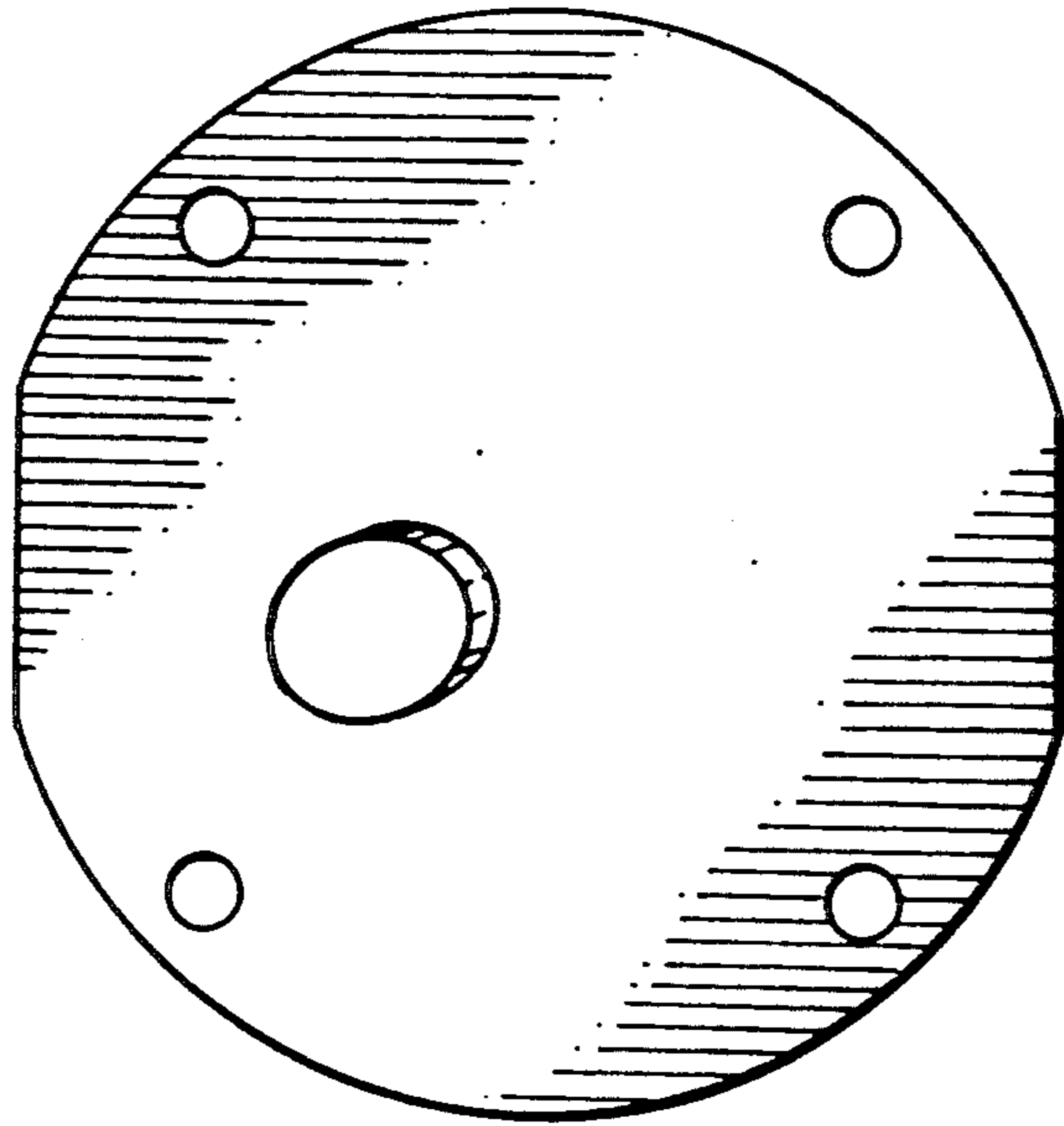

FIG. 1

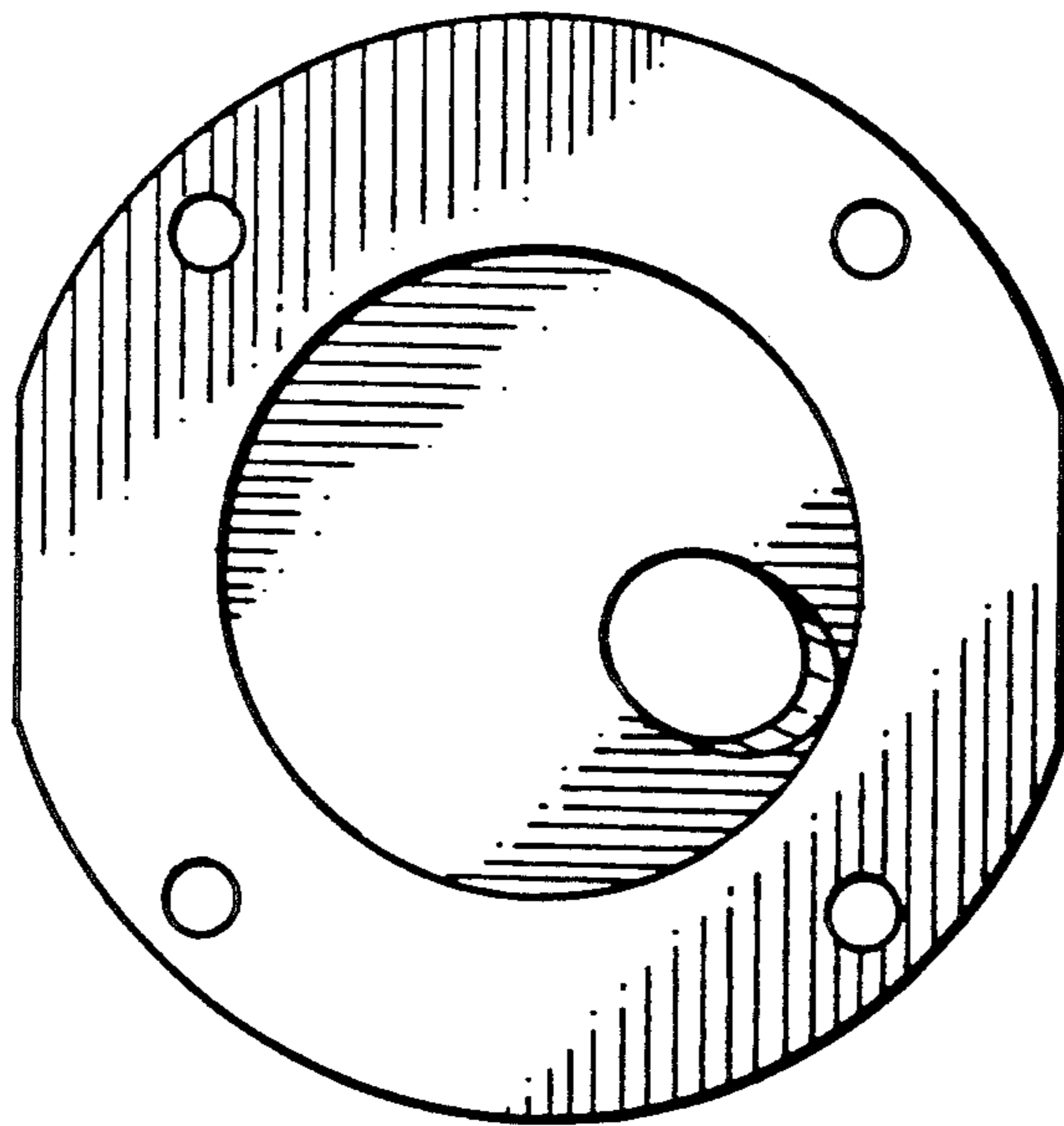

FIG. 4

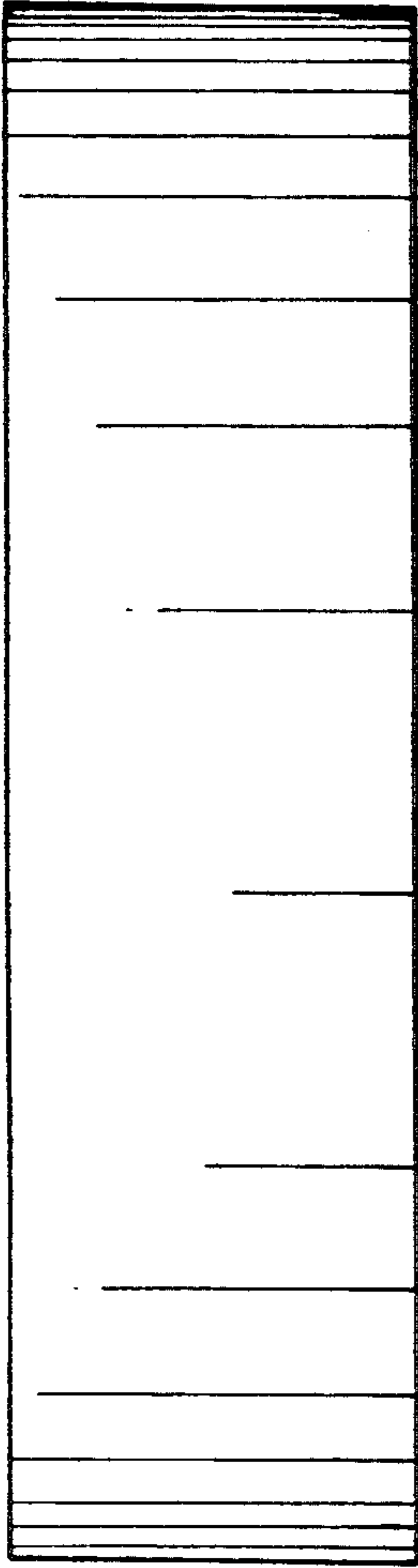

FIG. 3

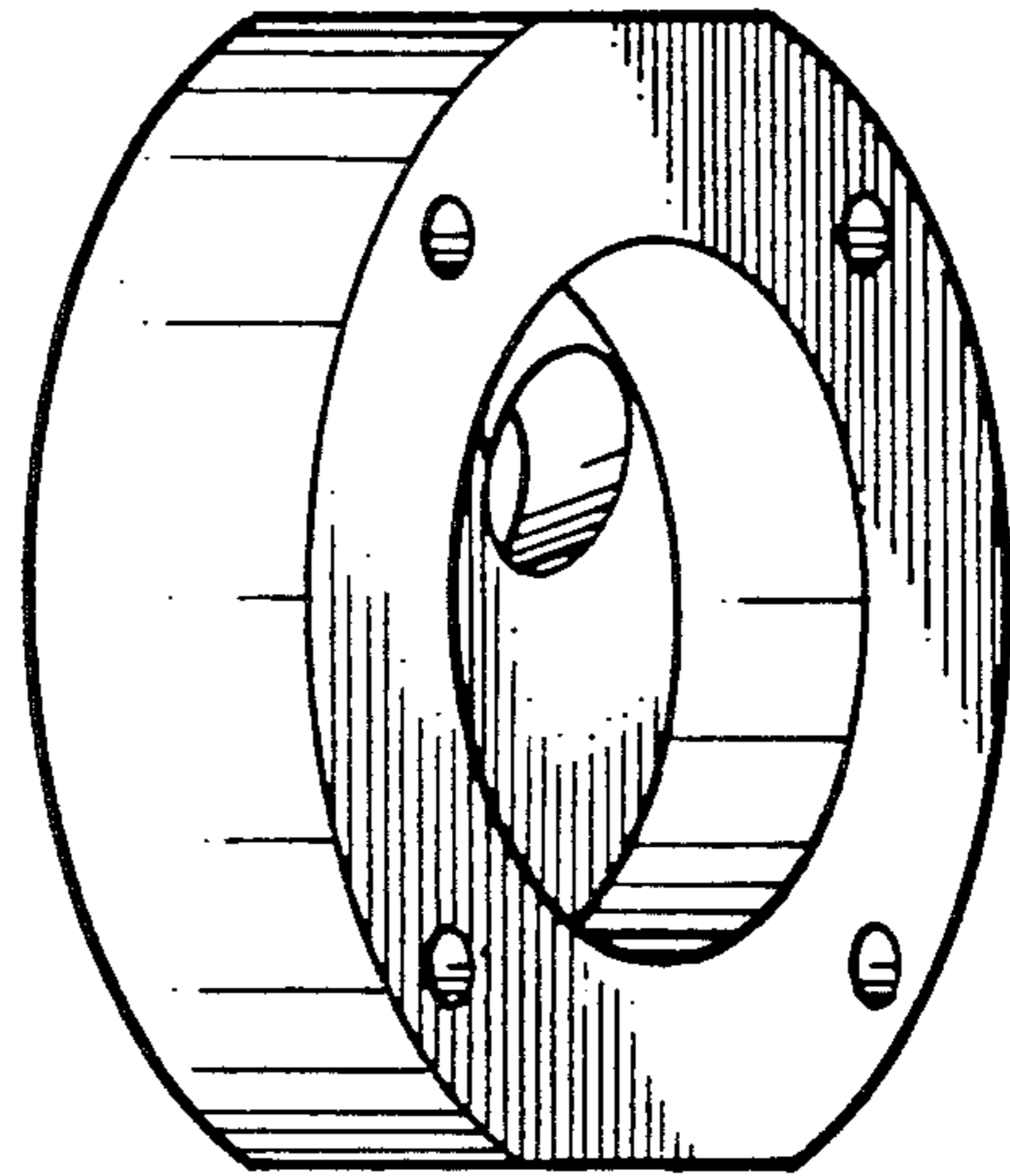

FIG. 5

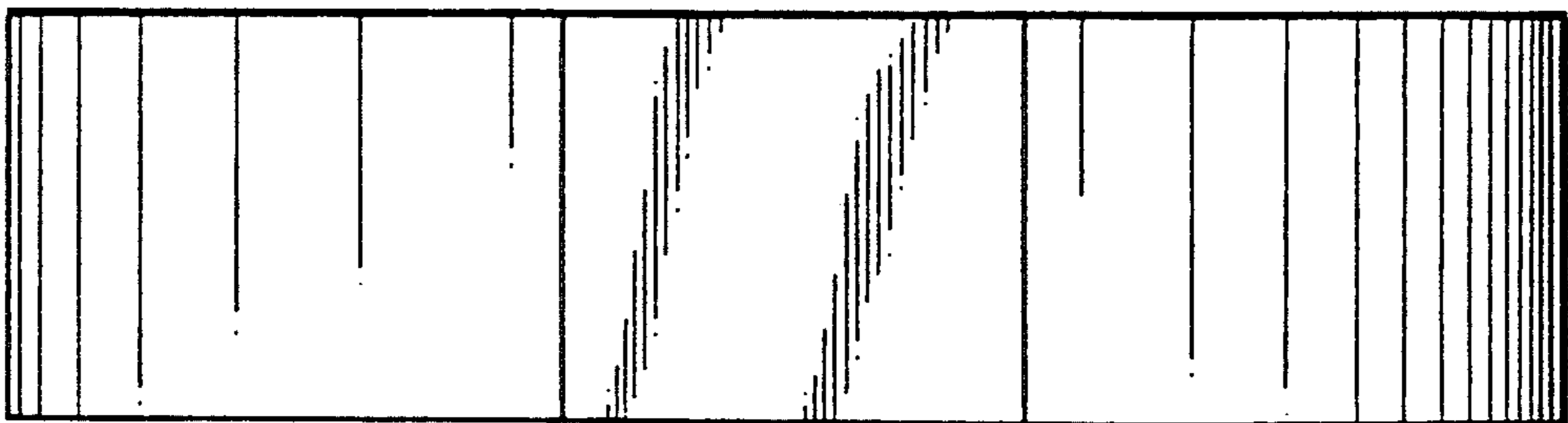

FIG. 2