



US00D327265S

# United States Patent [19]

[11] Patent Number: **Des. 327,265**

Jasey

[45] Date of Patent: **\*\* Jun. 23, 1992**

[54] **HEADPHONE FOR VEHICLE CELLULAR EQUIPAGE**

[76] Inventor: **Brian K. Jasey, P.O. Box 22620, Newark, N.J. 07101**

[\*\*] Term: **14 Years**

[21] Appl. No.: **570,367**

[22] Filed: **Aug. 21, 1990**

[52] U.S. Cl. .... **D14/138; D14/205; D14/204**

[58] Field of Search ..... **D14/253, 137, 223, 147, D14/142, 248, 138, 205, 206; 379/433, 430, 61; 381/183**

[56] **References Cited**

**U.S. PATENT DOCUMENTS**

D. 203,677	2/1966	Spilman et al. ....	D14/253 X
D. 292,400	10/1987	Boggs et al. ....	D14/147
D. 299,643	1/1989	Kubota .....	D14/223 X
D. 302,429	1/1989	Leer .....	D14/137 X
D. 305,759	1/1990	Belbuena .....	D14/223 X
D. 306,725	3/1990	Tanaka .....	D14/147
D. 316,551	4/1991	Ichikawa .....	D14/223 X
D. 320,605	10/1991	Chan .....	D14/248 X
4,175,217	10/1979	Williams .....	379/430
4,484,029	12/1984	Kenney .....	379/61

4,649,570	3/1987	Terbrack et al. ....	D14/223 X
4,691,383	9/1987	DeMars .....	379/430 X
4,754,484	6/1988	Larkin et al. ....	D14/142 X
4,821,318	4/1989	Wu .....	379/433 X
4,875,233	10/1989	Derhaag et al. ....	D14/223 X
4,882,745	11/1989	Silver .....	D14/223 X
4,993,065	2/1991	Chibu .....	379/430 X
5,003,589	3/1991	Chen .....	379/430 X

**FOREIGN PATENT DOCUMENTS**

0144130	7/1986	Japan .....	379/61
---------	--------	-------------	--------

*Primary Examiner*—Horace B. Fay, Jr.  
*Attorney, Agent, or Firm*—Terry M. Gernstein

[57] **CLAIM**

The ornamental design for a headphone for vehicle cellular equipage, as shown and described.

**DESCRIPTION**

FIG. 1 is a left side, top and front perspective view of a headphone for vehicle cellular equipage showing my new design; FIGS. 2 and 3 are respectively front and rear elevational views thereof; FIGS. 4 and 5 are respectively left and right side elevational views thereof; and, FIGS. 6 and 7 are respectively top and bottom plan views thereof.

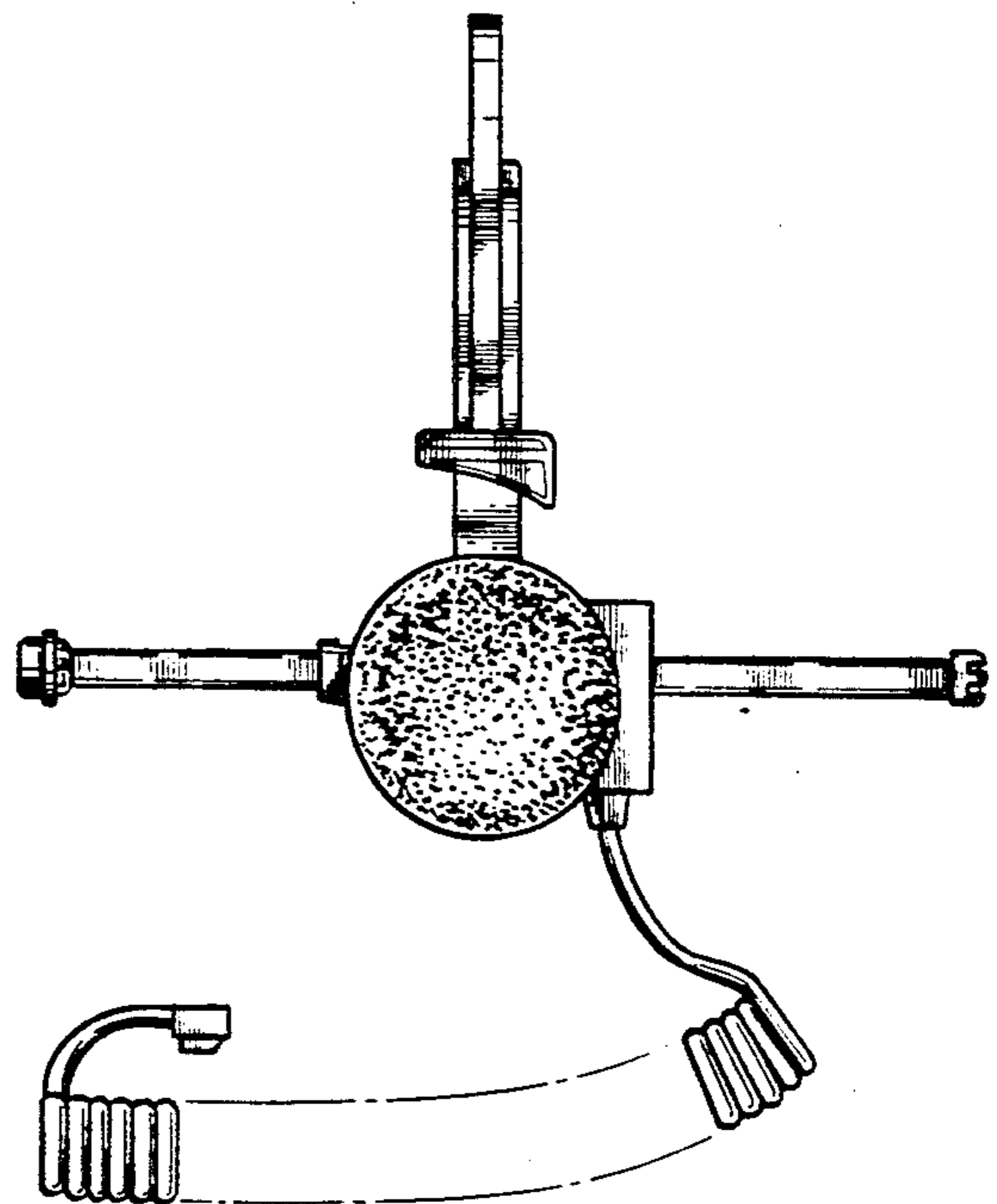
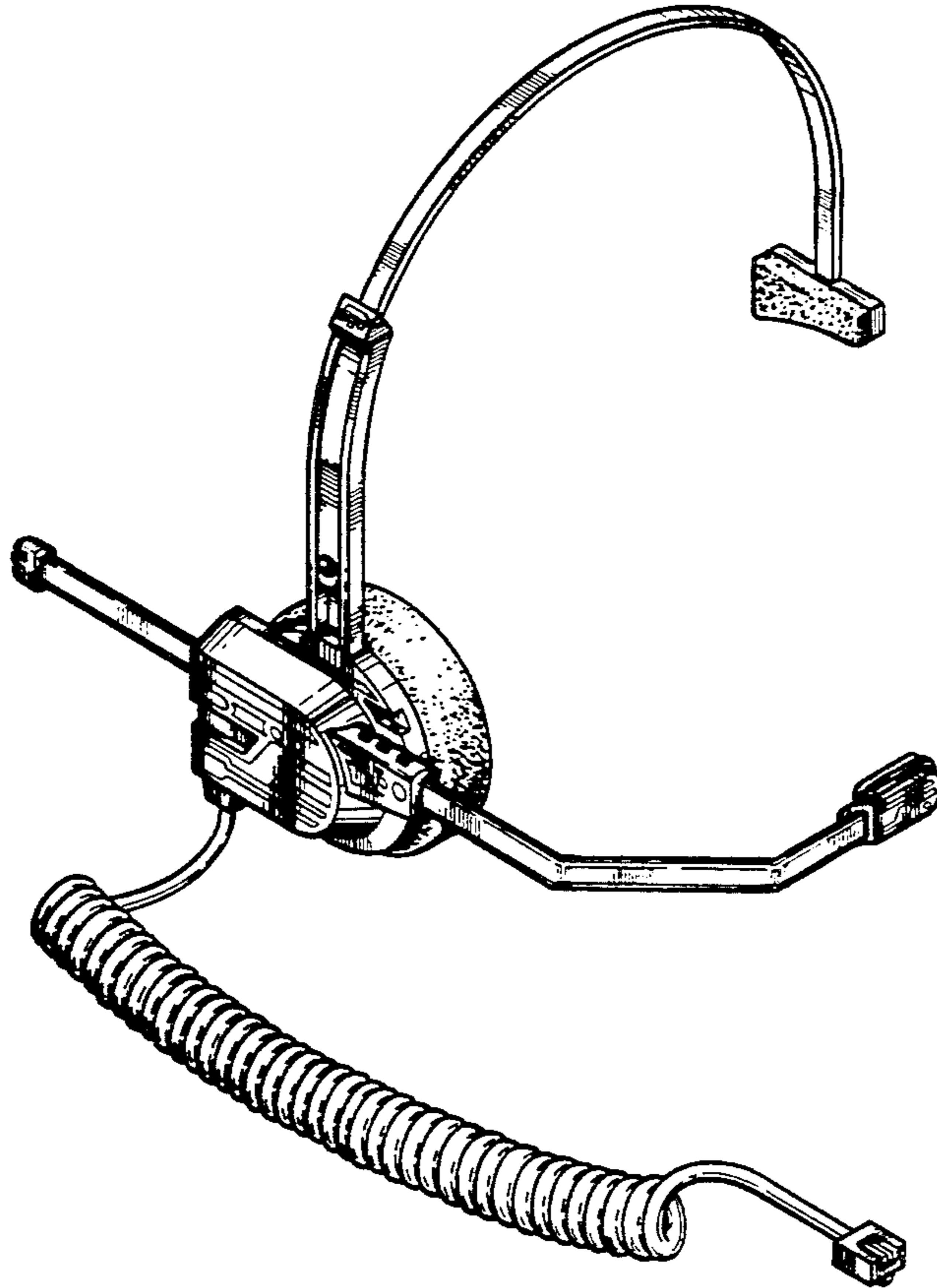

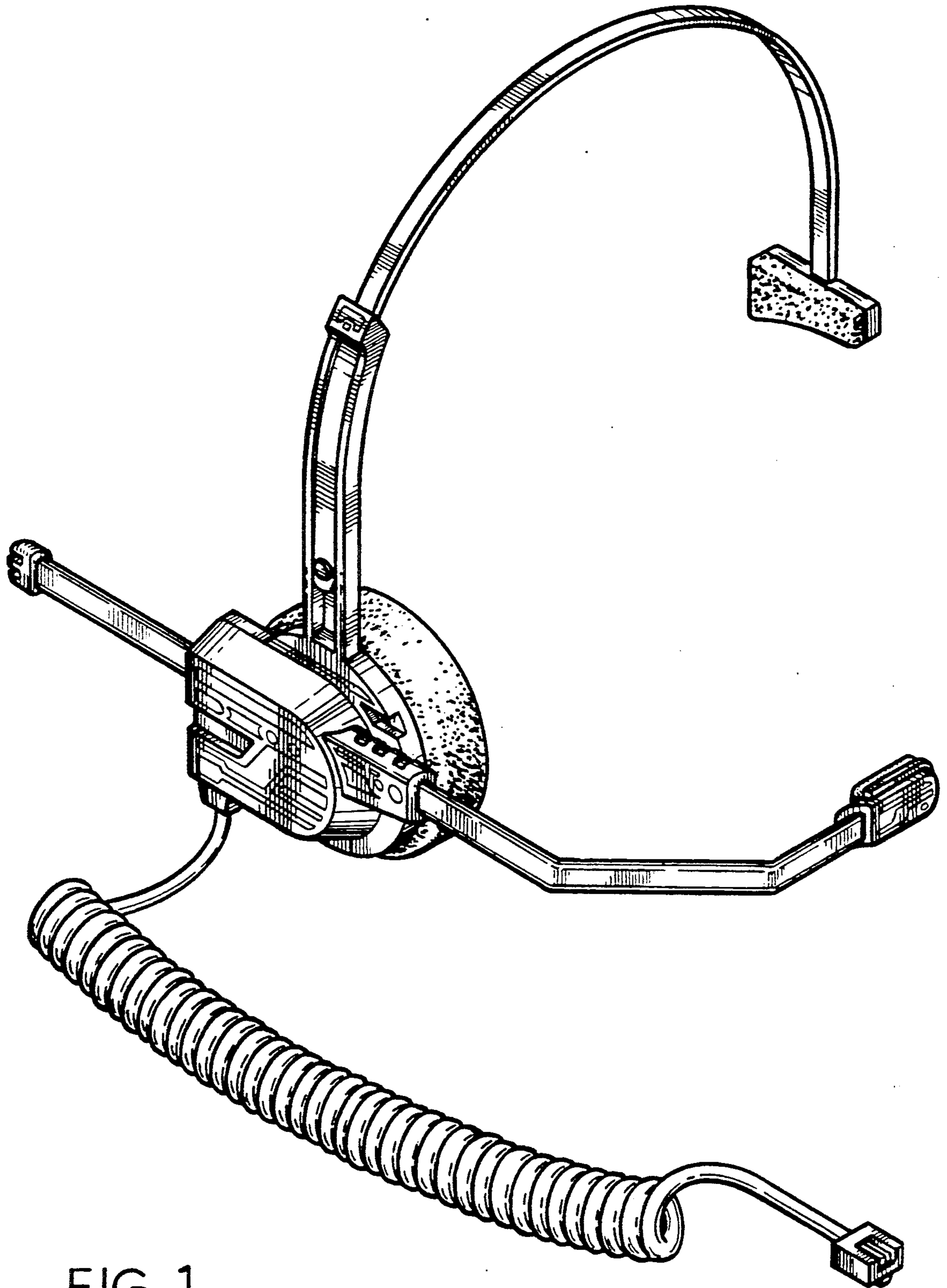

FIG. 1

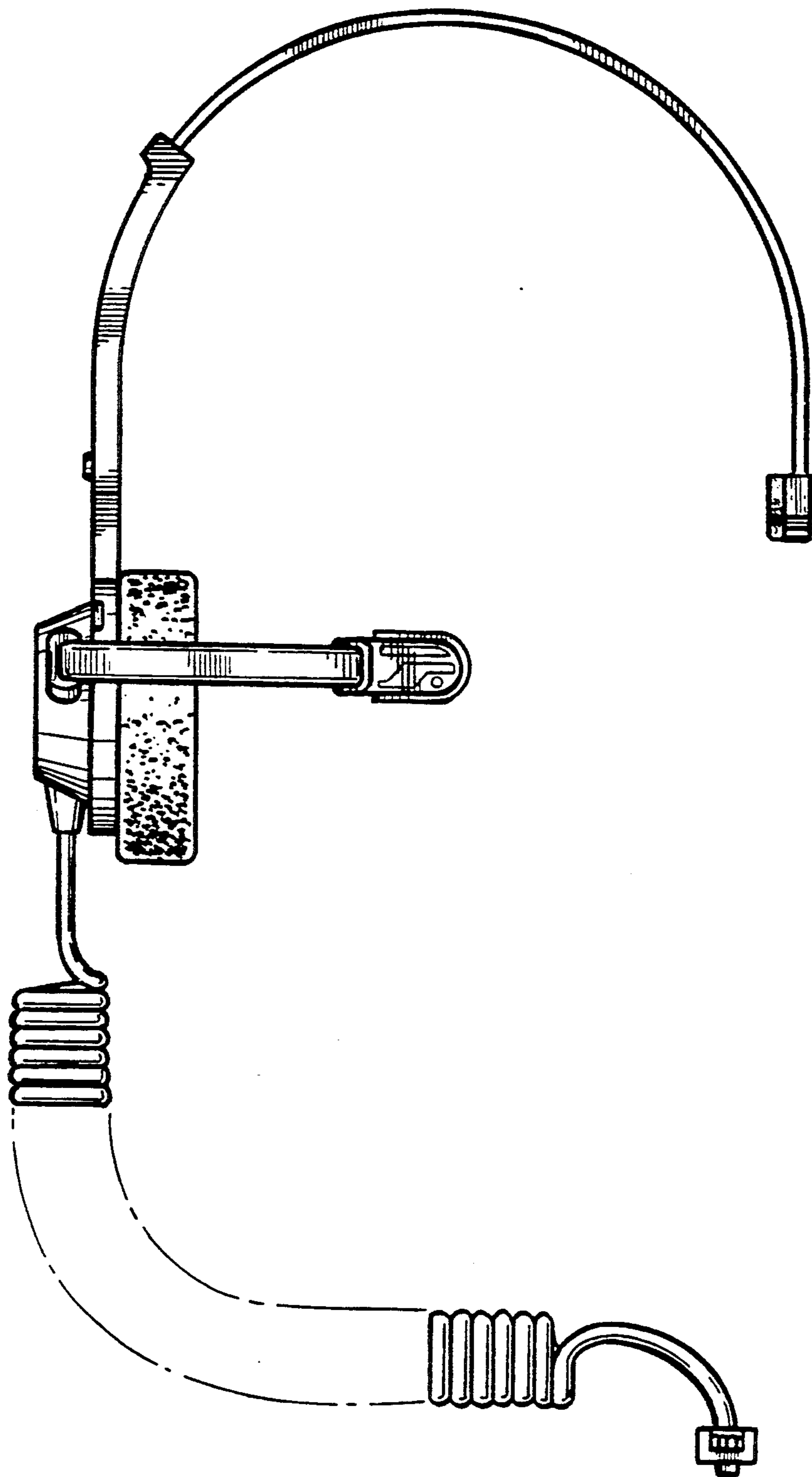

FIG. 2

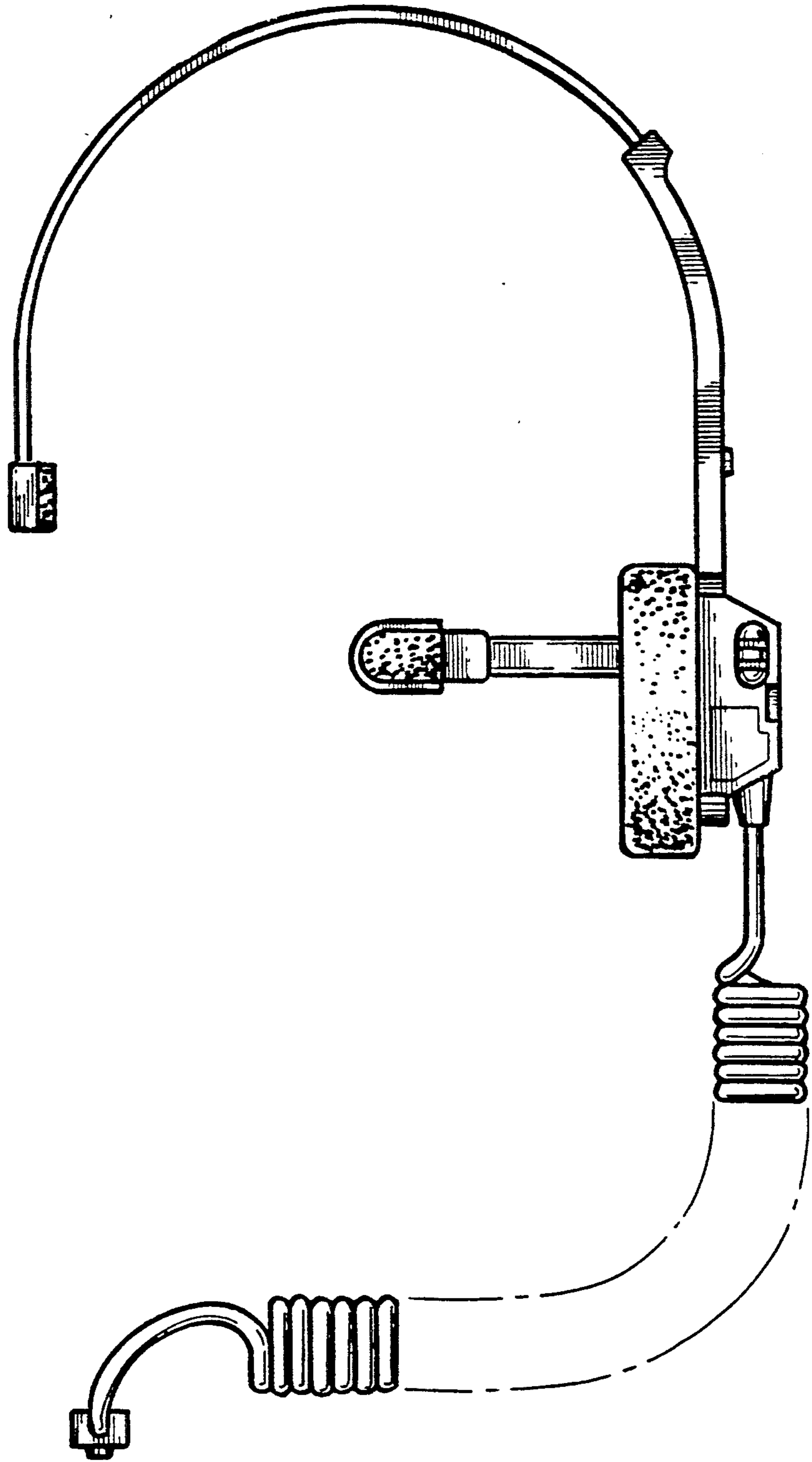

FIG. 3

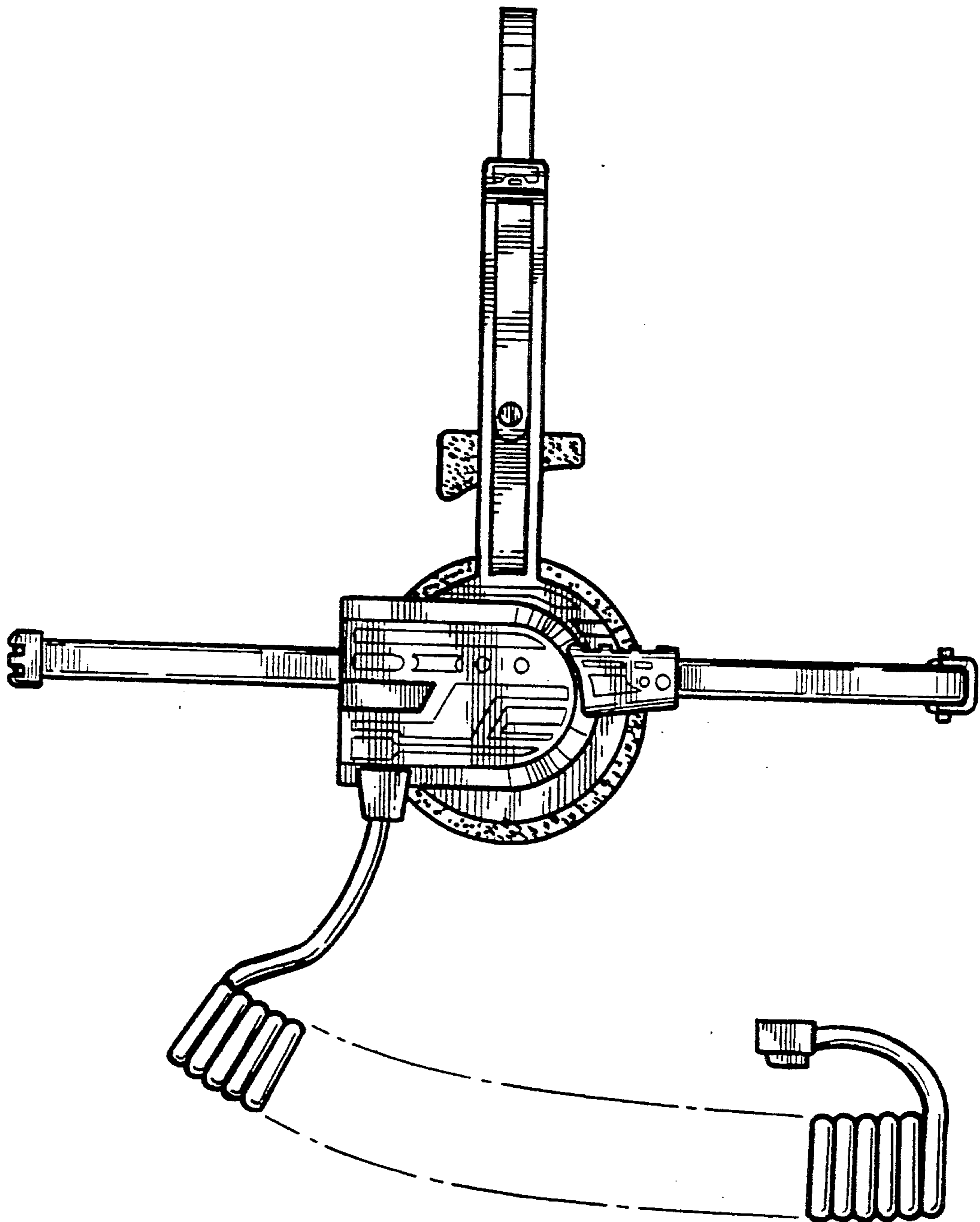

FIG. 4

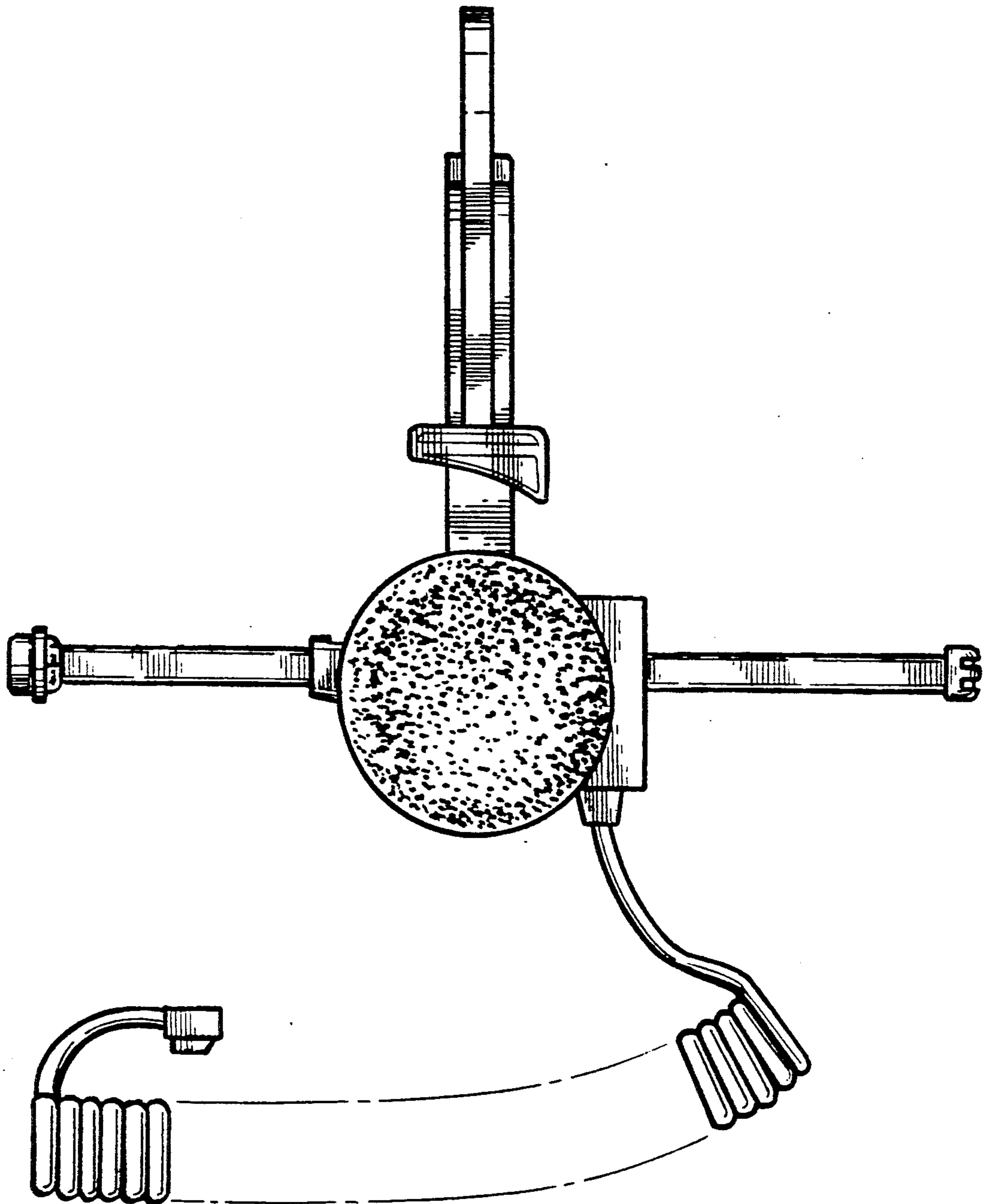

FIG. 5

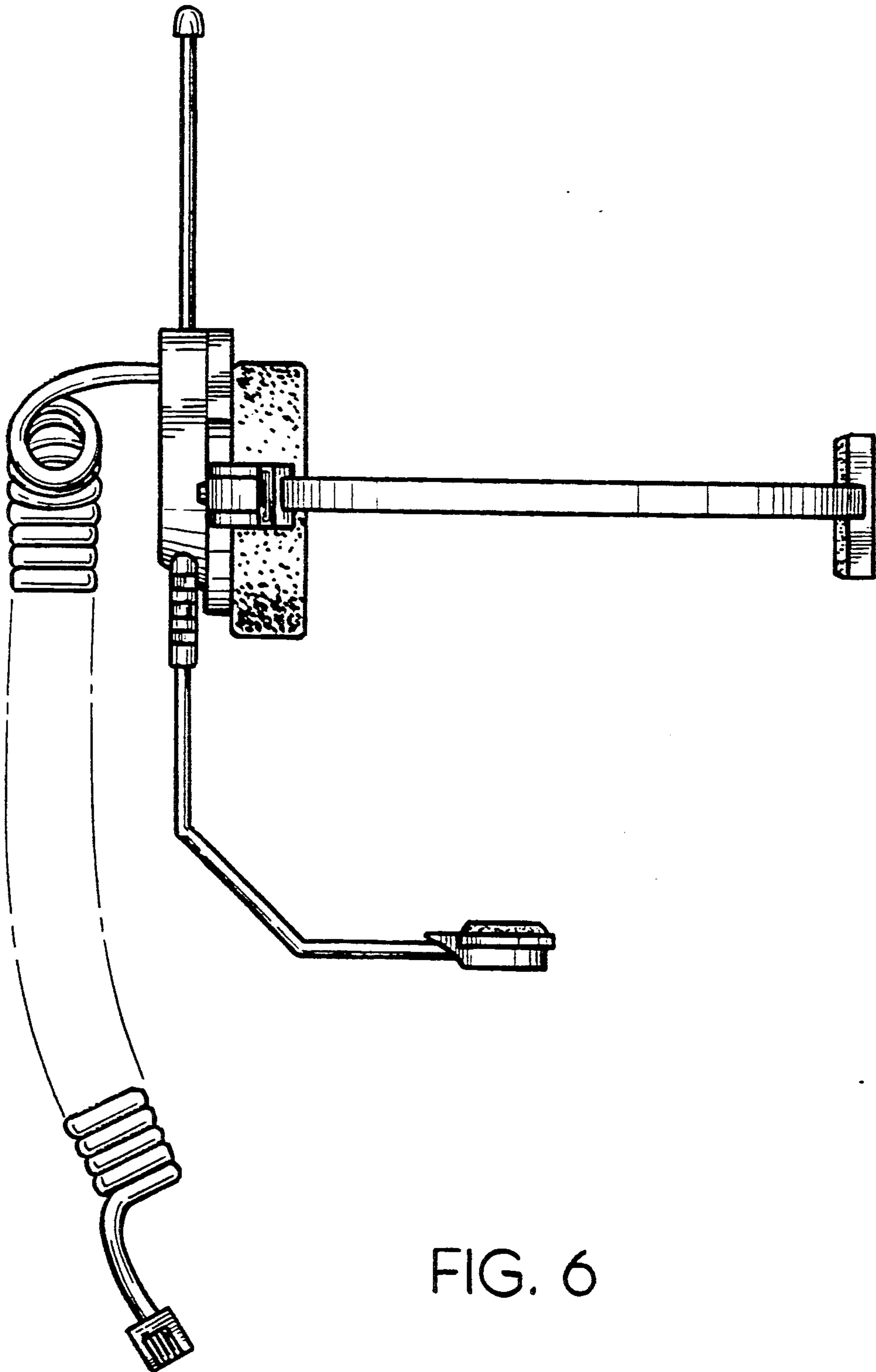

FIG. 6

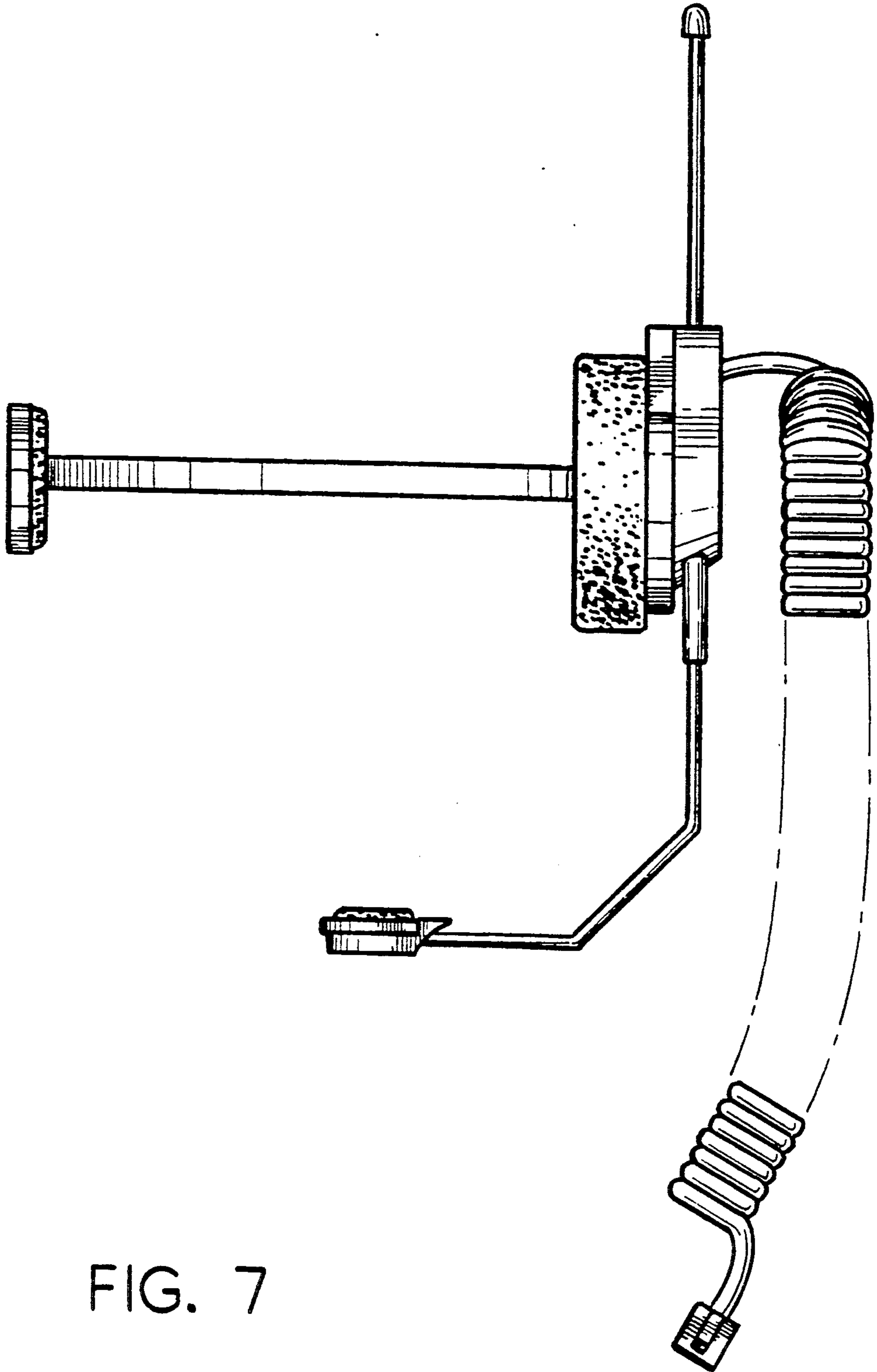

FIG. 7