



US00D327239S

United States Patent [19]

[11] Patent Number: **Des. 327,239**

Ui et al.

[45] Date of Patent: **** Jun. 23, 1992**

[54] **AUTOMOBILE**

D. 318,636 7/1991 Shimoyama et al. D12/92

[75] Inventors: **Yoshio Ui, Saitama; Yusuke Saitoh; Mashiko Sugiyama, both of Tokyo, all of Japan**

OTHER PUBLICATIONS

Motor Trend, May 1988, p. 28, Ford Sierra RS Cosworth Notchback Automobile, center of page.

[73] Assignee: **Honda Giken Kogyo Kabushiki Kaisha, Tokyo, Japan**

Motor Trend, Jul. 1988, p. 24, Opel Vectra Automobile, bottom left side of page.

[**] Term: **14 Years**

Motor Trend, Oct. 1988, p. 30, Cadillac Eldorado LSS, top of page.

[21] Appl. No.: **635,780**

Primary Examiner—James M. Gandy

[22] Filed: **Dec. 28, 1990**

Attorney, Agent, or Firm—Lyon & Lyon

[30] **Foreign Application Priority Data**

[57] **CLAIM**

Aug. 24, 1990 [JP] Japan 2-28411

The ornamental design for an automobile, as shown.

[52] U.S. Cl. **D12/92**

DESCRIPTION

[58] Field of Search D12/91, 92; 296/185

FIG. 1 is a left side elevation view of an automobile showing our new design;

[56] **References Cited**

FIG. 2 is a right side elevation view thereof;

U.S. PATENT DOCUMENTS

D. 301,848 6/1989 Kurosu et al. D12/92

FIG. 3 is a top plan view thereof;

D. 317,887 7/1991 Shimoyama et al. D12/92

FIG. 4 is a front elevation view thereof; and,

FIG. 5 is a rear elevation view thereof.

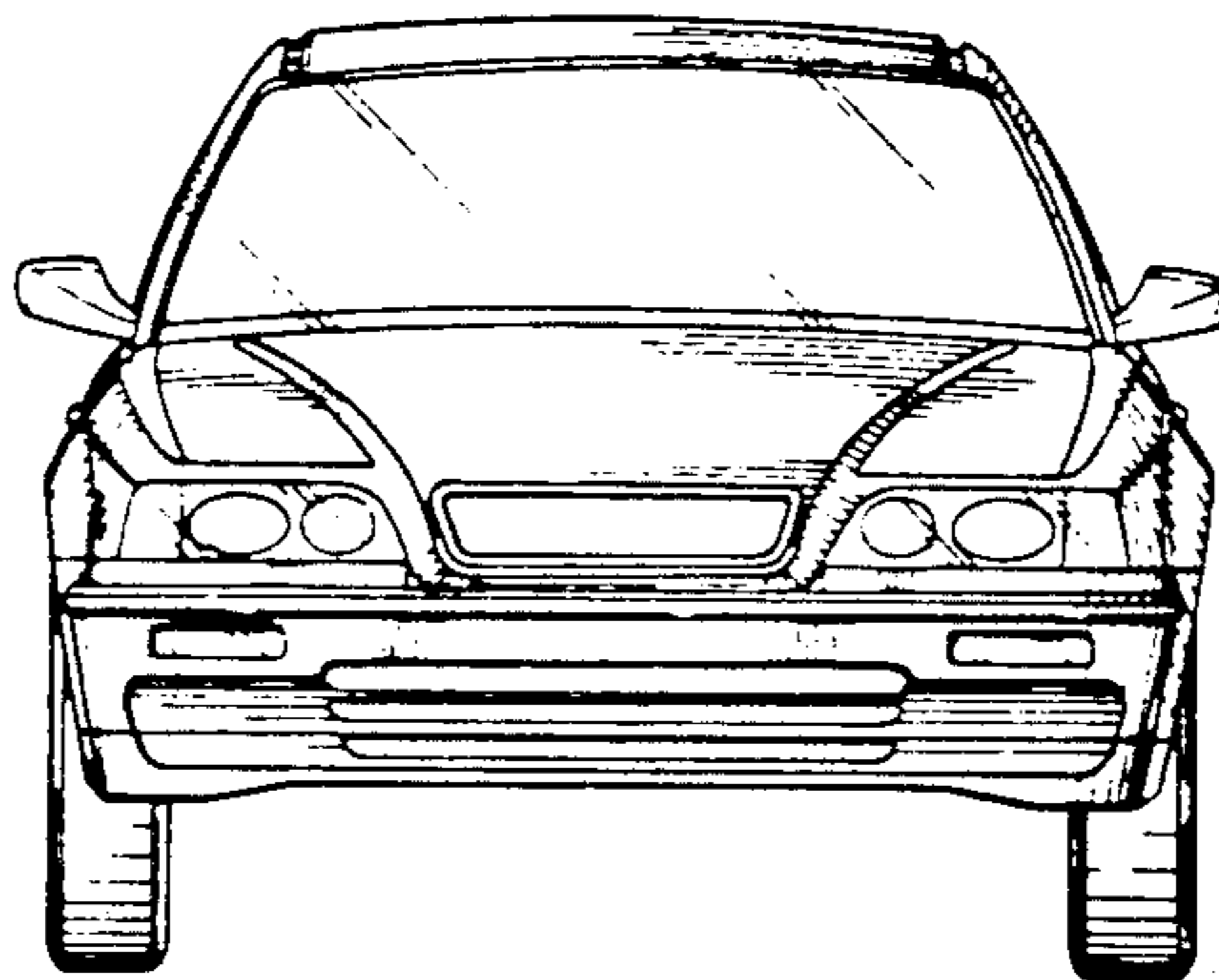
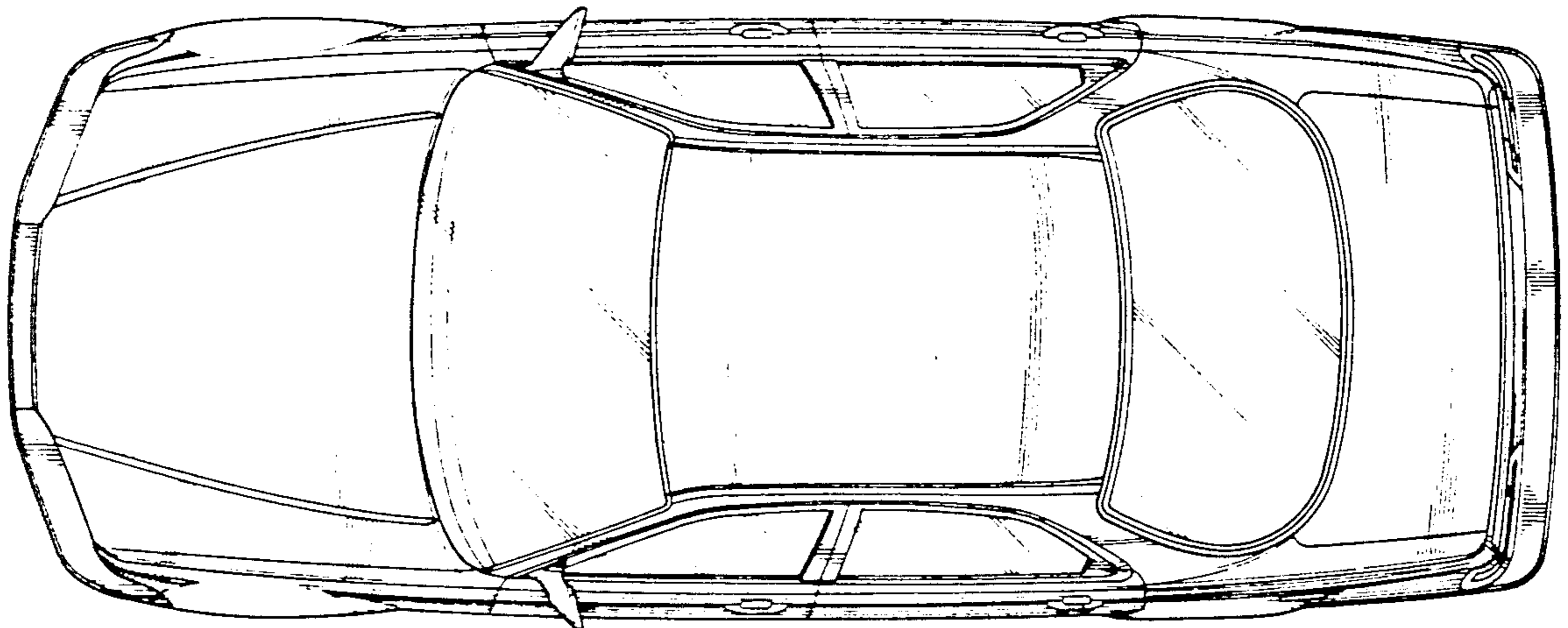

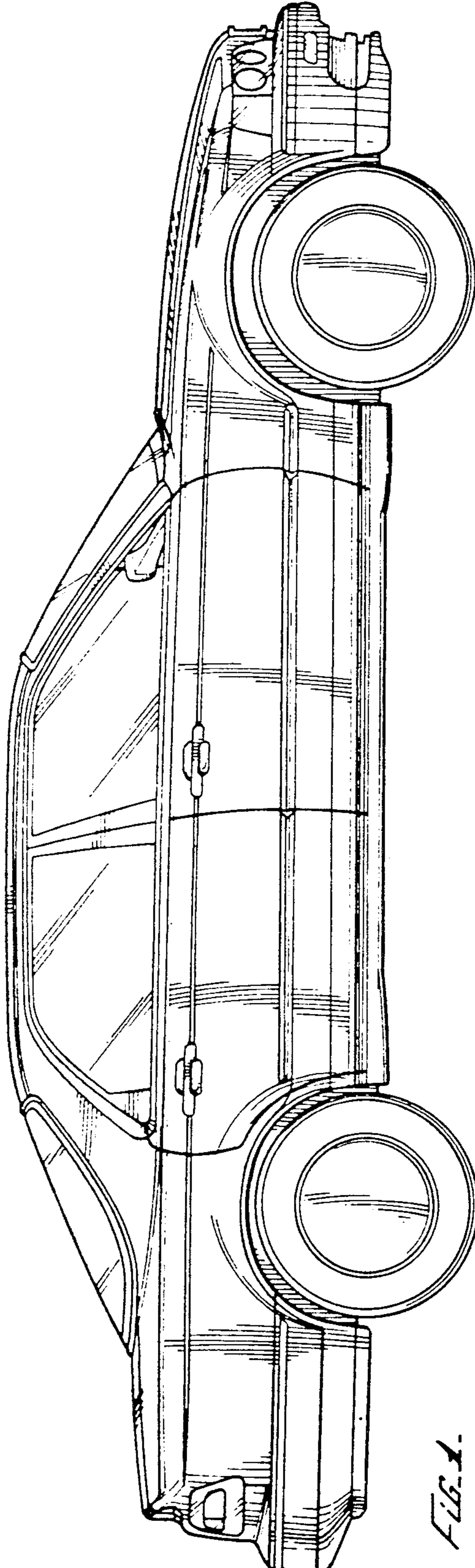

FIG. 1.

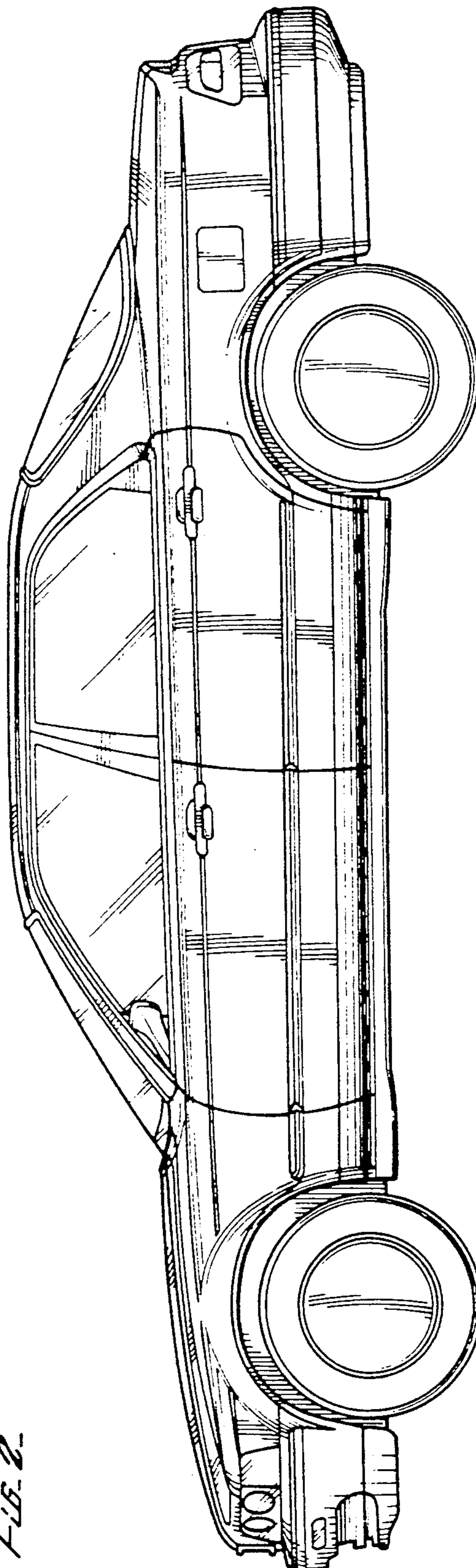

FIG. 2.

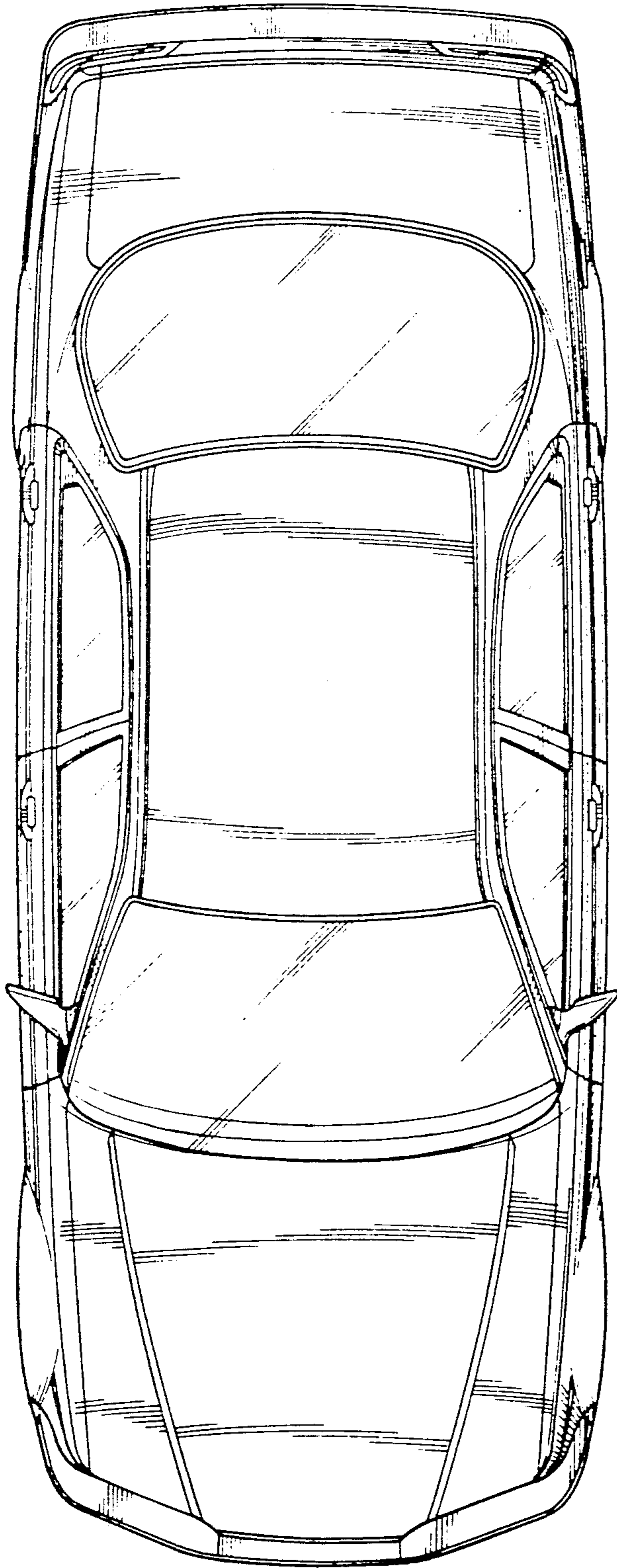

FIG. 3.

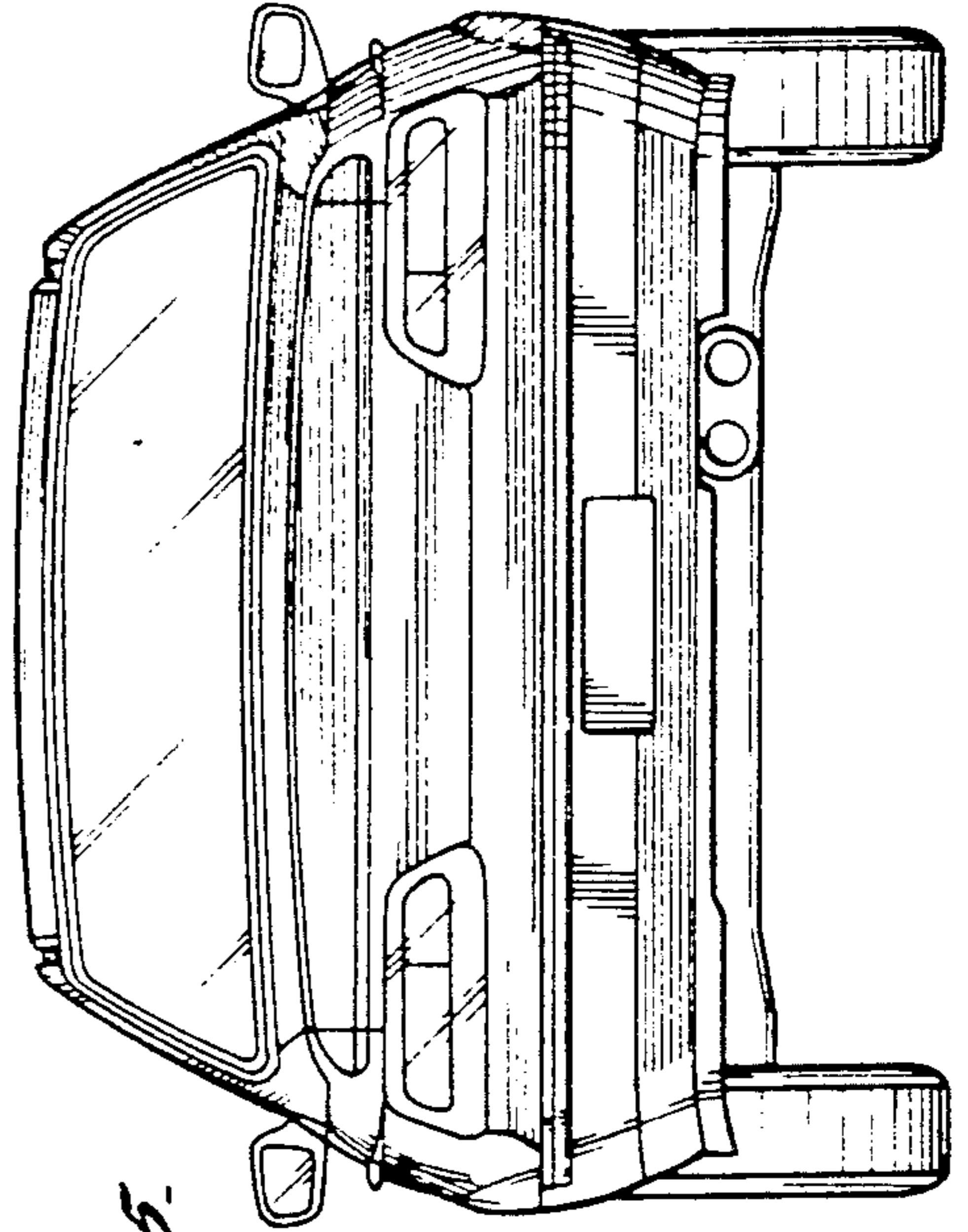

FIG. 5.

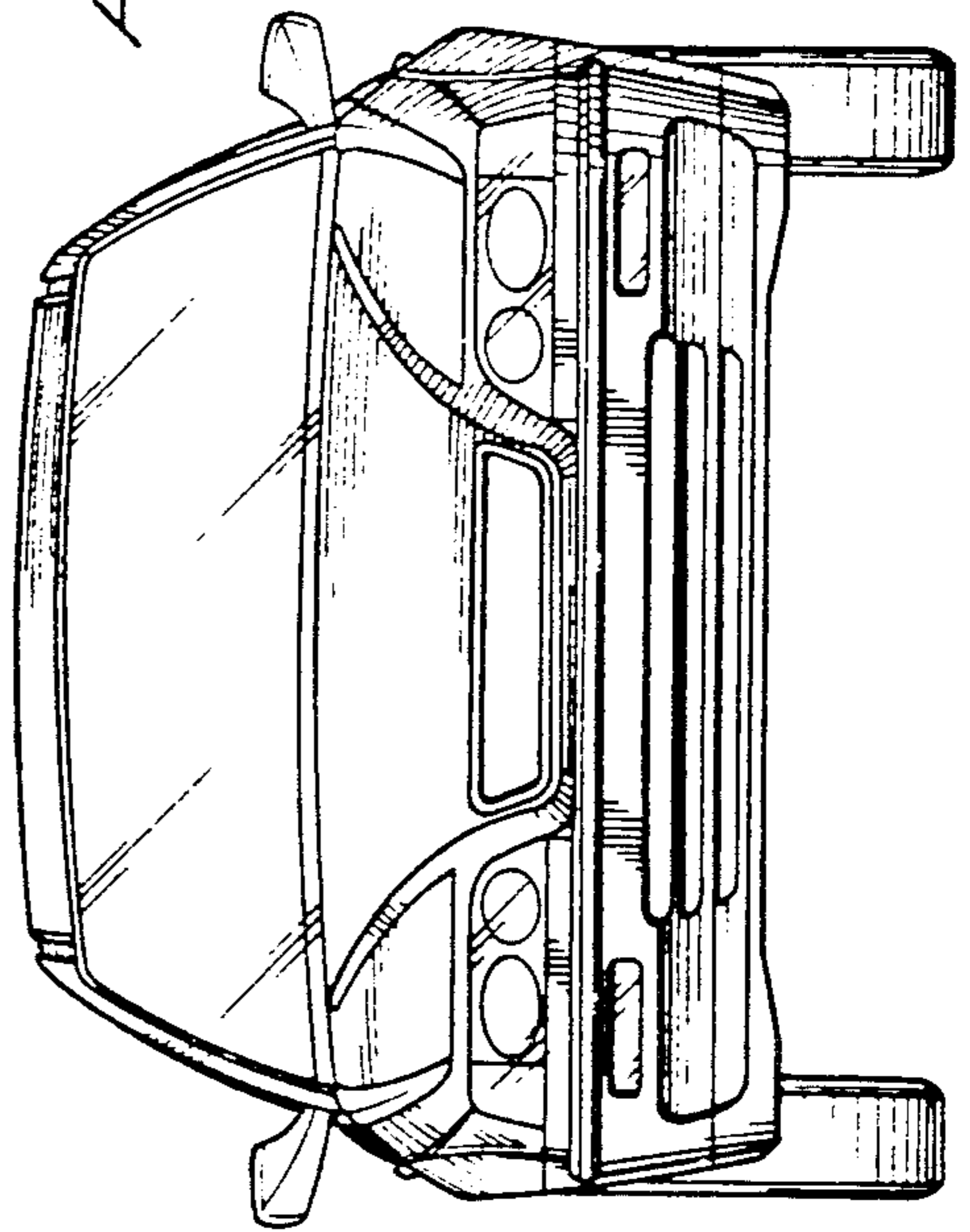

FIG. 4.