



US00D327237S

United States Patent [19]

[11] Patent Number: **Des. 327,237**

Miyamoto et al.

[45] Date of Patent: **** Jun. 23, 1992**

[54] OFF ROAD VEHICLE

[56] References Cited

[75] Inventors: **Shiro Miyamoto**, Torrance; **Kazuhiko Saito**, Rancho Palos Verdes; **Yutaka Kawasaki**, Redondo Beach, all of Calif.; **Tetsuya Nakazawa**, Saitama, Japan

U.S. PATENT DOCUMENTS

D. 286.760 11/1986 Ooba et al. D12/87

[73] Assignee: **Honda R&D North America, Inc.**, Torrance, Calif.

OTHER PUBLICATIONS

Popular Mechanics, Mar. 1977, p. 93, Paul Howes's Homebuilt Vehicle, upper left side of page.

[**] Term: **14 Years**

Primary Examiner—James M. Gandy

[21] Appl. No.: **410,241**

[57] **CLAIM**

The ornamental design for an off road vehicle, as shown and described.

[22] Filed: **Sep. 21, 1989**

DESCRIPTION

[52] U.S. Cl. **D12/87**

FIG. 1 is a perspective view of an off road vehicle showing my new design;

[58] Field of Search **D12/87, 91, 92, 1;**

FIG. 2 is a top plan view thereof;

FIG. 3 is a left side elevational view thereof;

FIG. 4 is a right side elevational view thereof;

FIG. 5 is a front elevational view thereof; and,

FIG. 6 is a rear elevational view thereof.

296/185, 186

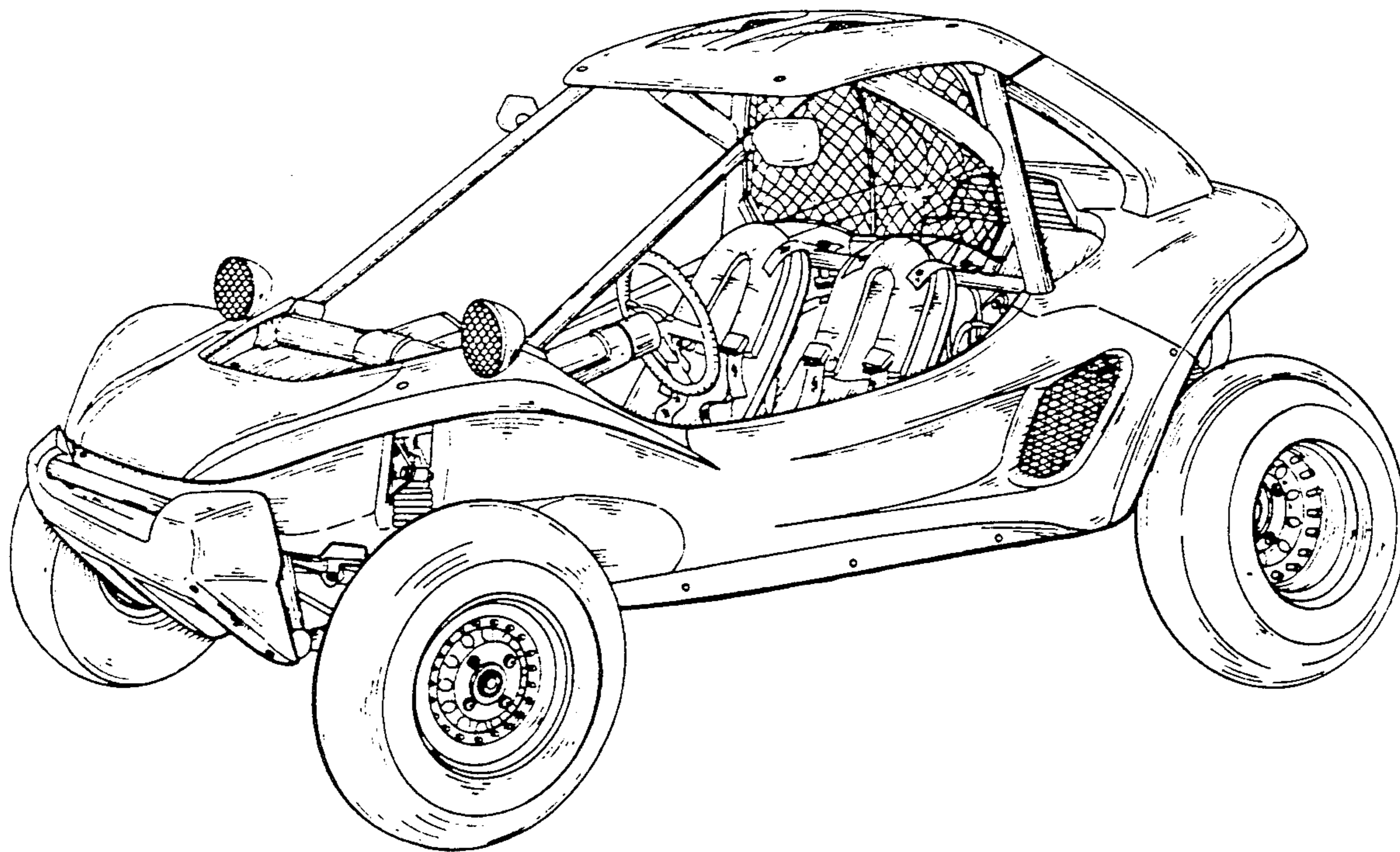

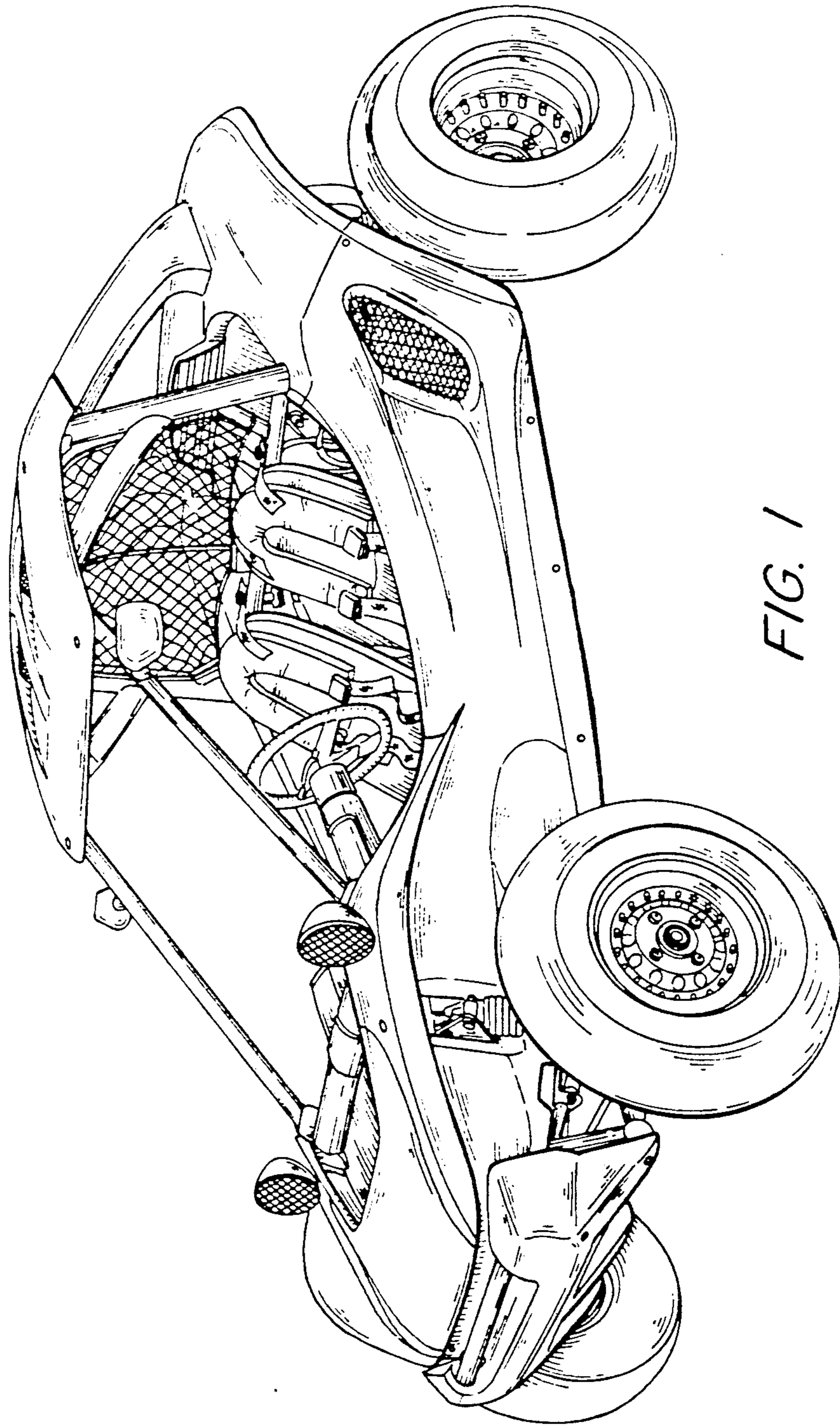

FIG. 1

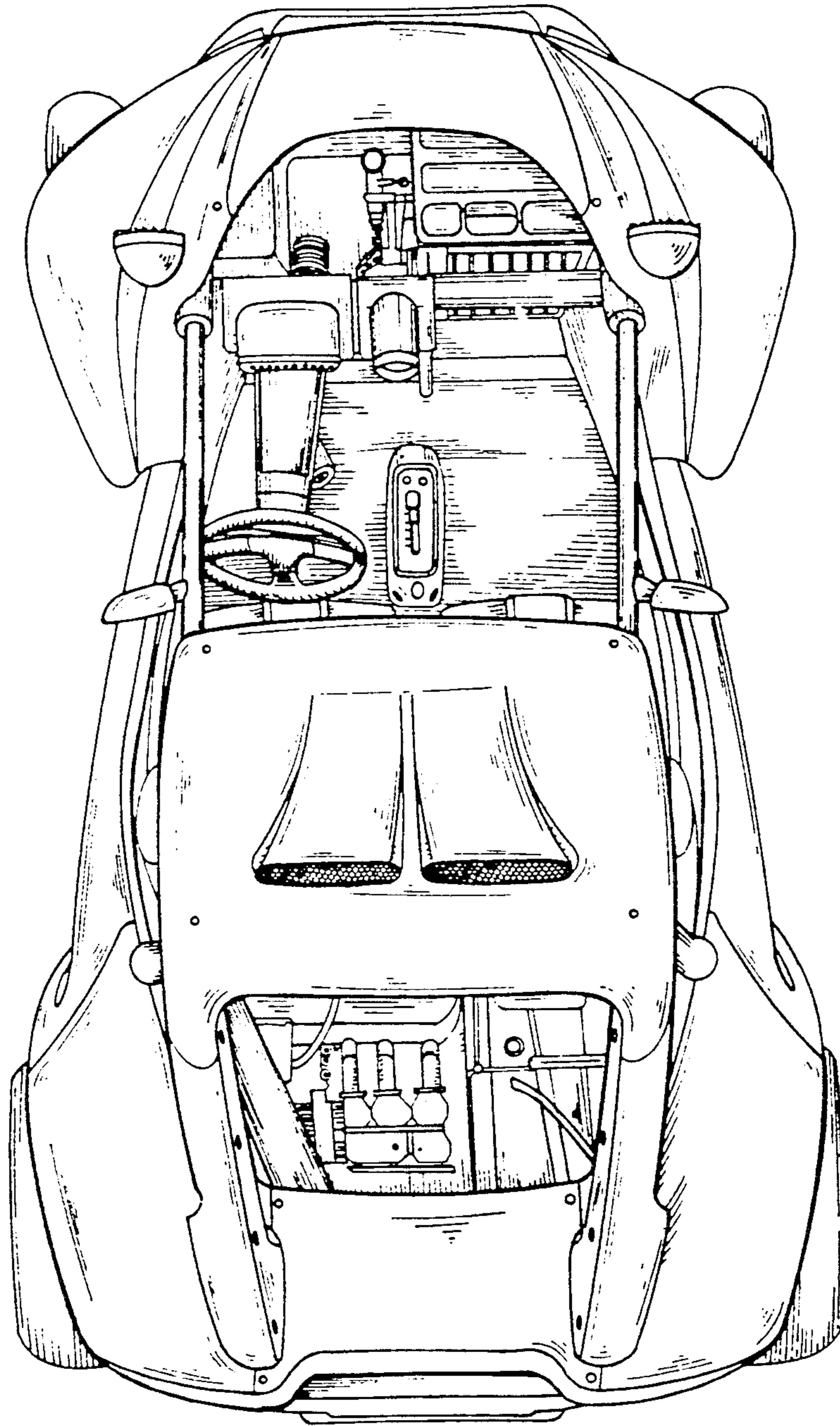

FIG. 2

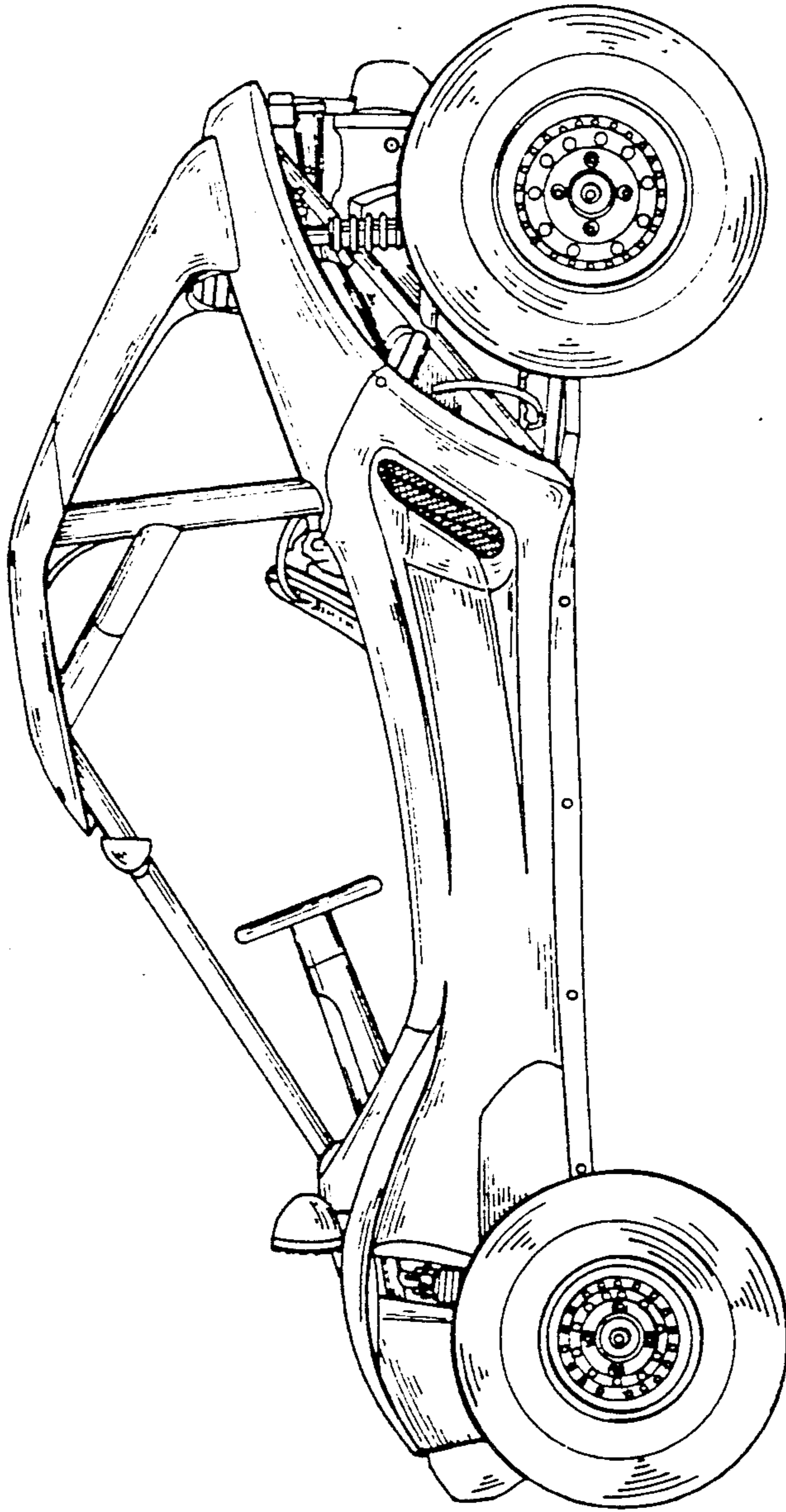

FIG. 3

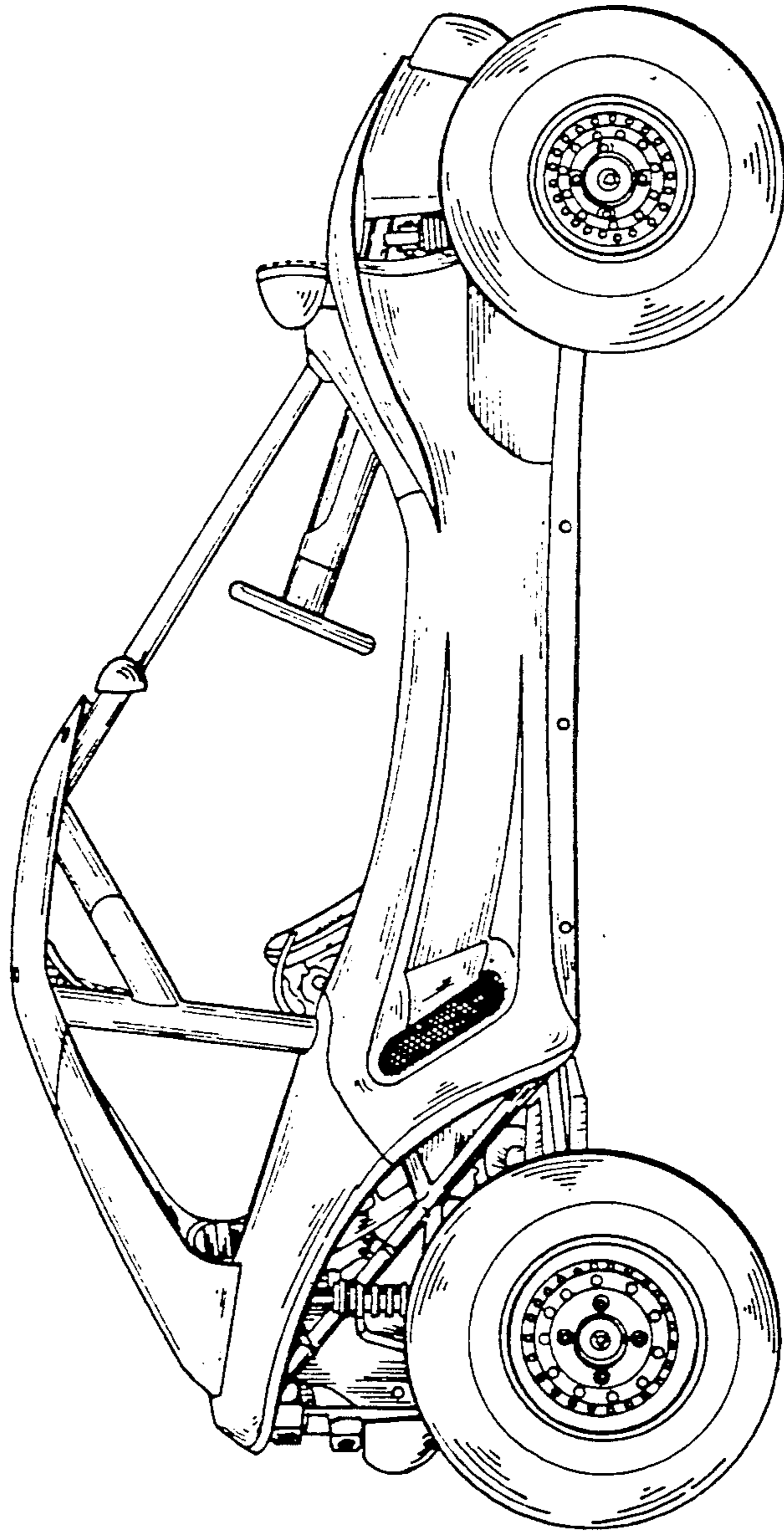

FIG. 4

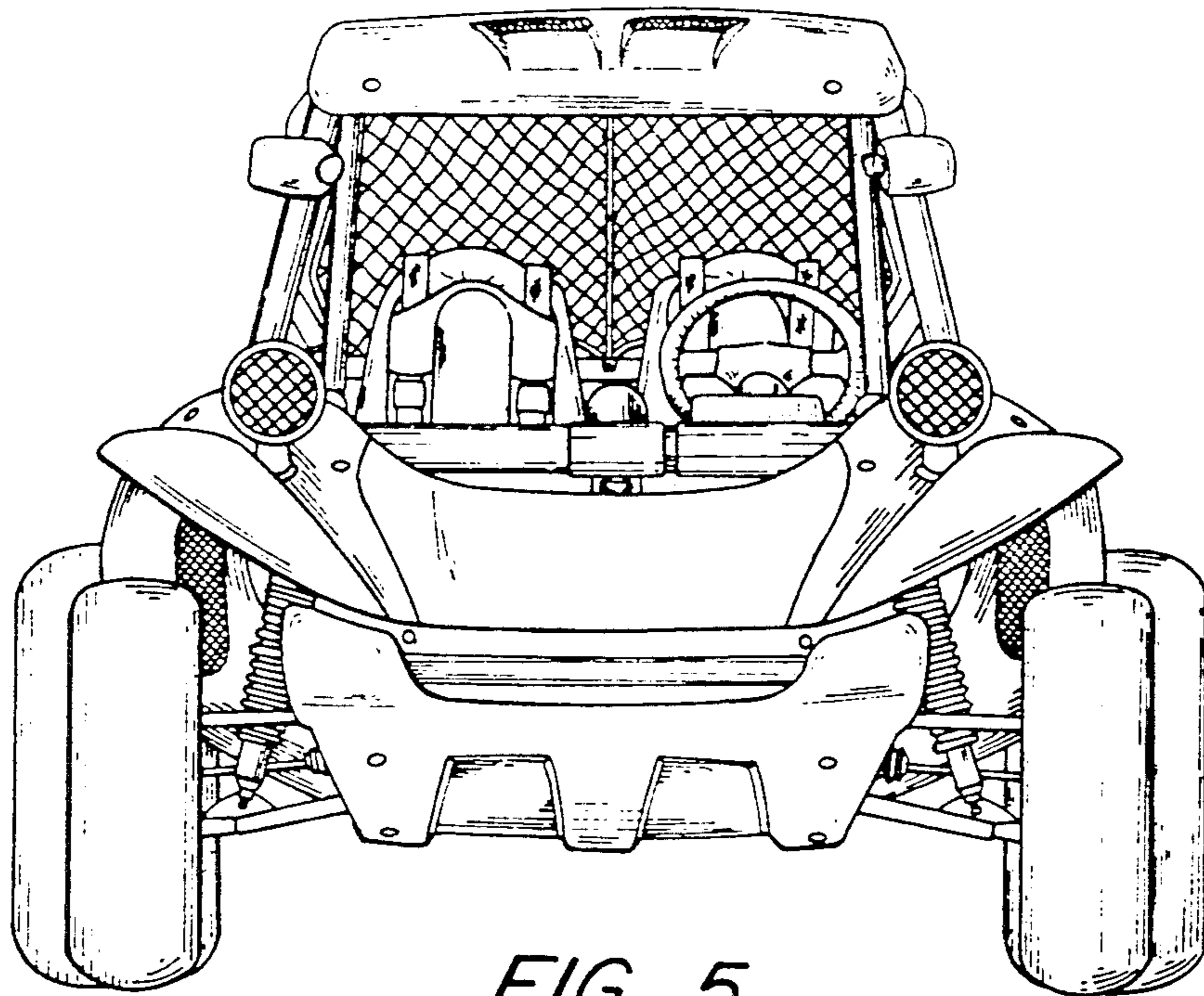

FIG. 5

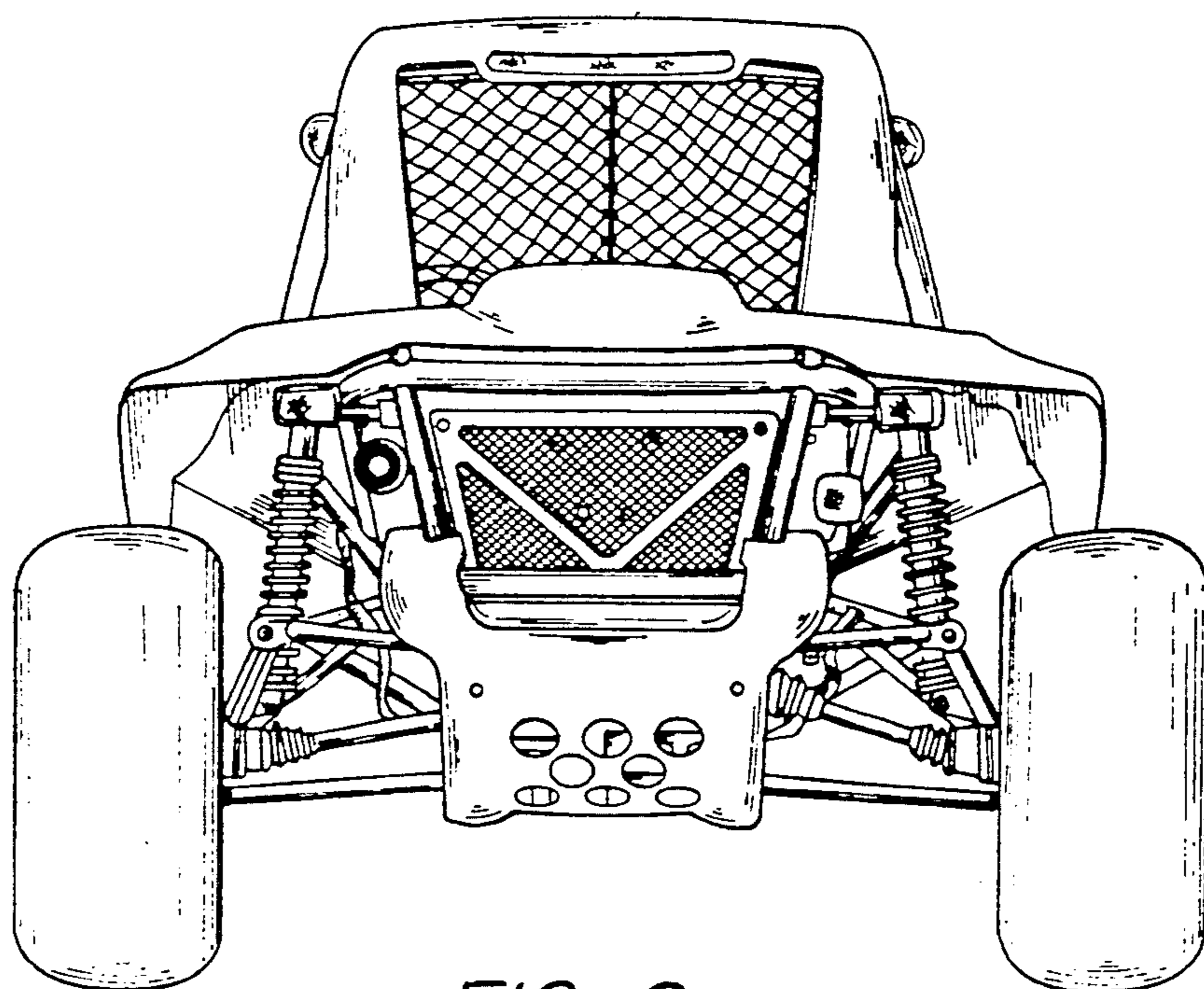

FIG. 6