



US00D327102S

United States Patent [19]

[11] Patent Number: **Des. 327,102**

Martin

[45] Date of Patent: **** Jun. 16, 1992**

[54] TOY MARKET CHECKOUT STAND

4,138,000 2/1979 Hartup D6/402

[76] Inventor: **Cynthia Martin**, 106 Bowman,
Harrisonville, Mo. 64701

4,458,440 7/1984 D'Andrade .

4,696,652 9/1987 Reeder .

4,973,287 11/1990 Martin 446/479

[**] Term: **14 Years**

Primary Examiner—Charles A. Rademaker
Attorney, Agent, or Firm—Terry M. Gernstein

[21] Appl. No.: **462,445**

[57] CLAIM

[22] Filed: **Jan. 9, 1990**

The ornamental design for a toy market checkout stand,
as shown and described.

[52] U.S. Cl. **D21/109**

[58] Field of Search D21/59, 109, 111, 124;
D6/402; 446/424, 483, 491, 479, 143, 129

DESCRIPTION

[56] References Cited

U.S. PATENT DOCUMENTS

D. 118,817	2/1940	Gill	D6/402
D. 216,232	12/1969	Stackhouse	D6/402
D. 252,292	7/1979	Johnson	.	
D. 312,106	11/1990	Kolker	D21/109
1,016,208	1/1912	Cass	.	
1,440,944	1/1923	Tarr	.	

FIG. 1 is a perspective view of a toy market checkout stand showing my new design;
FIG. 2 is an end elevational view thereof;
FIG. 3 is a side elevational view thereof;
FIG. 4 is an end elevational view of the end opposite that shown in FIG. 2; and,
FIG. 5 is a top plan view thereof.
The unshown bottom of the design is substantially flat, plain and unornamented.

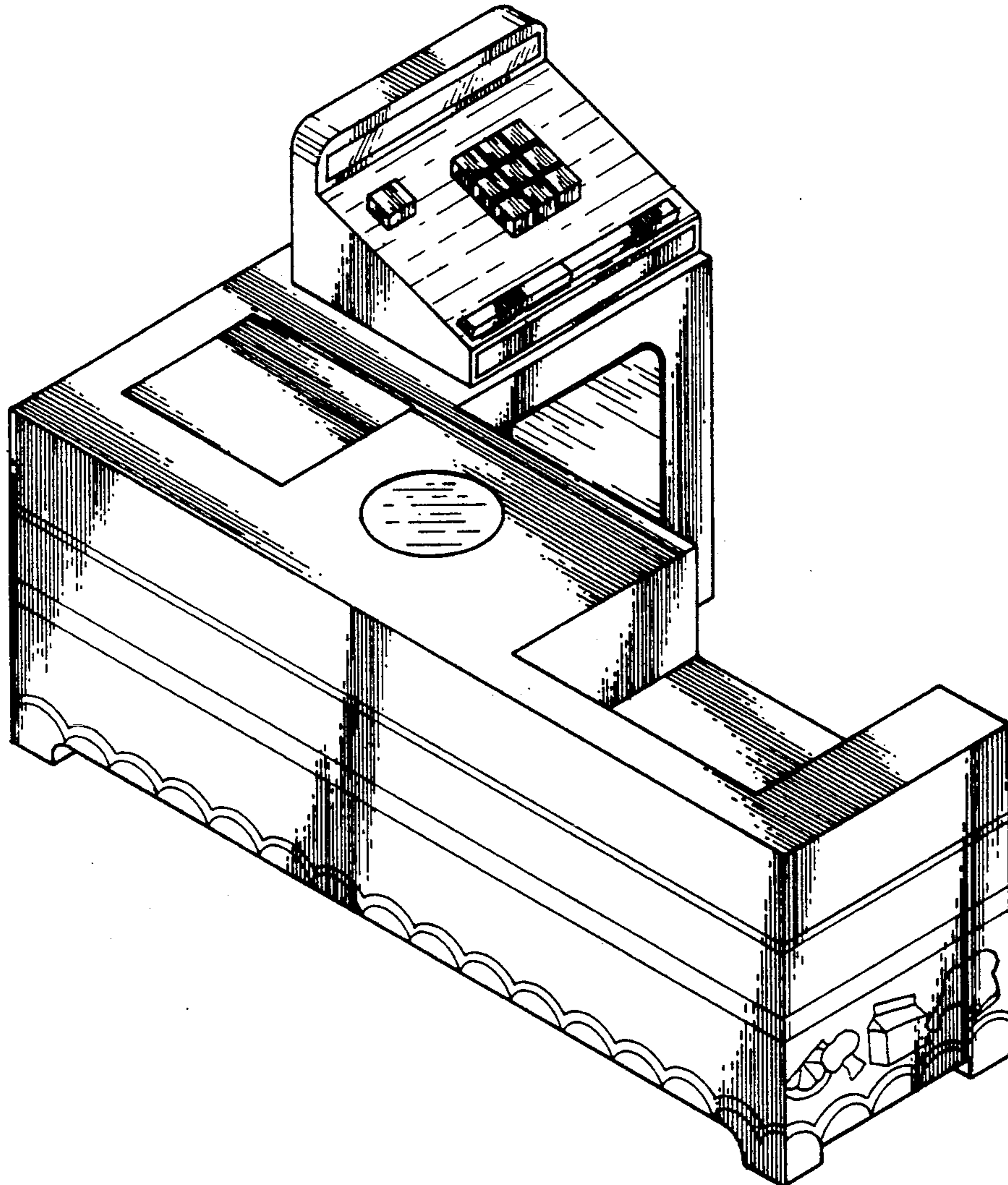

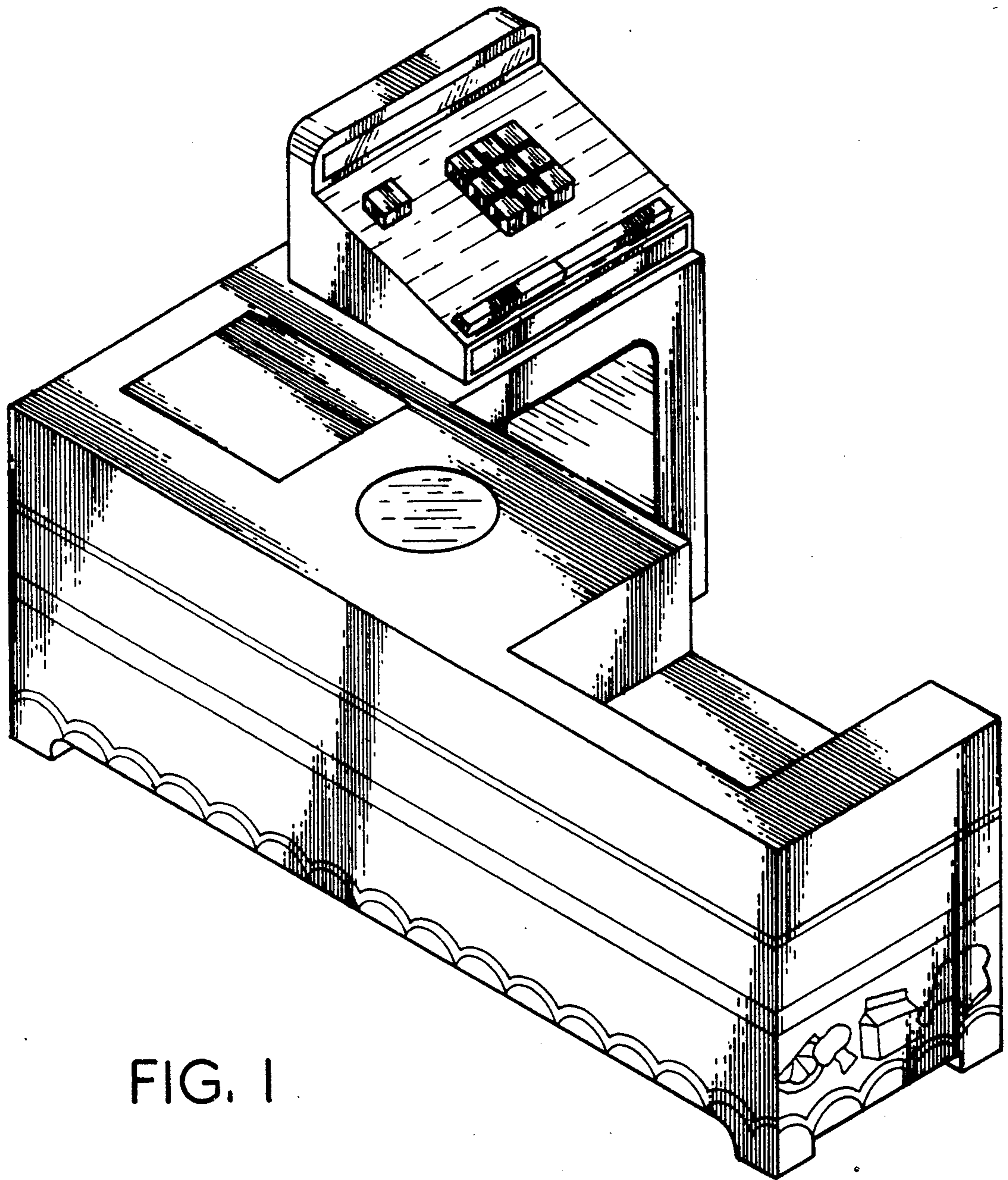

FIG. 1

