



US00D326878S

United States Patent [19]

Suzuki

[11] Patent Number: **Des. 326,878**

[45] Date of Patent: **** Jun. 9, 1992**

[54] **TOY VEHICLE OR SIMILAR ARTICLE**

[75] Inventor: **Toshio Suzuki, Tokyo, Japan**

[73] Assignee: **Kabushiki-Kaisha Toy Box, Tokyo, Japan**

[**] Term: **14 Years**

[21] Appl. No.: **603,643**

[22] Filed: **Oct. 25, 1990**

[30] **Foreign Application Priority Data**

May 10, 1990 [JP] Japan 2-15612

[52] U.S. Cl. **D21/128**

[58] Field of Search D21/128, 129, 131, 134, D21/135, 136, 137, 140; D12/1, 3, 14, 97; 446/94, 427, 433, 426, 460, 467

[56] **References Cited**

U.S. PATENT DOCUMENTS

D. 139,637 12/1944 Walker D12/97
D. 146,879 6/1947 Sebern D12/97

D. 202,505 10/1965 Johnson D21/129
D. 258,747 3/1981 Burtoft D21/128

OTHER PUBLICATIONS

Business Week Jun. 9, 1943, p. 97.

Primary Examiner—Theodore M. Shooman
Assistant Examiner—R. Barkai
Attorney, Agent, or Firm—Sughrue, Mion, Zinn, Macpeak & Seas

[57] **CLAIM**

An ornamental design for a toy vehicle or similar article, as shown.

DESCRIPTION

FIG. 1 is a front elevational view of a toy vehicle or similar article showing my new design;
FIG. 2 is a rear elevational view thereof;
FIG. 3 is a top plan view thereof;
FIG. 4 is a bottom plan view thereof;
FIG. 5 is a right side elevational view thereof;
FIG. 6 is a left side elevational view thereof; and,
FIG. 7 is a perspective view thereof.

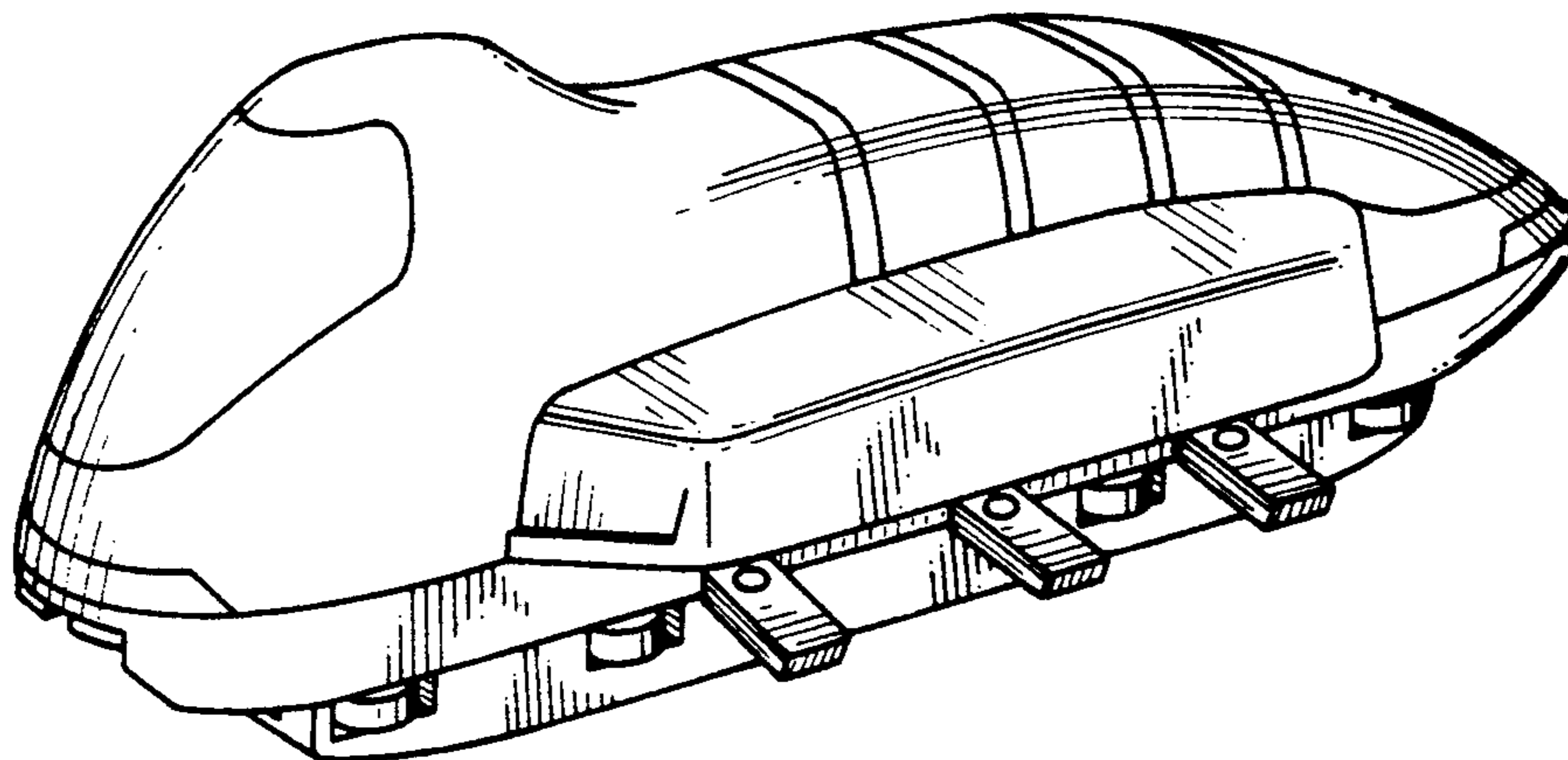

FIG. 1

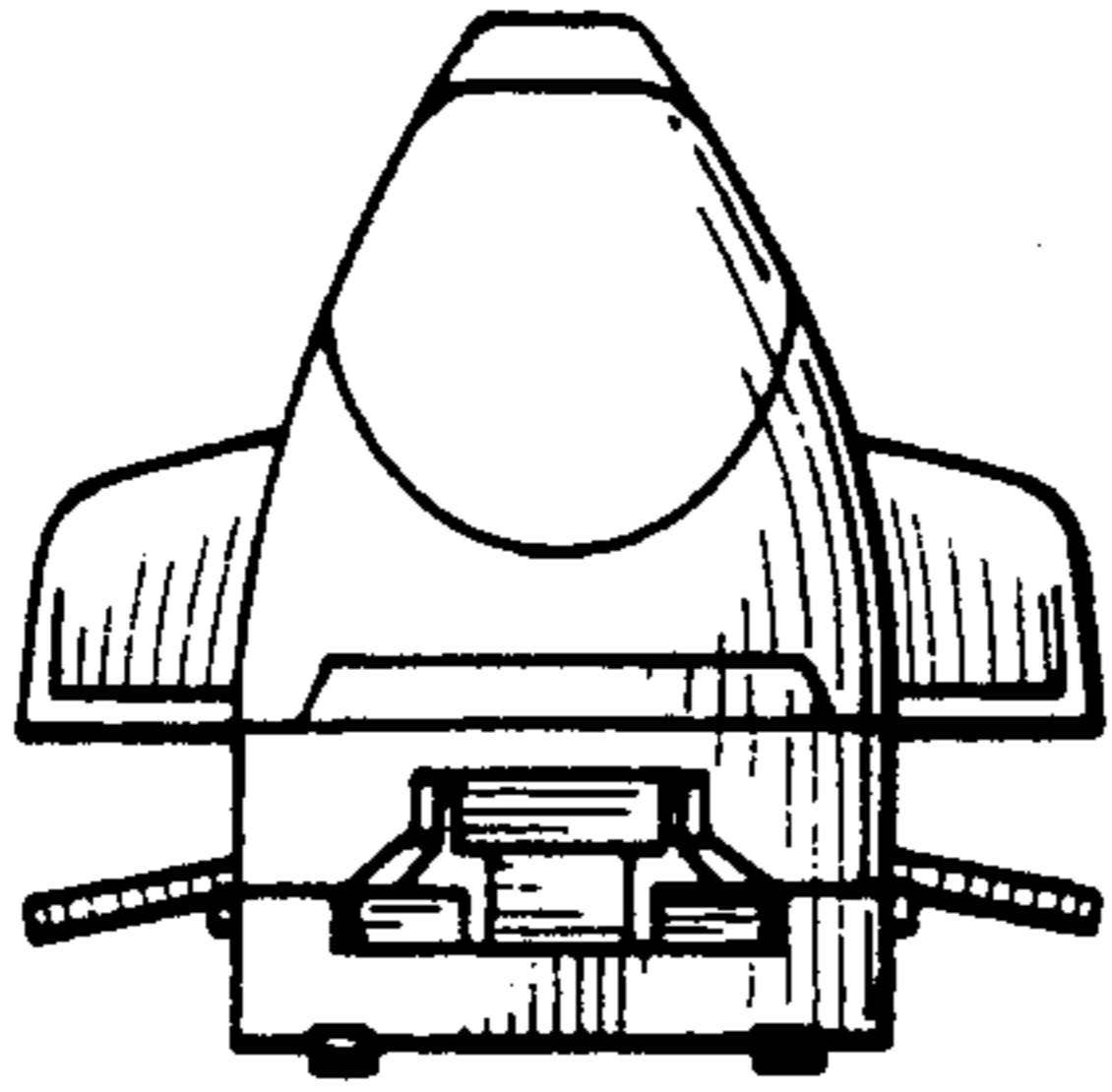

FIG. 2

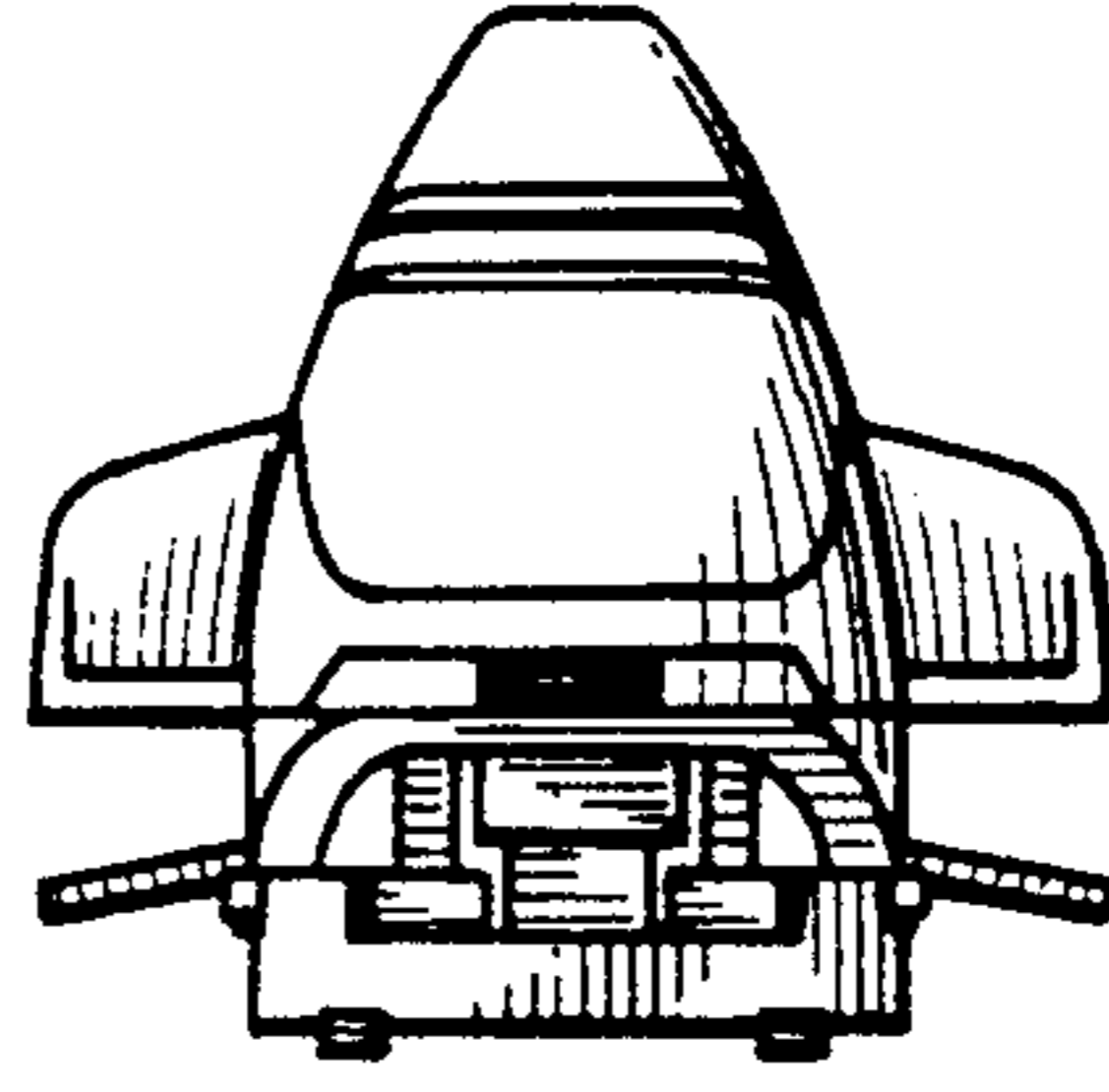

FIG. 3

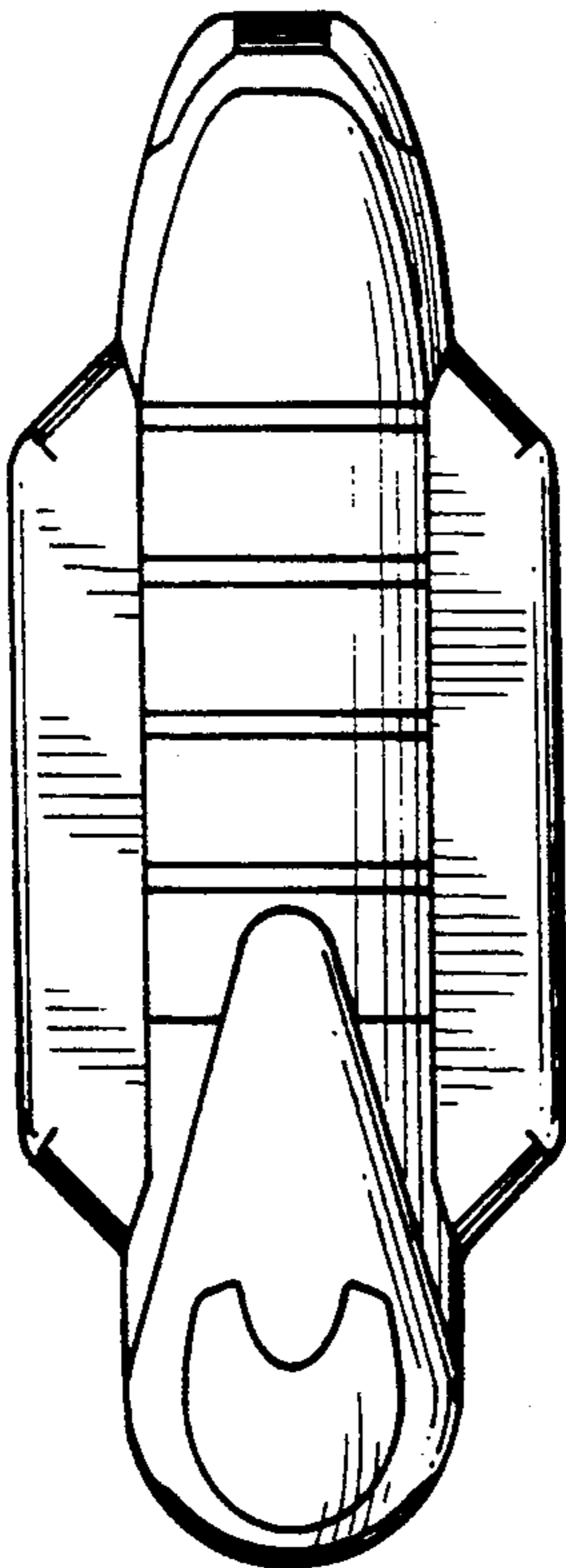

FIG. 4

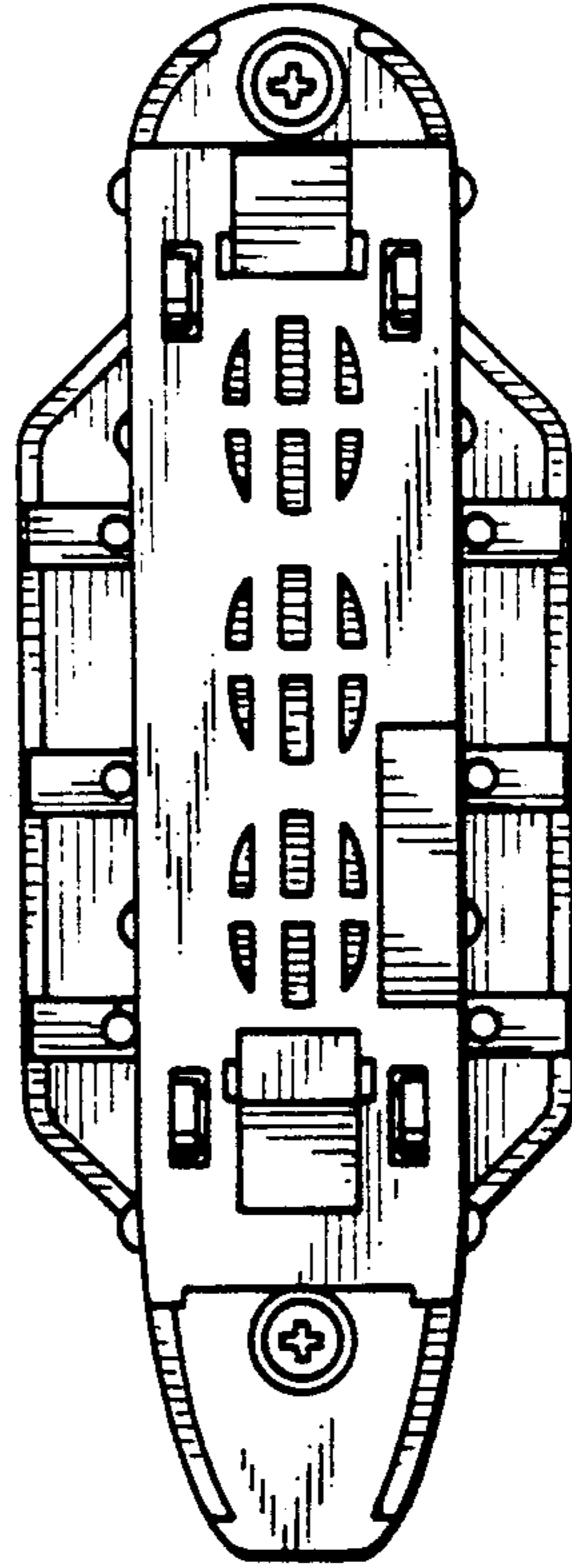

FIG. 5

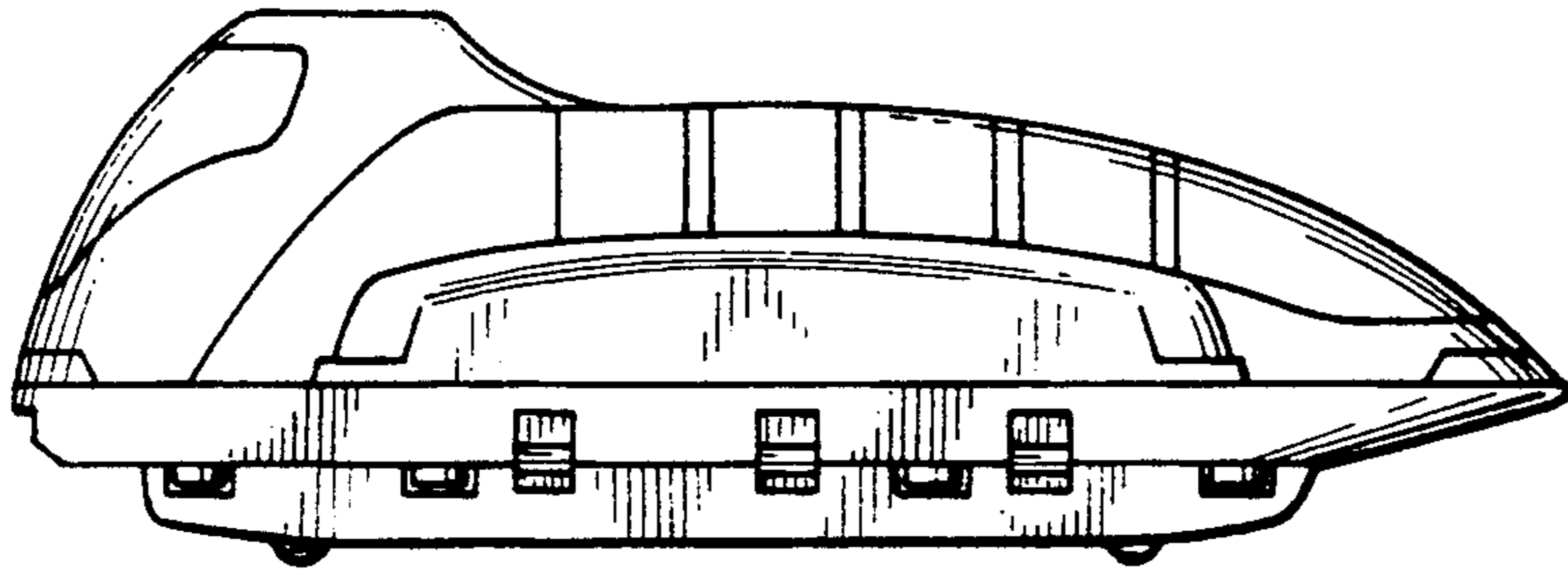

FIG. 6

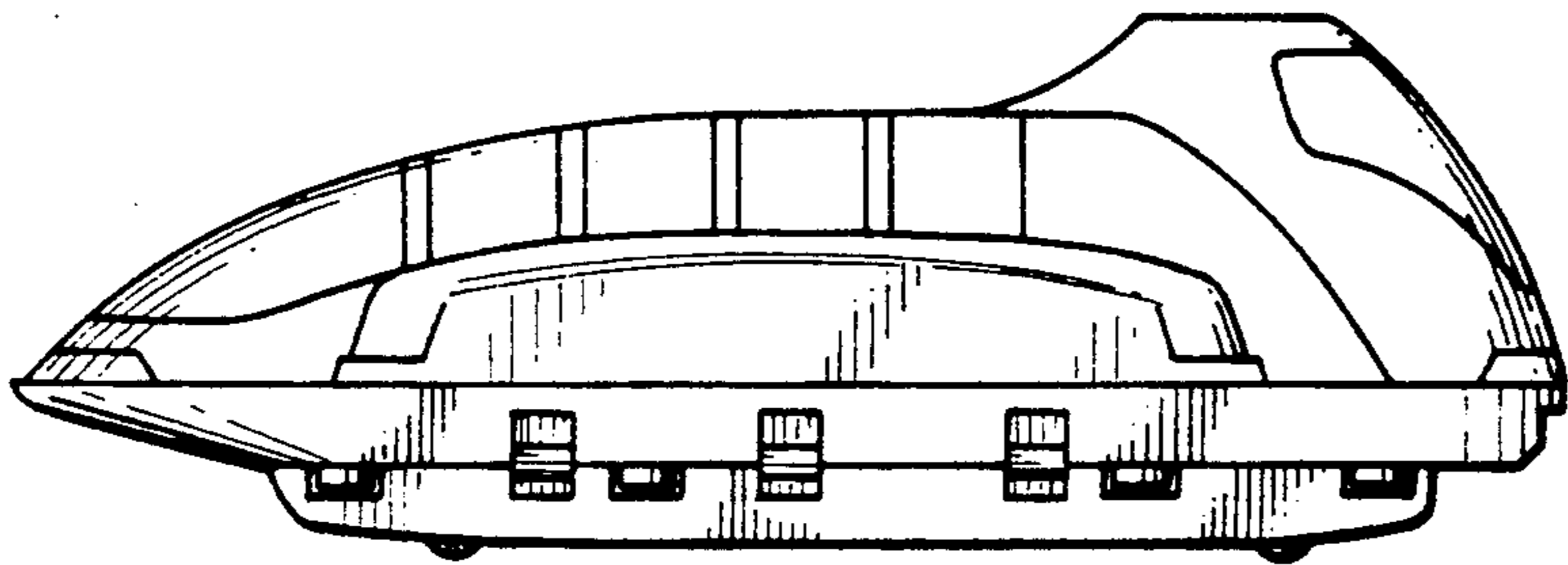

FIG. 7

