



US00D326629S

# United States Patent [19]

[11] Patent Number: **Des. 326,629**

Holler et al.

[45] Date of Patent: **\*\* Jun. 2, 1992**

[54] **AUTOMOBILE TRAILER**

[75] Inventors: **Frank A. Holler**, 1277 West 33rd Avenue, Vancouver, British Columbia, Canada, V6M1A4;  
**Bradley J. Martin**, 4890 Hudson SO, Vancouver, British Columbia, Canada, V6H3C2

3,977,720 8/1976 Schreiber ..... D12/102  
4,372,568 2/1983 Campbell ..... 280/63  
4,502,725 3/1985 Wiant ..... 296/181  
4,579,382 4/1986 Lake ..... 296/181

*Primary Examiner*—James M. Gandy  
*Assistant Examiner*—Melody Brown  
*Attorney, Agent, or Firm*—Wolf, Greenfield & Sacks

[73] Assignees: **Frank A. Holler; Bradley J. Martin**, both of Vancouver, Canada

### [57] CLAIM

[\*\*] Term: **14 Years**

The ornamental design for an automobile trailer, as shown and described.

[21] Appl. No.: **702,729**

### DESCRIPTION

[22] Filed: **May 20, 1991**

[52] U.S. Cl. .... **D12/102**

[58] Field of Search ..... D12/102, 104; 280/63, 280/656, 418.1, 491.1; 296/24.1, 168, 158, 181

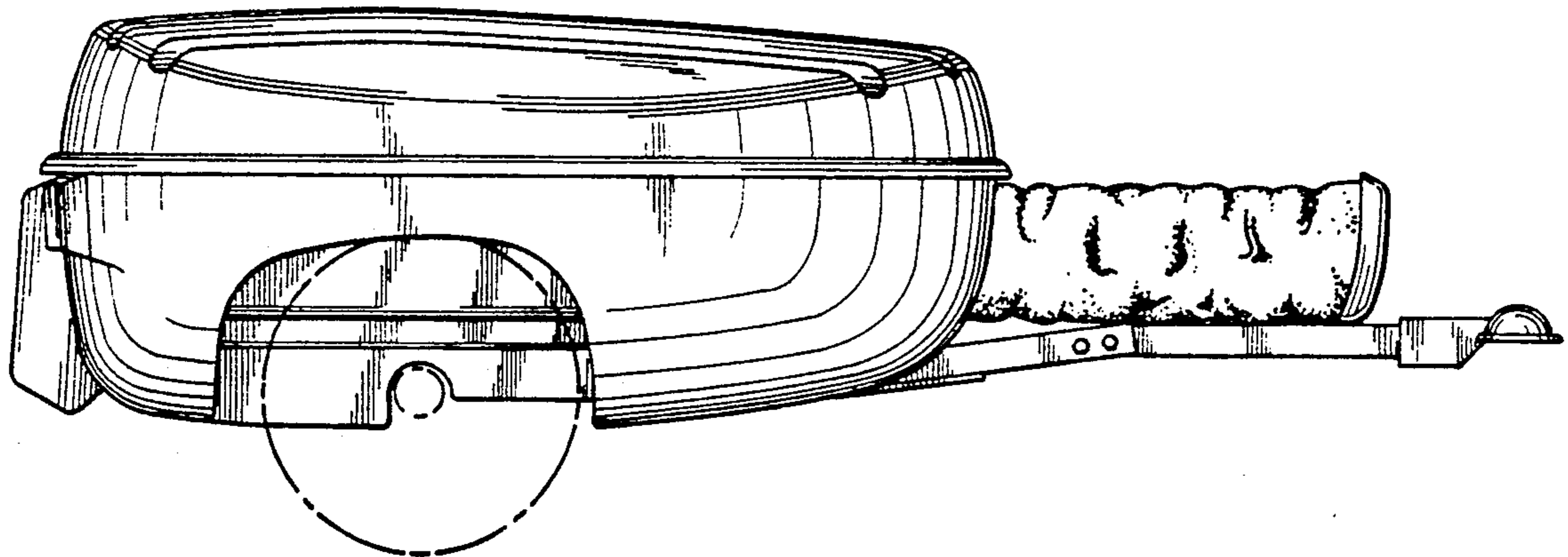
FIG. 1 is a right side elevation view of an automobile trailer showing my new design, it being understood that the broken lines are for illustrative purposes only and form no part of the claimed design, the left side being a mirror image thereof;

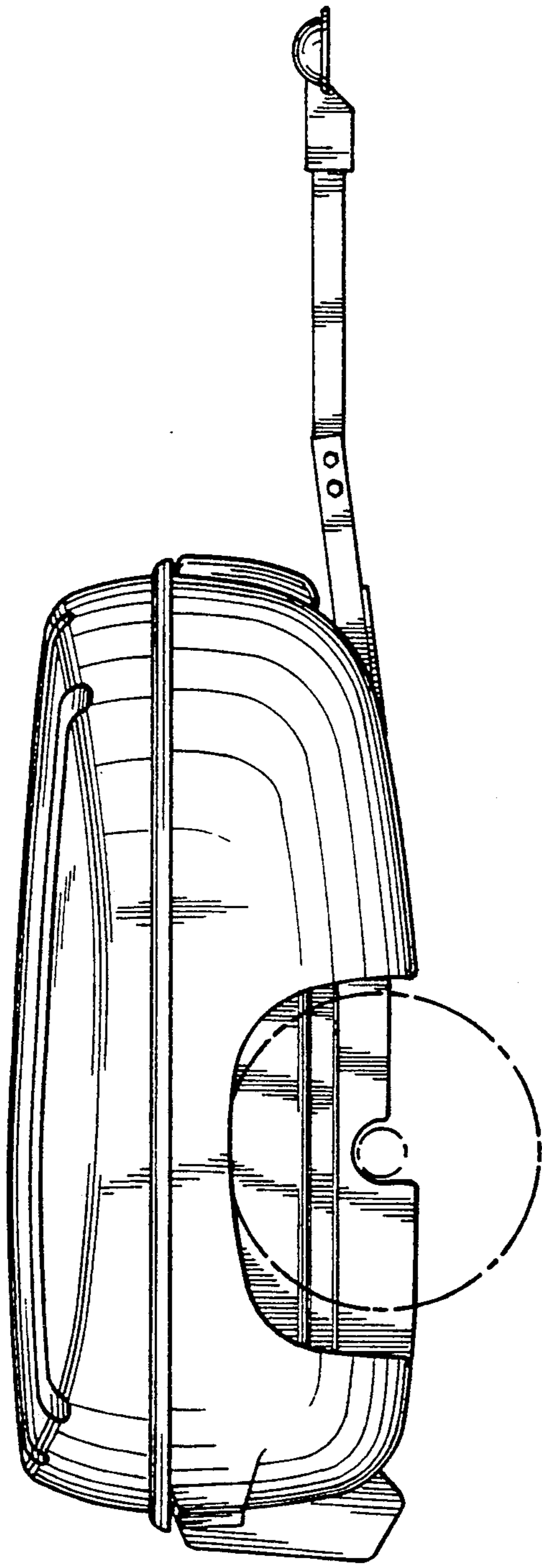
### [56] References Cited

#### U.S. PATENT DOCUMENTS

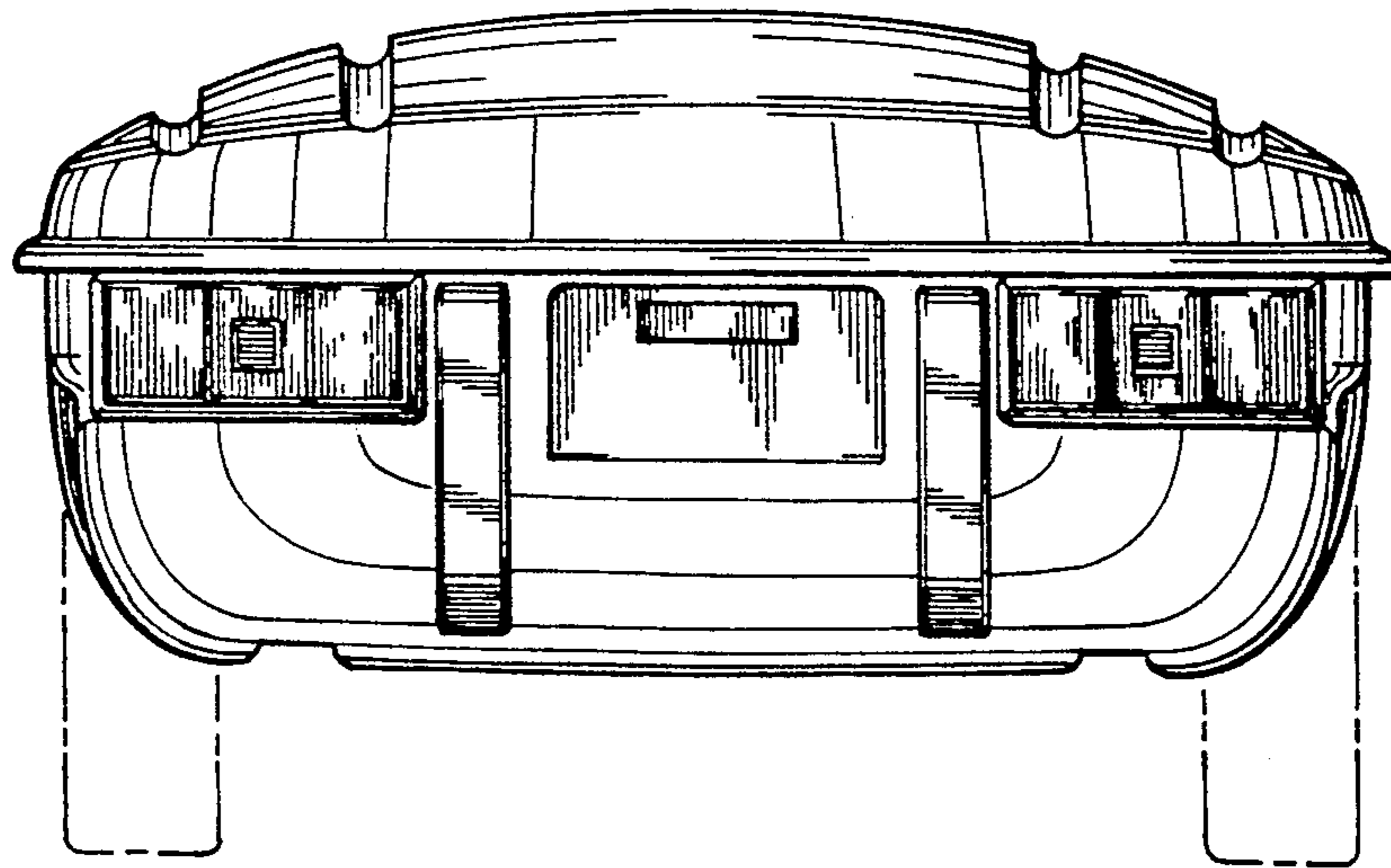
- D. 265,301 7/1982 Zander ..... D12/102
- D. 268,101 3/1983 Pope et al. .... D12/104
- D. 268,178 3/1983 Reid ..... D12/102
- D. 271,094 10/1983 Fisher ..... D12/102
- D. 272,996 3/1984 Trabue et al. .... D12/102

FIG. 2 is a rear elevation view thereof;  
FIG. 3 is a front elevation view thereof;  
FIG. 4 is a top plan view thereof;  
FIG. 5 is a bottom plan view thereof;  
FIG. 6 is a side elevation view thereof, with the front portion thereof in extended condition on a reduced scale, and,  
FIG. 7 is a top plan view of FIG. 6.

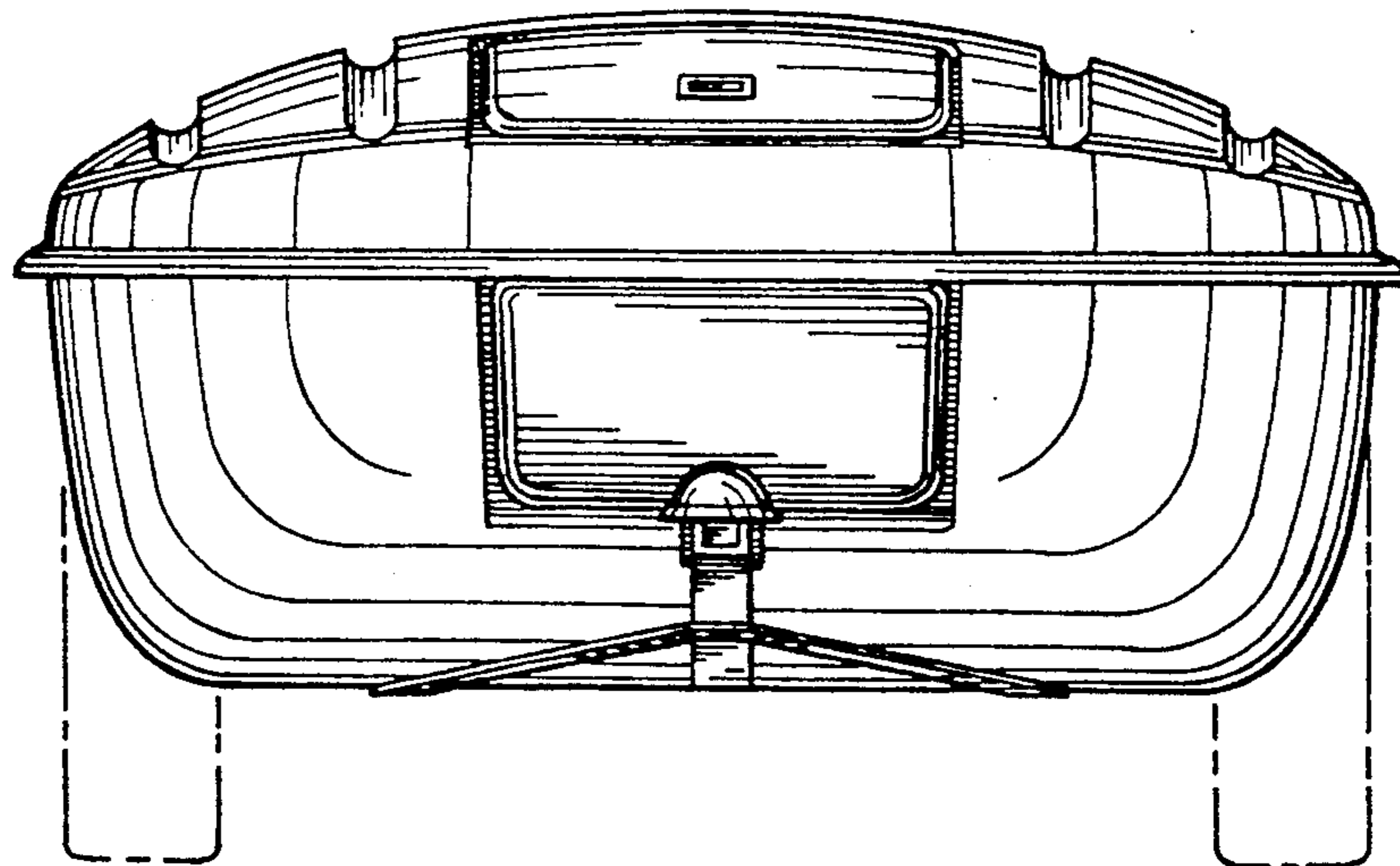




*FIG. 1*



*FIG. 2*



*FIG. 3*

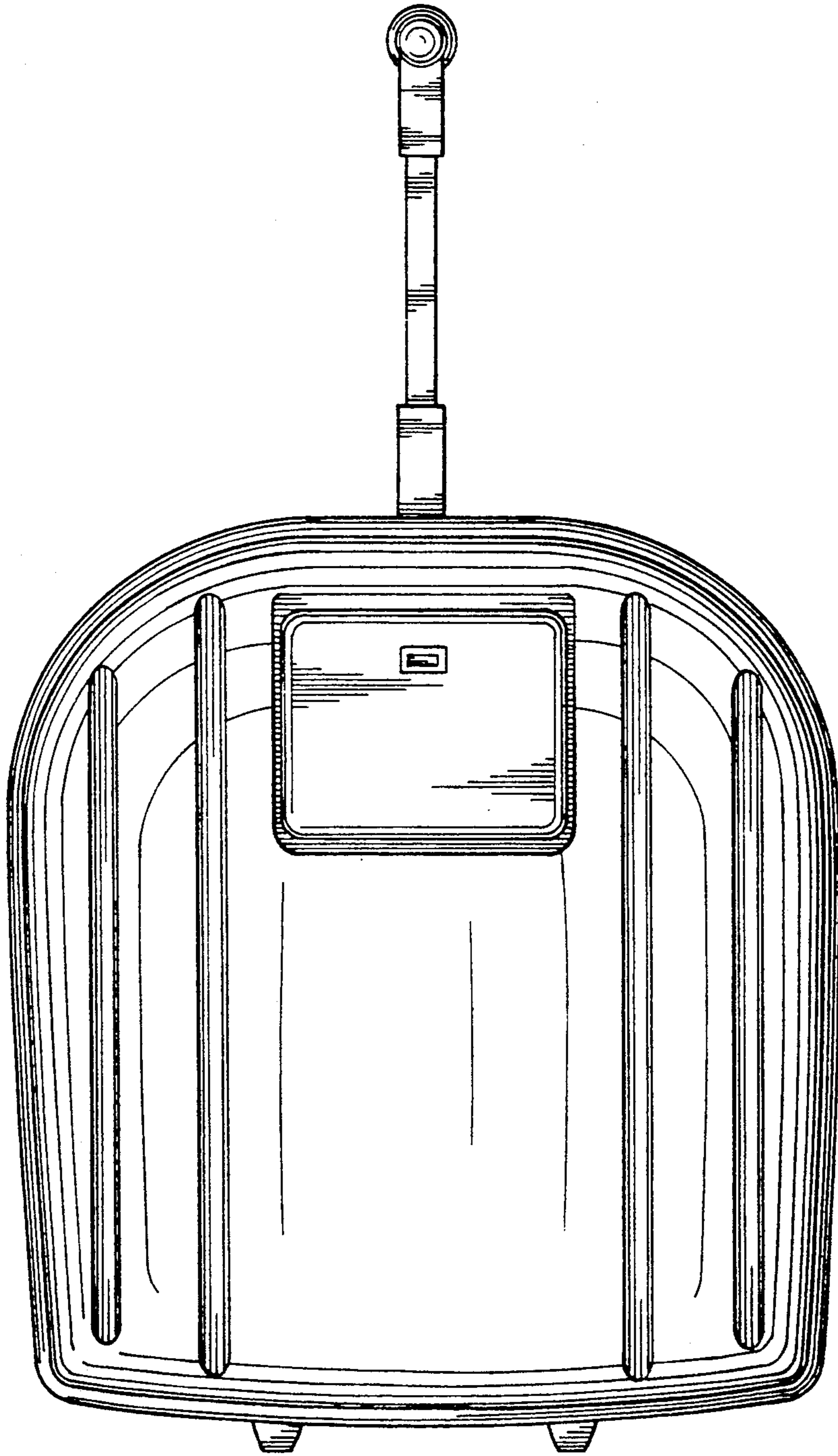


FIG. 4

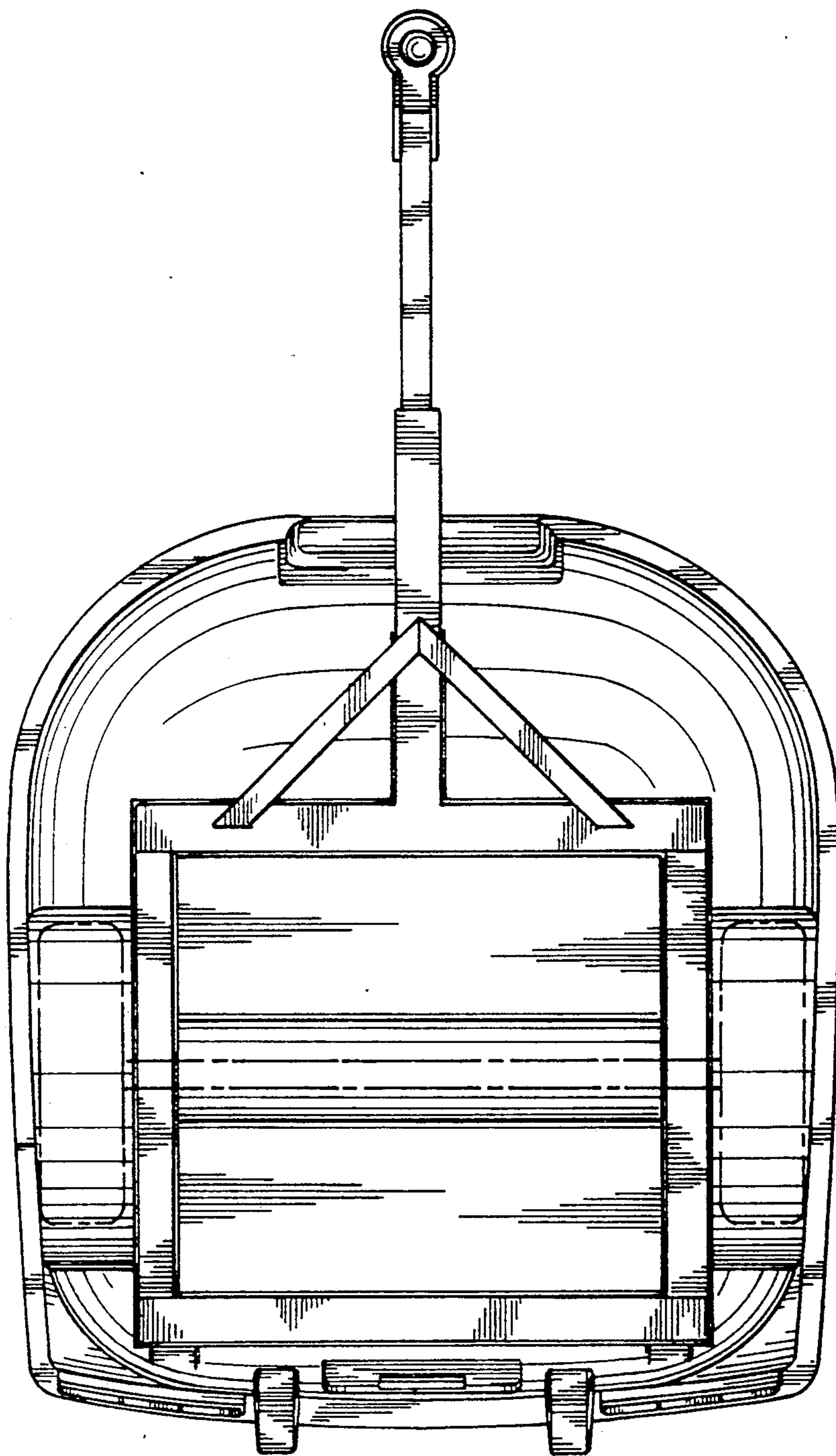


FIG. 5

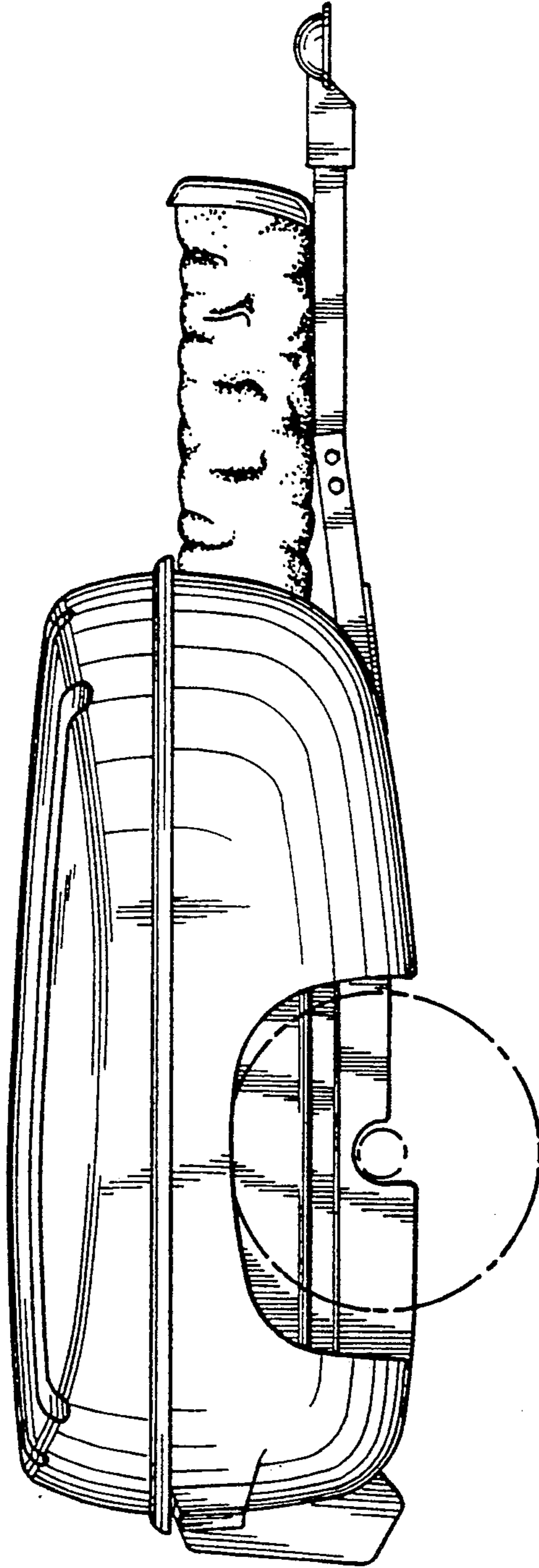


FIG. 6

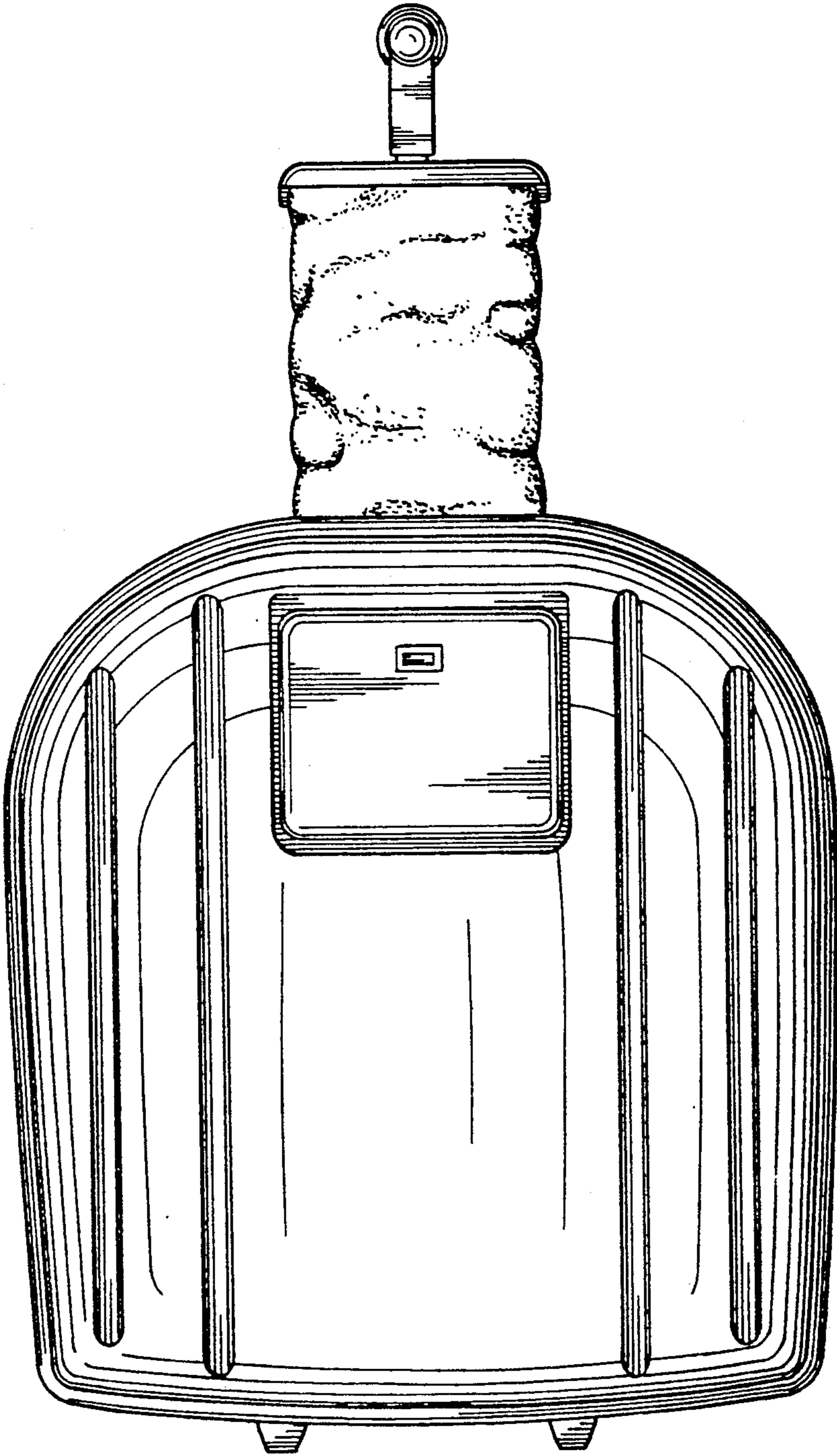


FIG. 7