



US00D326568S

United States Patent [19]

[11] Patent Number: **Des. 326,568**

Lanius et al.

[45] Date of Patent: **** Jun. 2, 1992**

[54] **VEHICLE SEAT**

[75] Inventors: **Charles A. Lanius, Prairie Du Sac;
John R. Huff, Reedsburg, both of
Wis.**

D. 283,857 5/1986 Livieratos D6/364
D. 291,508 8/1987 Herr D6/501 X
D. 297,995 10/1988 Stulik D6/501
D. 298,986 12/1988 Carter D6/356
4,707,027 11/1987 Horvath et al. D6/356 X

[73] Assignee: **Seats, Inc., Reedsburg, Wis.**

Primary Examiner—Donald P. Walsh
Assistant Examiner—Gary D. Watson
Attorney, Agent, or Firm—Michael, Best & Friedrich

[**] Term: **14 Years**

[21] Appl. No.: **318,357**

[57] **CLAIM**

[22] Filed: **Mar. 3, 1989**

The ornamental design for a vehicle seat, as shown and described.

[52] U.S. Cl. **D6/356**

[58] Field of Search D6/334, 356, 380, 500,
D6/368, 501

DESCRIPTION

[56] **References Cited**

U.S. PATENT DOCUMENTS

- D. 180,392 6/1957 Del Guidice D6/356
- D. 183,233 7/1958 Ahrens D6/368 X
- D. 249,102 8/1978 Pelly D6/334 X
- D. 250,442 12/1978 Pesiri D6/368
- D. 264,774 6/1982 McGirk et al. D6/356
- D. 273,540 4/1984 Wagner et al. D6/356
- D. 277,239 1/1985 White D6/356
- D. 280,470 9/1985 Higgins D6/356
- D. 280,471 9/1985 Higgins D6/356
- D. 281,472 11/1985 Soederberg D6/356
- D. 282,609 2/1986 Stulik D6/356

FIG. 1 is a perspective view of a vehicle seat showing our new design;
 FIG. 2 is front elevational view thereof;
 FIG. 3 is a right side elevational view thereof, the left side elevational view being a mirror image of the right side elevational view;
 FIG. 4 is a rear elevational view thereof;
 FIG. 5 is a perspective view of a second embodiment of a vehicle seat showing our new design;
 FIG. 6 is a front elevational view thereof;
 FIG. 7 is a right side elevational view thereof, the left side elevational view being a mirror image of the right side elevational view; and,
 FIG. 8 is a rear elevational view thereof.

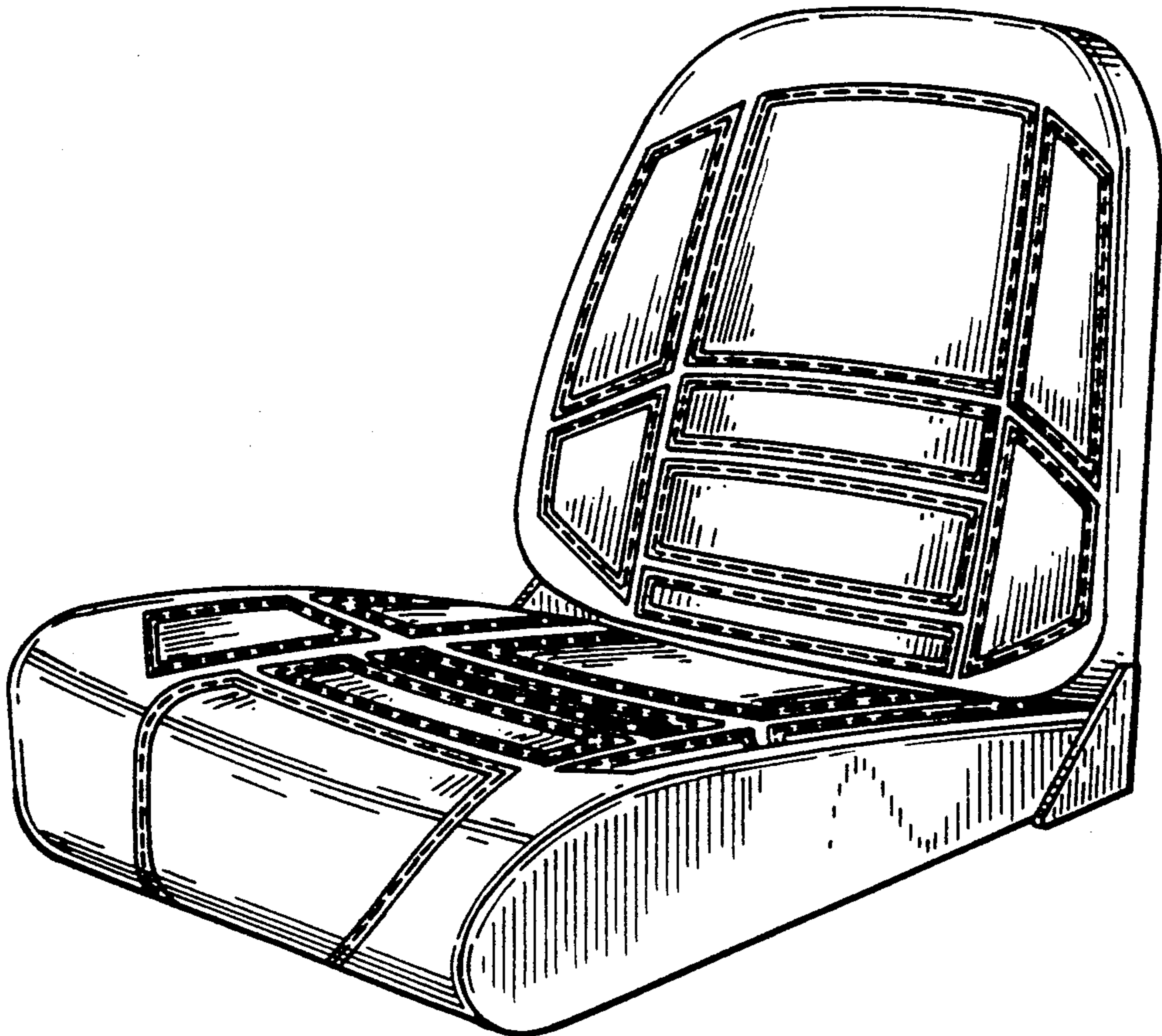

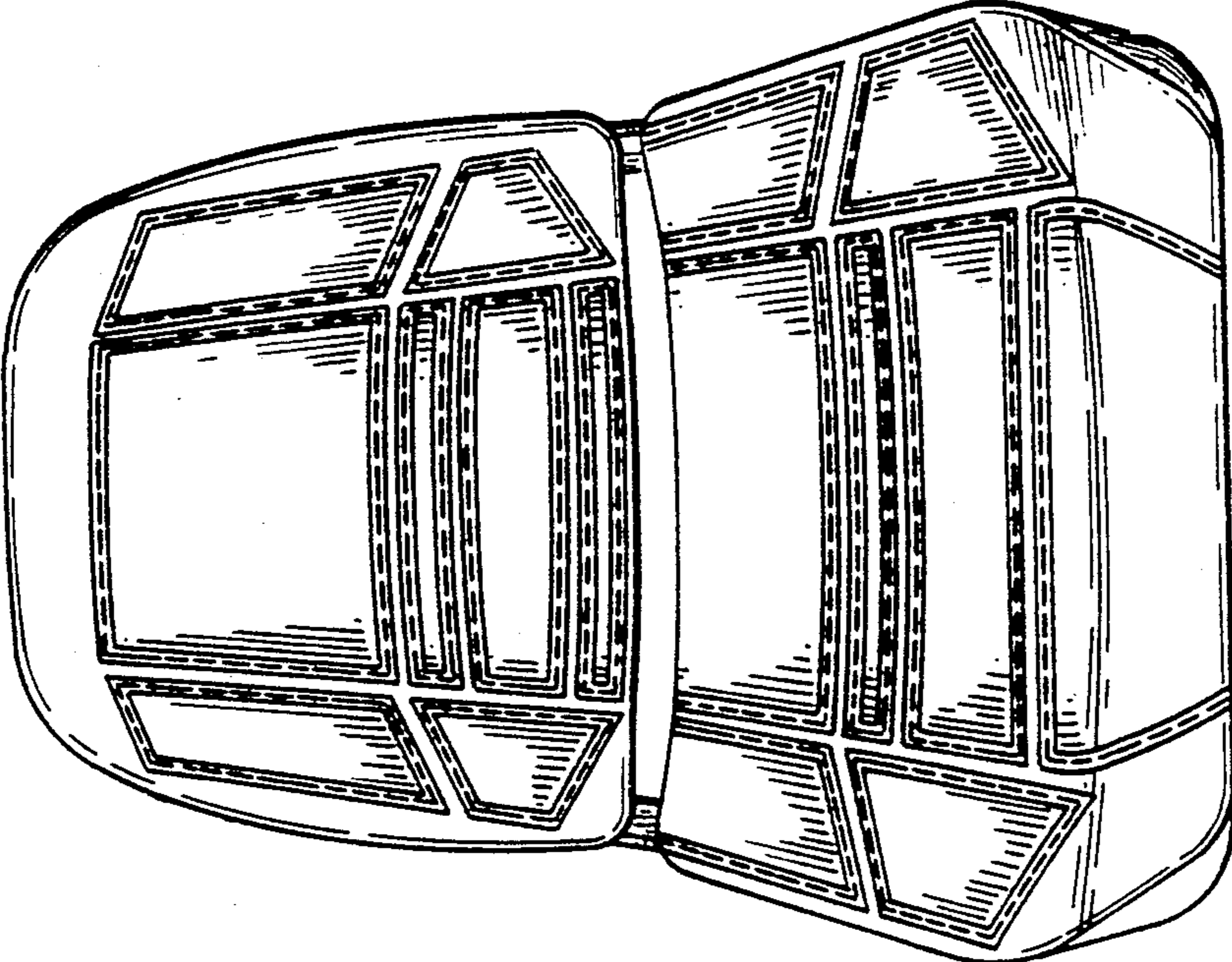

Fig. 2

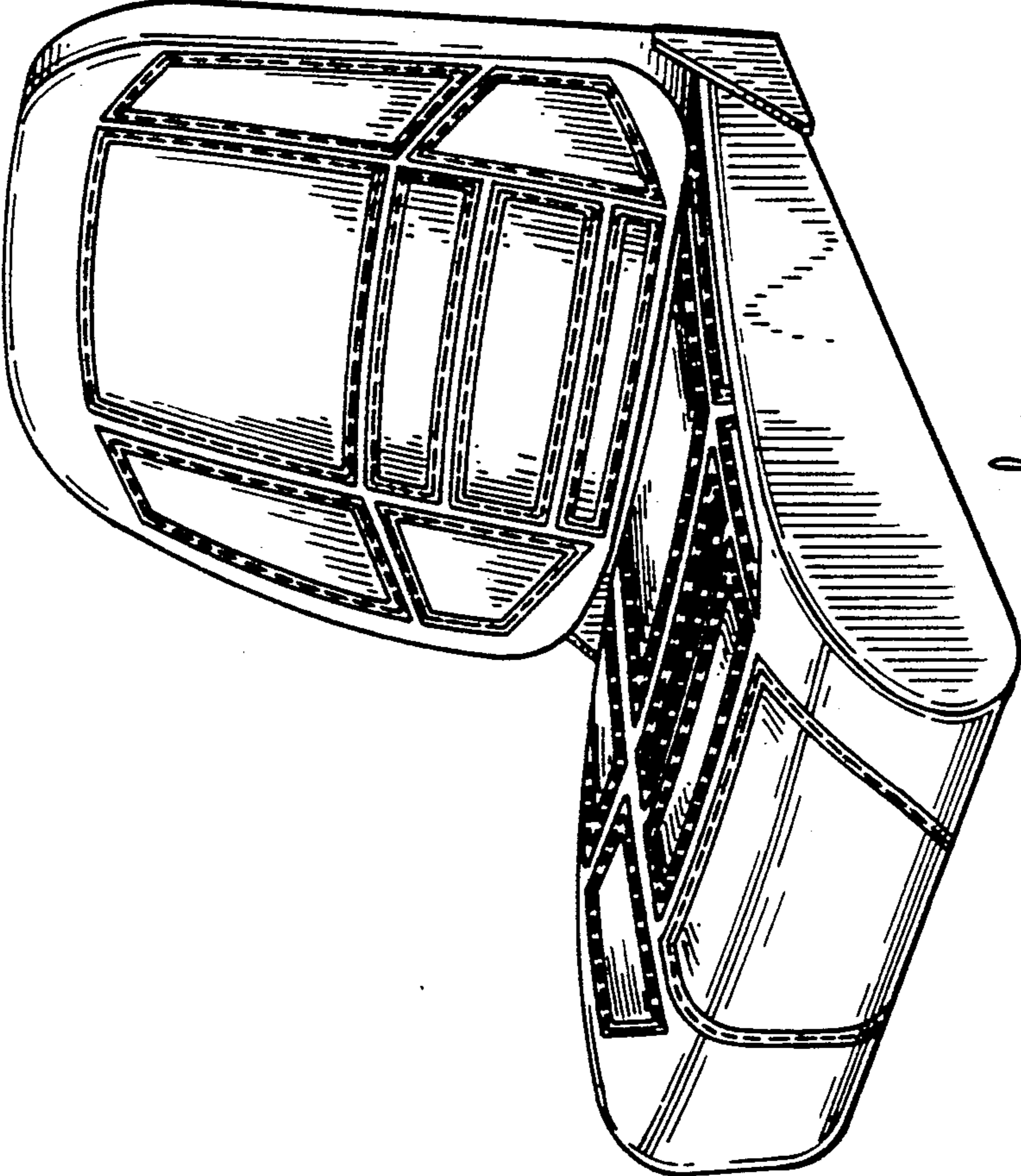

Fig. 1

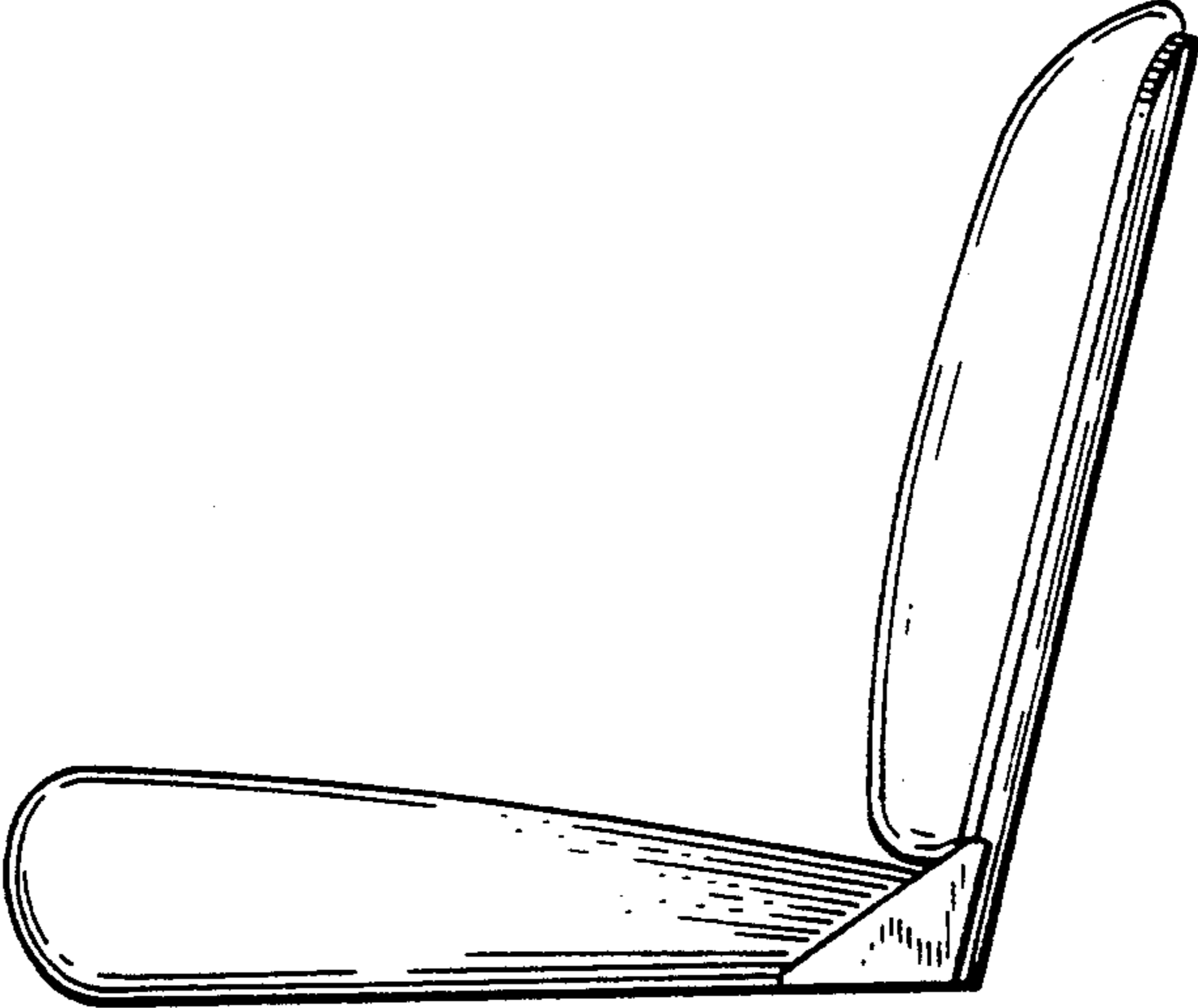

fig. 3

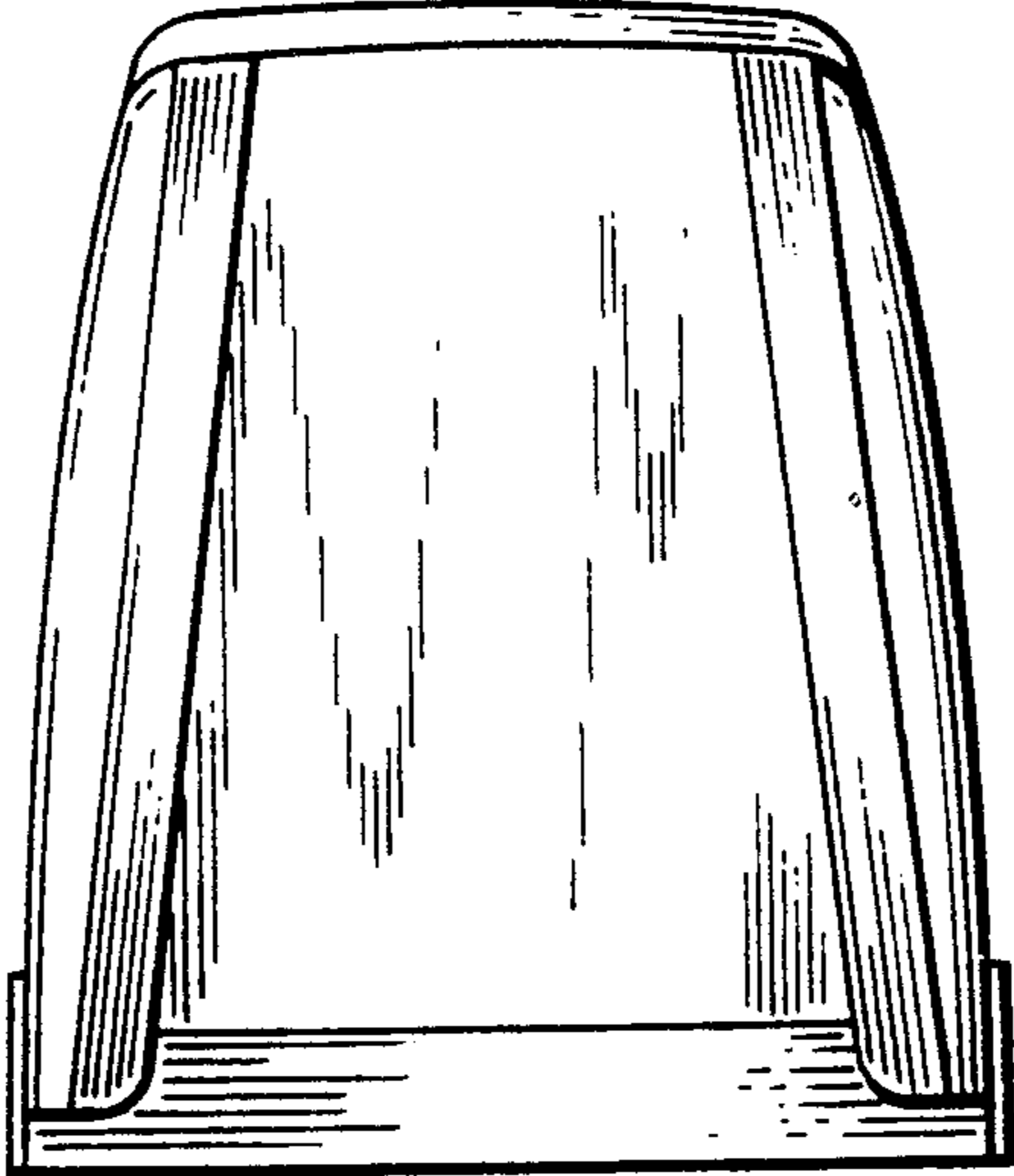

fig. 4

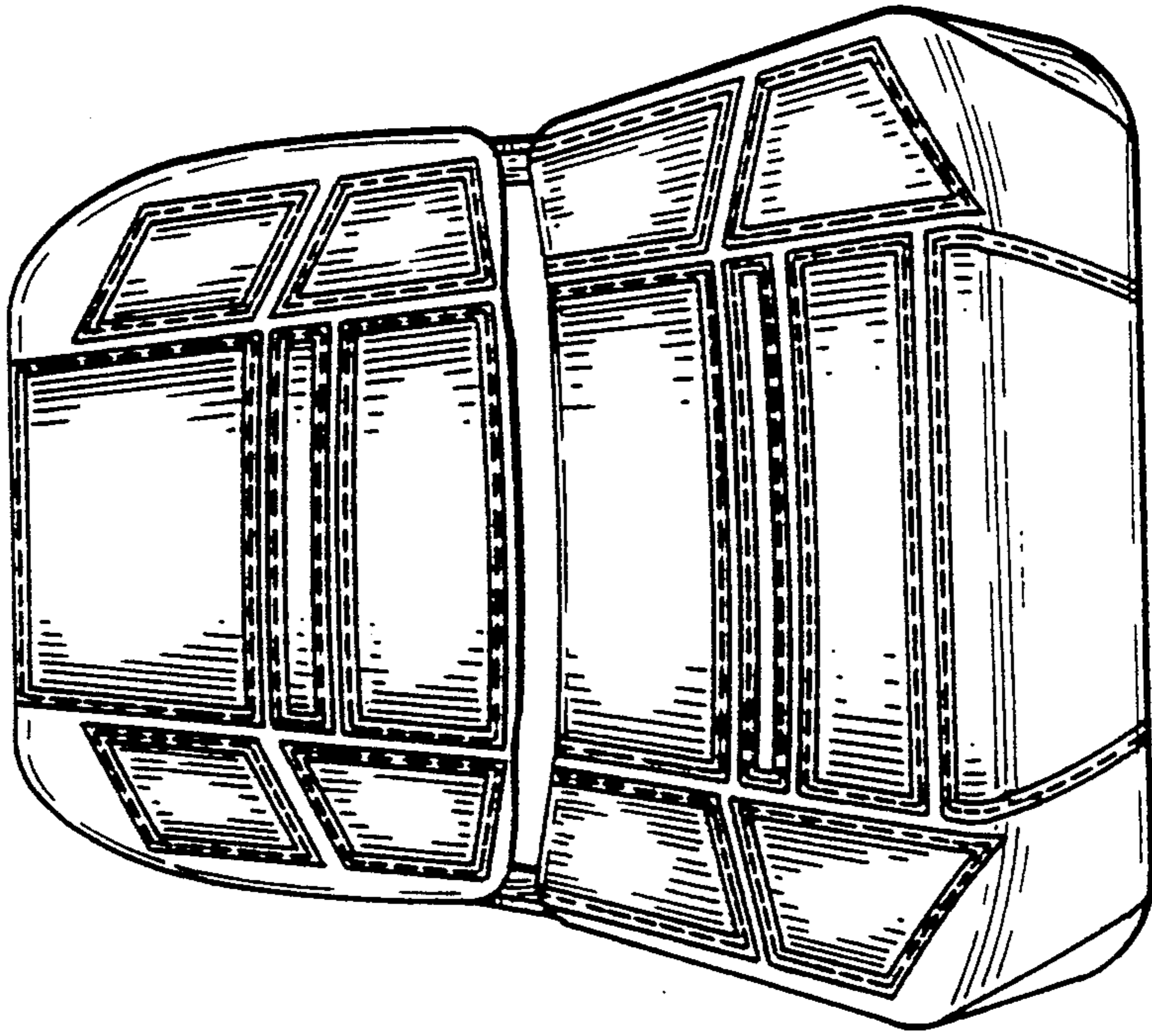

Fig. 6

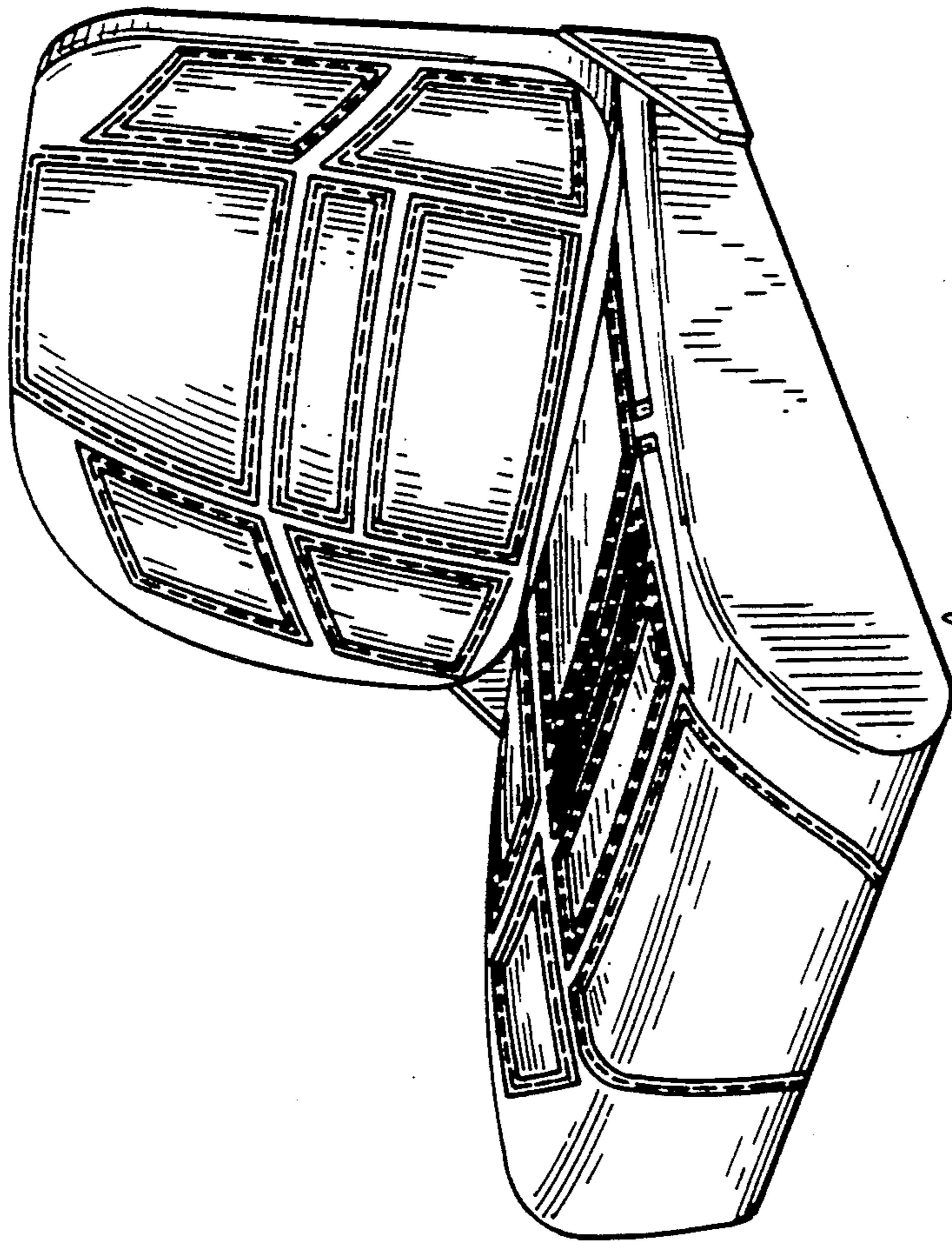

Fig. 5

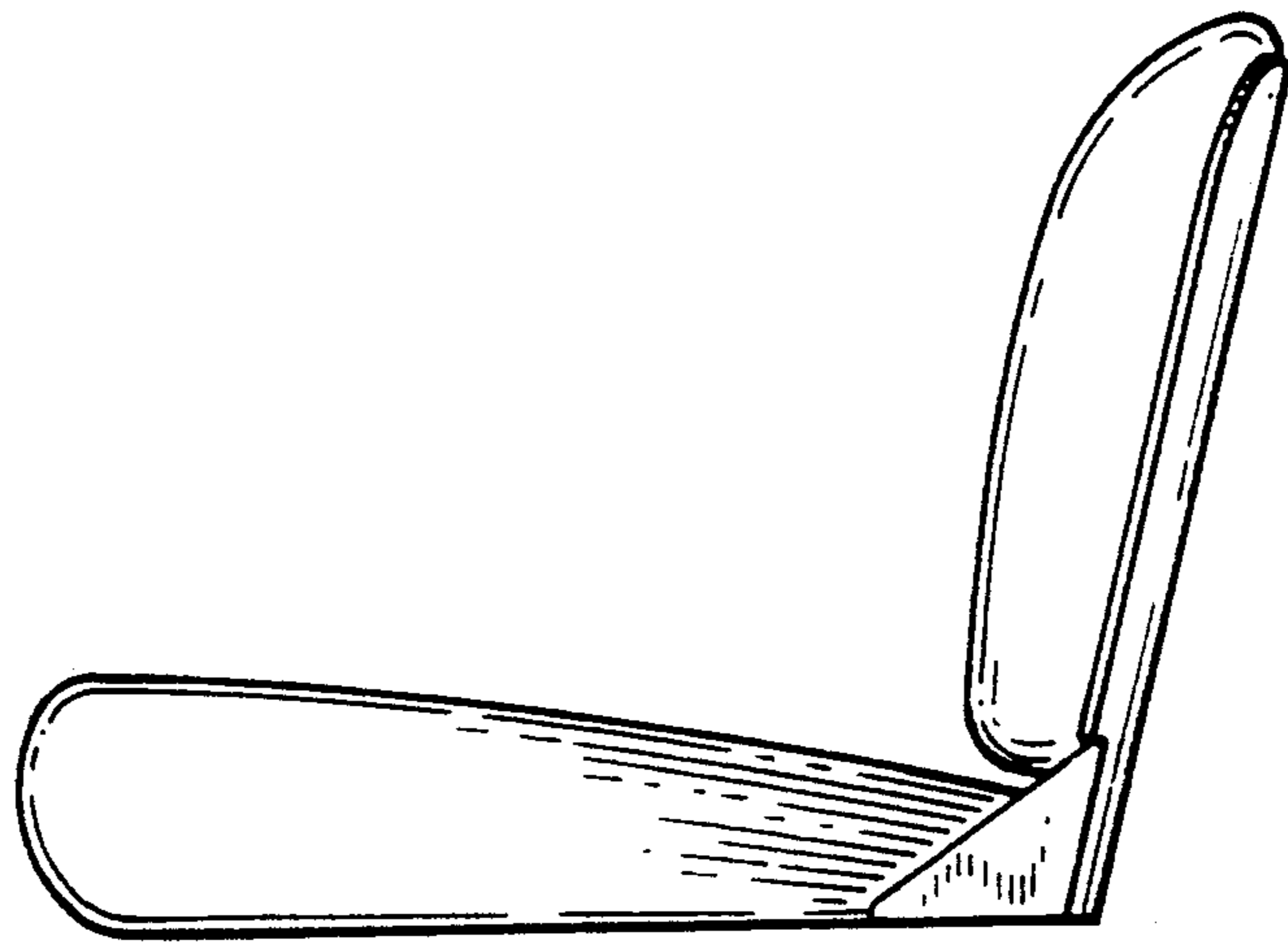

fig. 7

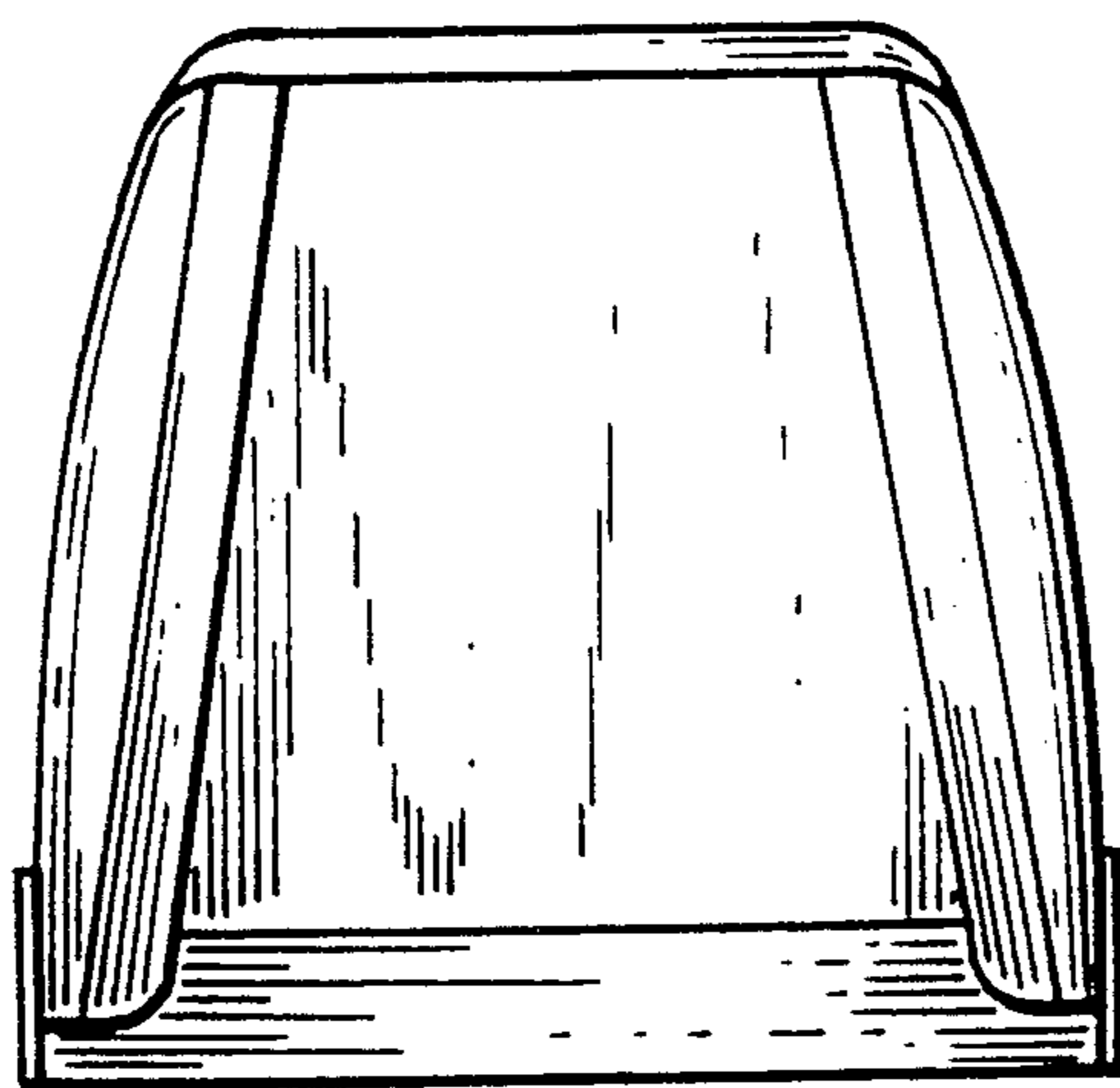

fig. 8