



US00D326561S

# United States Patent [19]

[11] Patent Number: **Des. 326,561**

Imbert

[45] Date of Patent: **\*\* Jun. 2, 1992**

[54] **HANDBAG**

D. 202,248 9/1965 Schlessinger ..... D3/504  
4,004,325 1/1977 Hubachek ..... D3/524

[75] Inventor: **Jocelyne Imbert, Marseille, France**

[73] Assignee: **Louis Vuitton Malletier, Paris, France**

*Primary Examiner*—Wallace R. Burke  
*Assistant Examiner*—P. Schmidt  
*Attorney, Agent, or Firm*—Merchant & Gould Smith, Edell, Welter & Schmidt

[\*\*] Term: **14 Years**

[57] **CLAIM**

[21] Appl. No.: **329,095**

The ornamental design for a handbag, as shown and described.

[22] Filed: **Mar. 27, 1989**

[30] **Foreign Application Priority Data**

**DESCRIPTION**

Sep. 26, 1988 [XH] Hague ..... DMA/000838

FIG. 1 is a front perspective view of a handbag showing my new design;

[52] U.S. Cl. .... **D3/42**

FIG. 2 is a front perspective view thereof, with the top flap shown in a fully opened position;

[58] Field of Search ..... D3/30.1, 106, 42, 43, D3/44, 53, 74, 50, 76, 52, 78, 79, 99; 199/107, 109, 100; 383/43, 44; 150/100, 118, 131, 132, 127, 107, 108, 110

FIG. 3 is a rear elevational view thereof;

[56] **References Cited**

**U.S. PATENT DOCUMENTS**

D. 160,475 10/1950 Cohan ..... D3/524  
D. 171,844 3/1954 Satnick ..... D3/504  
D. 176,410 12/1955 Hardy ..... D3/53

FIG. 4 is a side elevational view thereof, the undisclosed side being a mirror image;

FIG. 5 is a top plan view thereof; and,

FIG. 6 is a bottom plan view thereof.

The broken line shown in all views represents conventional stitching.

FIGS. 3-5 show the extension belt forming part of the handle omitted for ease of illustration only.

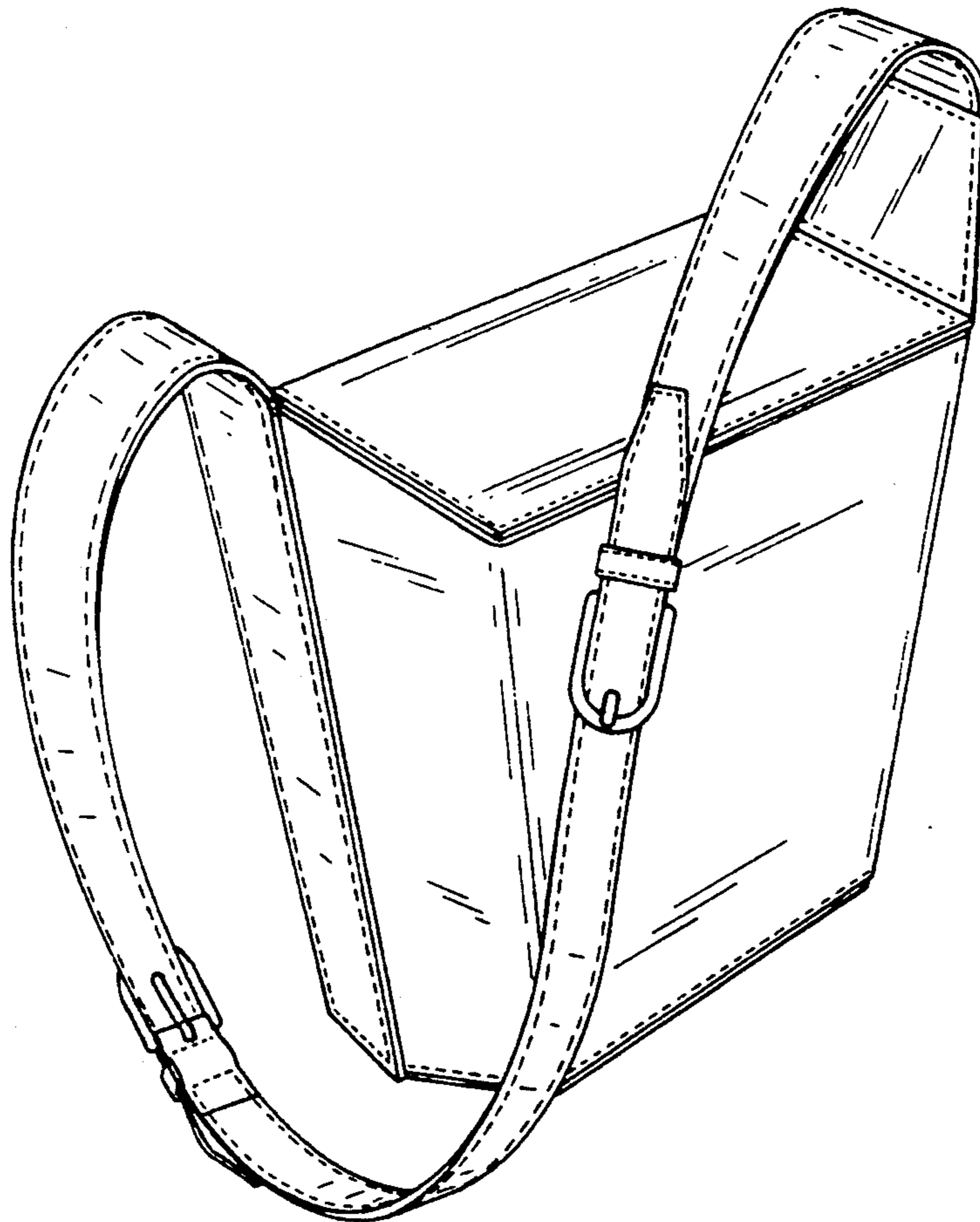

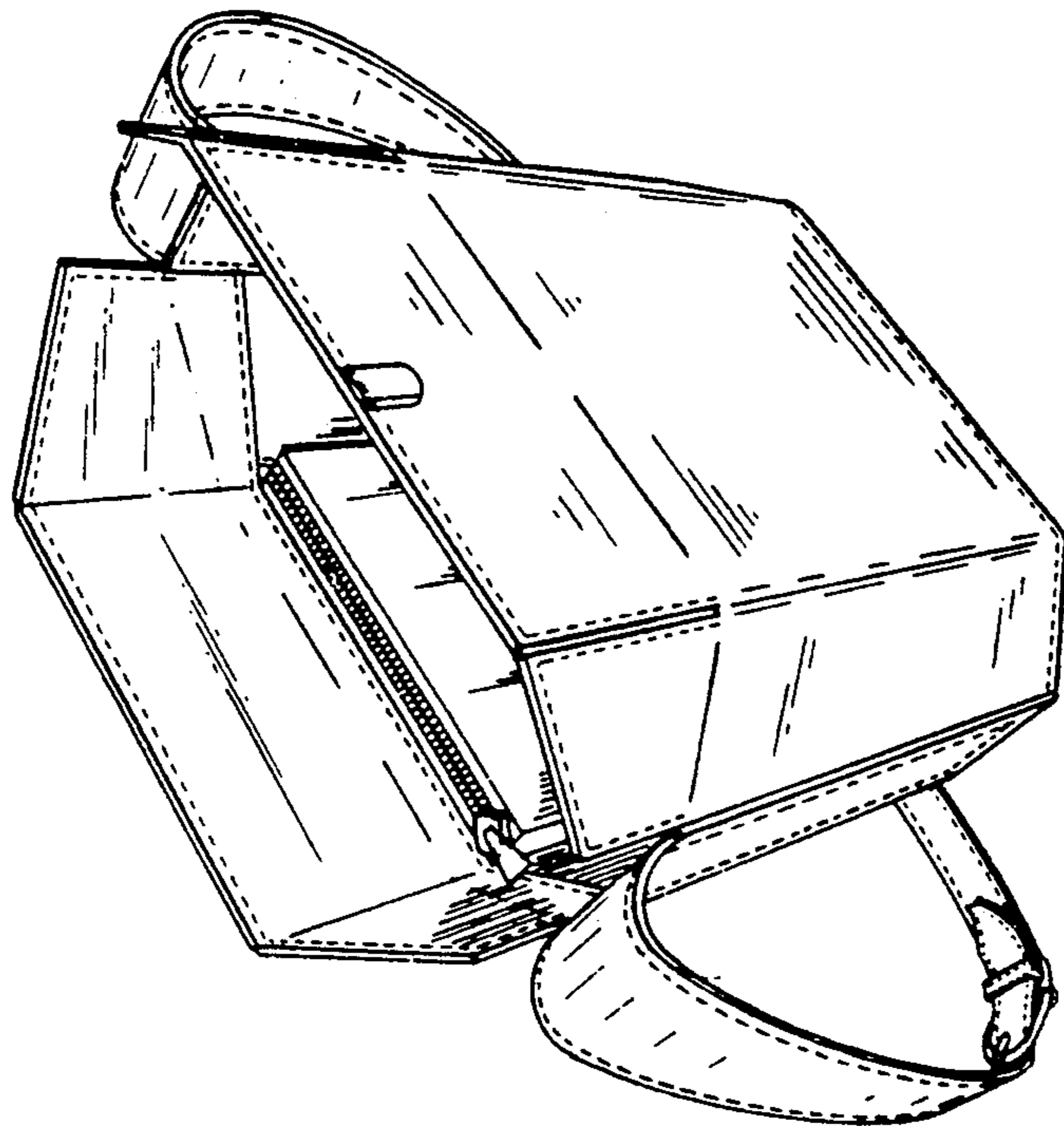

FIG. 2

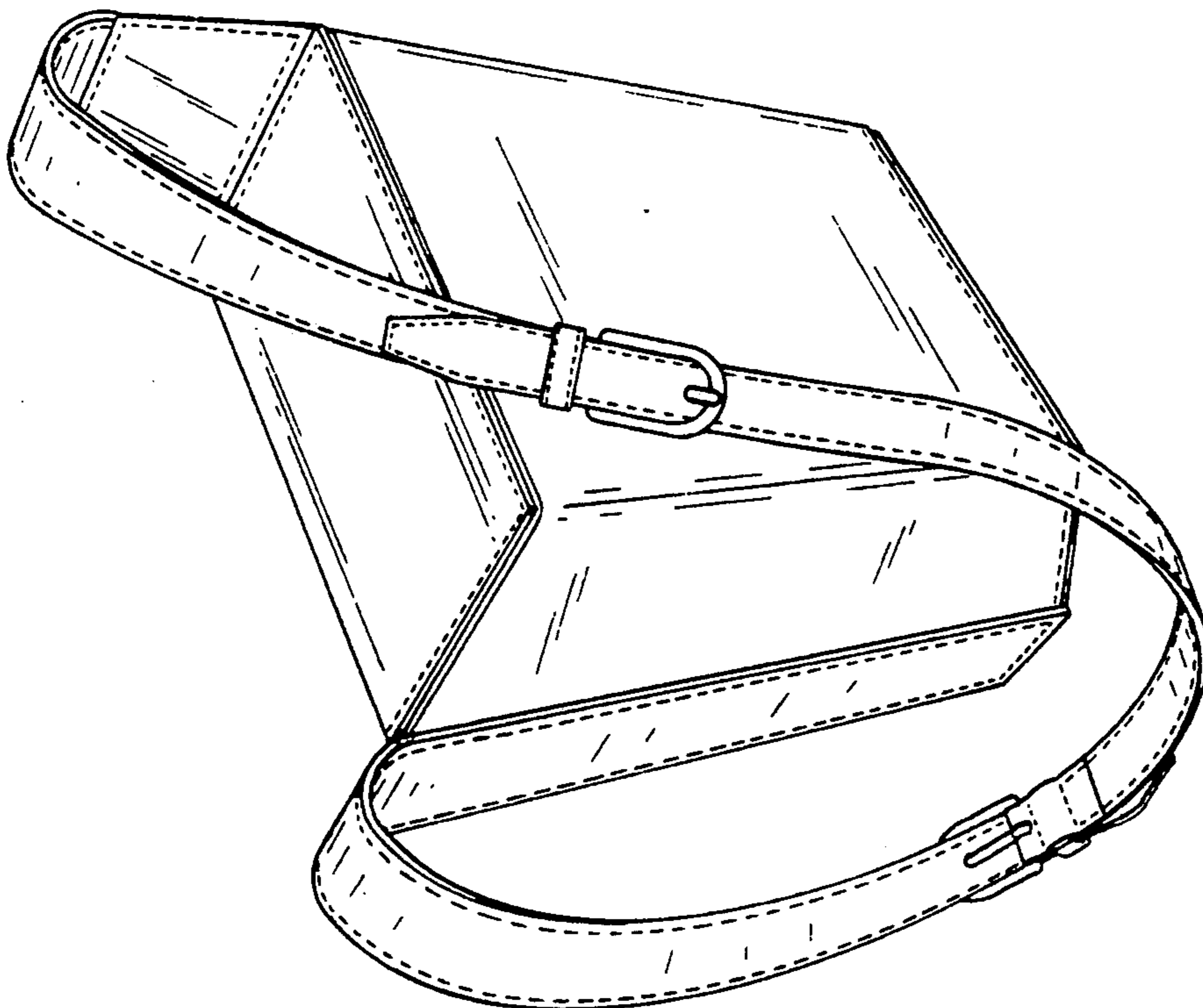

FIG. 1

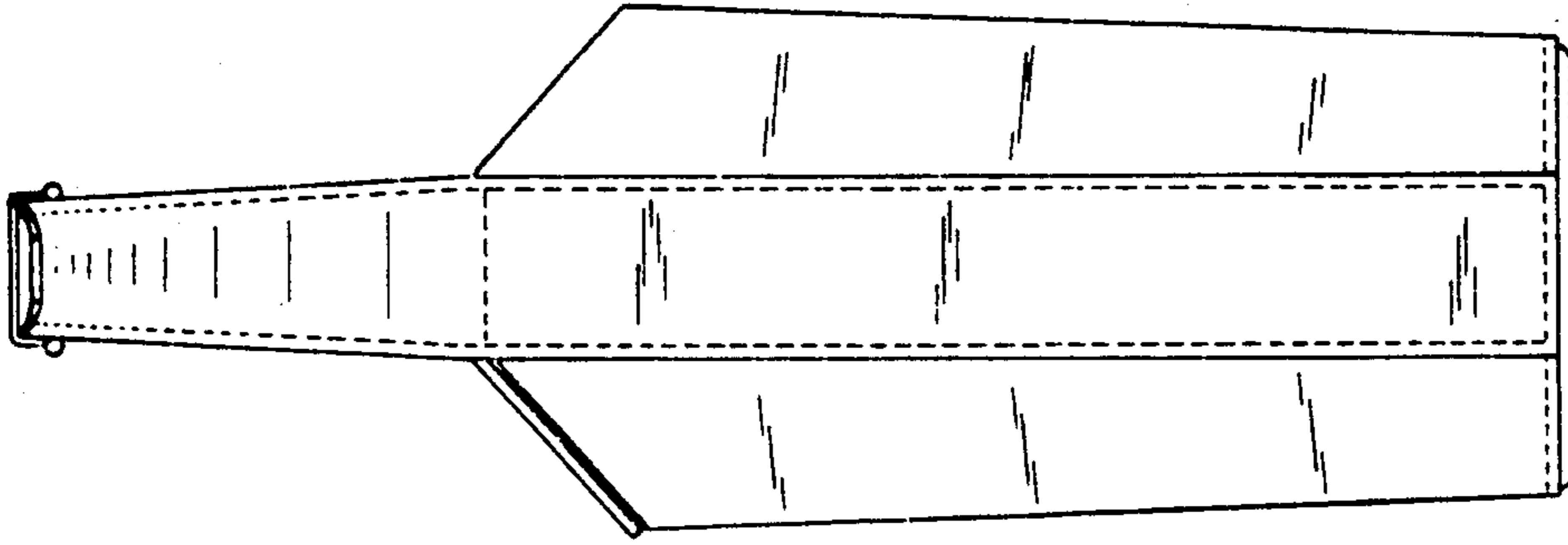

FIG. 4

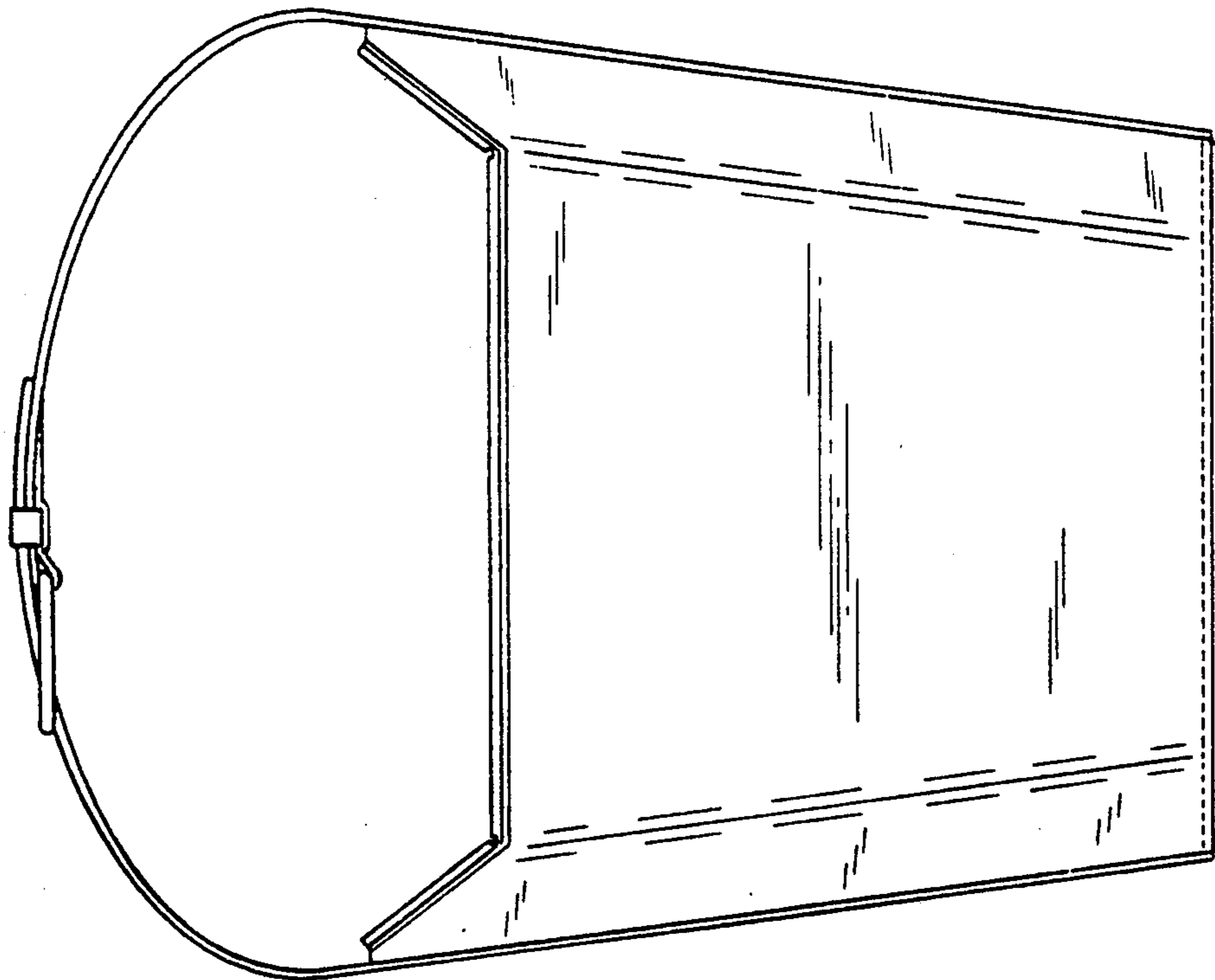

FIG. 3

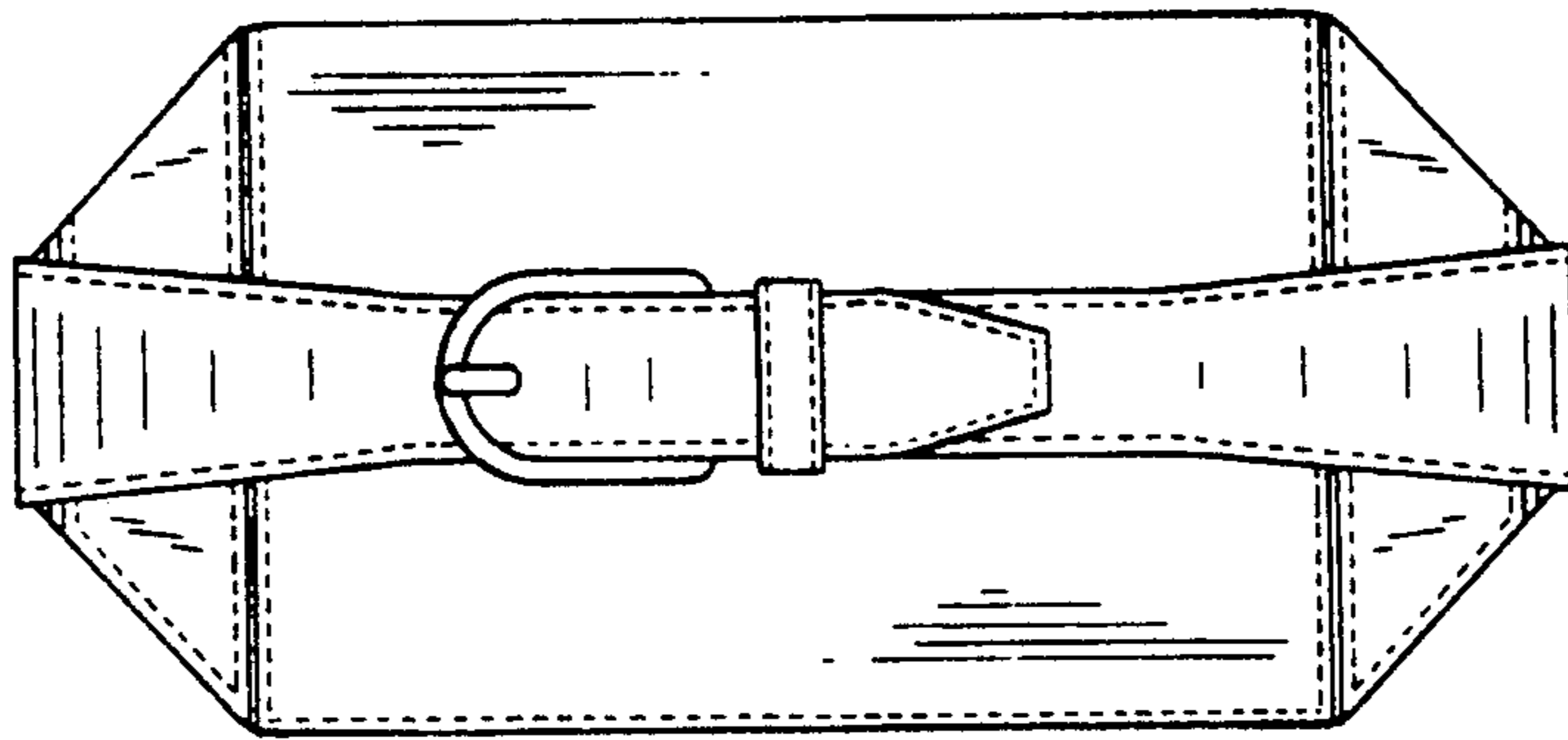

FIG. 5

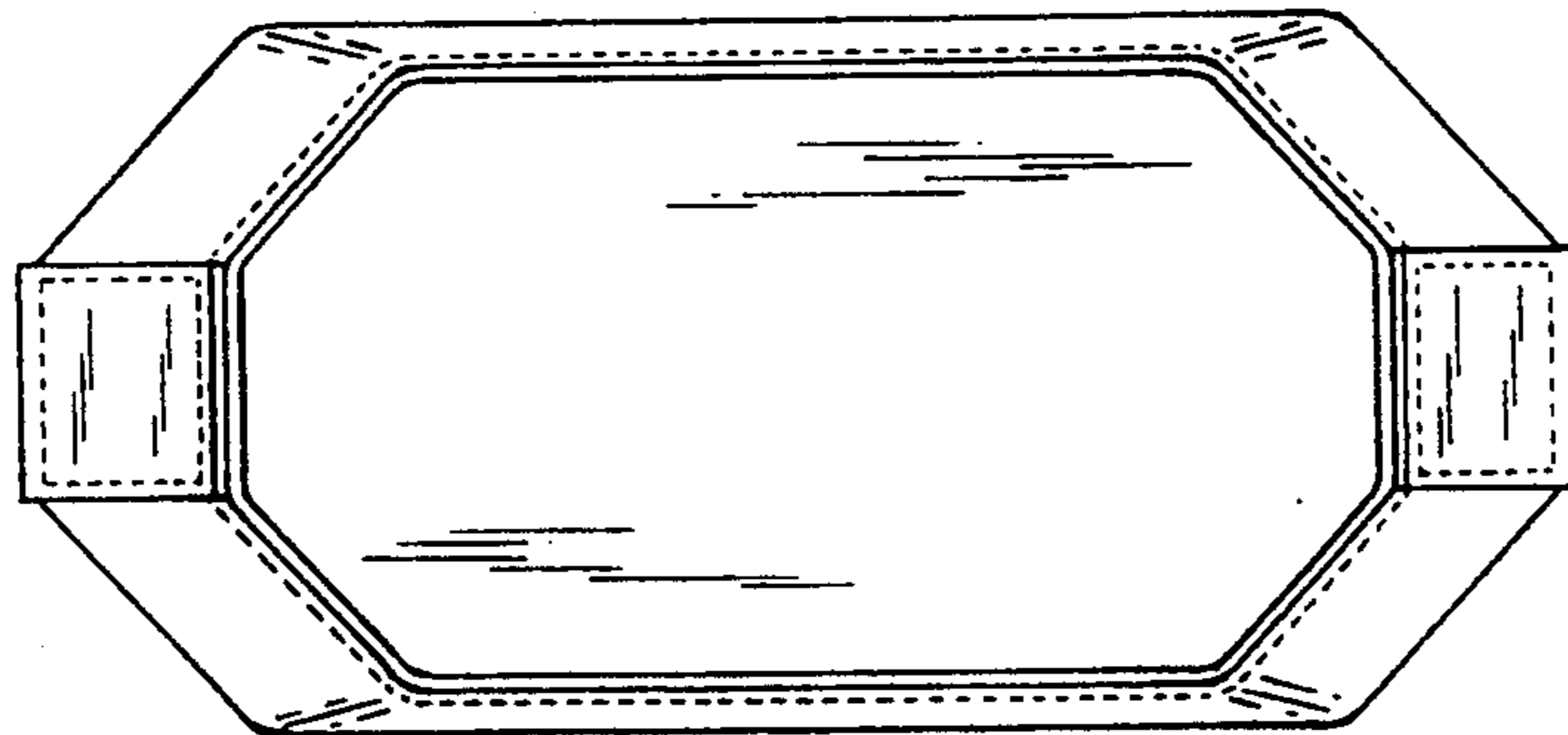

FIG. 6