



US00D326450S

United States Patent [19]

[11] Patent Number: Des. 326,450

Watanabe

[45] Date of Patent: ** May 26, 1992

[54] AUTOMOTIVE TELEPHONE CONTROL UNIT

[75] Inventor: Katsuhito Watanabe, Tokyo, Japan

[73] Assignee: Oki Electric Industry Co., Ltd., Tokyo, Japan

[**] Term: 14 Years

[21] Appl. No.: 638,423

[22] Filed: Jan. 7, 1991

[30] Foreign Application Priority Data

Oct. 5, 1990 [JP] Japan 2-33436

[52] U.S. Cl. D14/138; D12/191; D14/144; D14/240; D14/142

[58] Field of Search D14/138, 240, 140, 144; D12/191; 364/708; 379/440, 428, 110

[56] References Cited

U.S. PATENT DOCUMENTS

D. 281,974	12/1985	Suzuki et al.	D14/138
D. 294,495	3/1988	Nissley	D12/191
D. 301,340	5/1989	Pitkonen	D14/217
D. 301,467	6/1989	Pitkonen	D14/138
D. 301,882	6/1989	Watanabe	D14/140
D. 302,271	7/1989	Watanabe	D14/140
D. 311,541	10/1990	Carre	D14/240
D. 315,890	4/1991	Lewo	D12/191
D. 316,242	4/1991	Lewo	D12/191
D. 317,762	6/1991	Watanabe	D14/138
4,875,229	10/1989	Palett et al.	D14/138 X
4,897,873	1/1990	Beutler et al.	379/433
4,918,631	4/1990	Hara et al.	364/708
5,014,346	5/1991	Phillips et al.	379/433

FOREIGN PATENT DOCUMENTS

708271	3/1987	Japan .
708272	3/1987	Japan .
751103	9/1988	Japan .
754954	11/1988	Japan .
761280	2/1989	Japan .

Primary Examiner—Horace B. Fay, Jr.
Attorney, Agent, or Firm—Wenderoth, Lind & Ponack

[57] CLAIM

The ornamental design for an automotive telephone control unit, as shown and described.

DESCRIPTION

FIGS. 1 and 2 are respectively front and rear elevational views of an automotive telephone control unit showing my new design;

FIGS. 3 and 4 are respectively top and bottom plan views thereof;

FIGS. 5 and 6 are respectively left and right side elevational views thereof;

FIG. 7 is a front and right side perspective view showing the control unit in electrified status;

FIGS. 8 and 9 are respectively sectional views taken on the lines VII—VIII and IV—IV in FIG. 3; and,

FIG. 10 is a bracket associated view thereof, with the top peripheral frame spaced apart from the main body to show how the assembled control unit fits upon the vehicle sun visor.

The broken line showing of numerals, words, letters, abbreviated words, and symbols in FIG. 7 is for illustrative purposes only and forms no part of the claimed design.

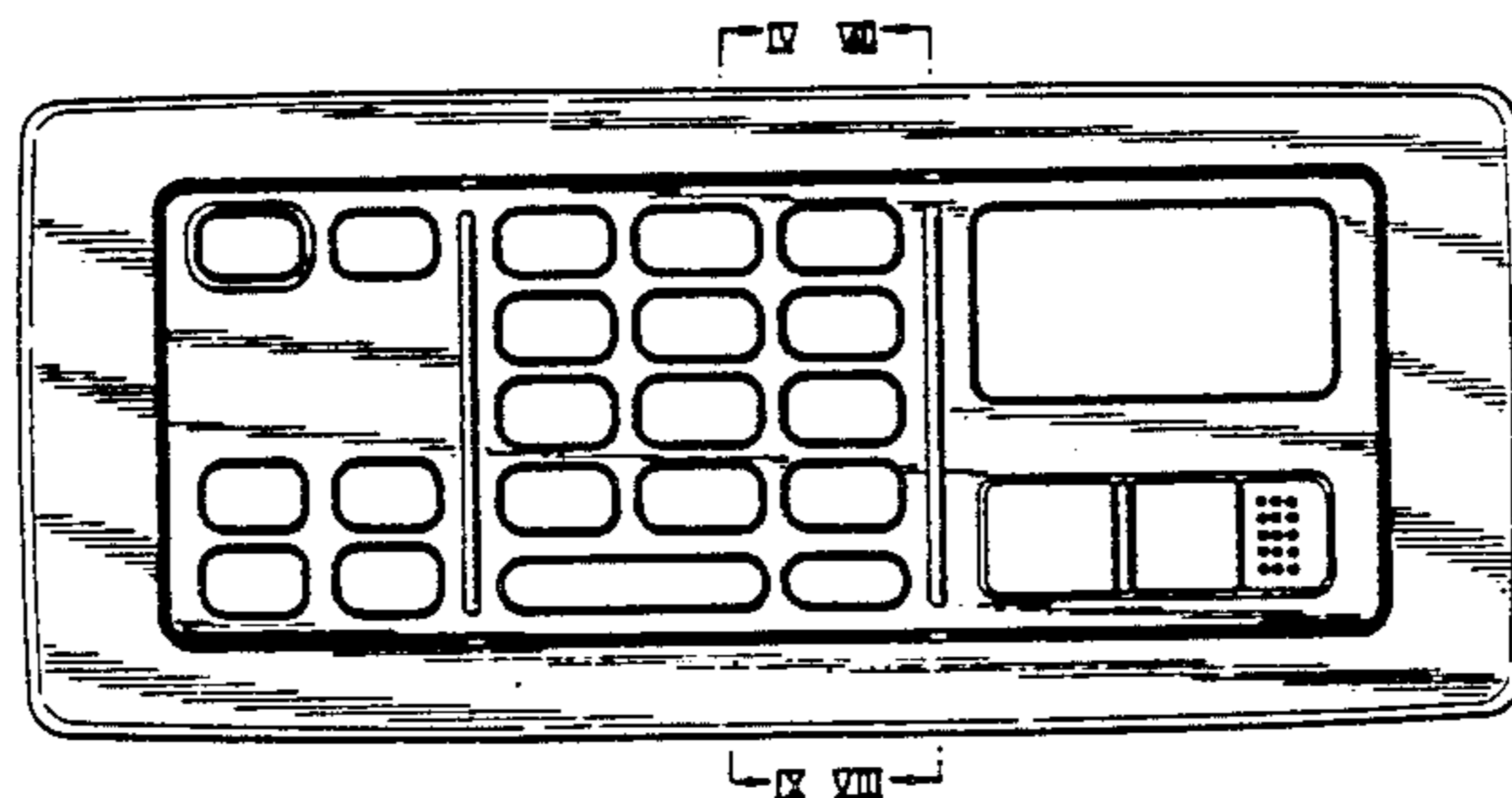
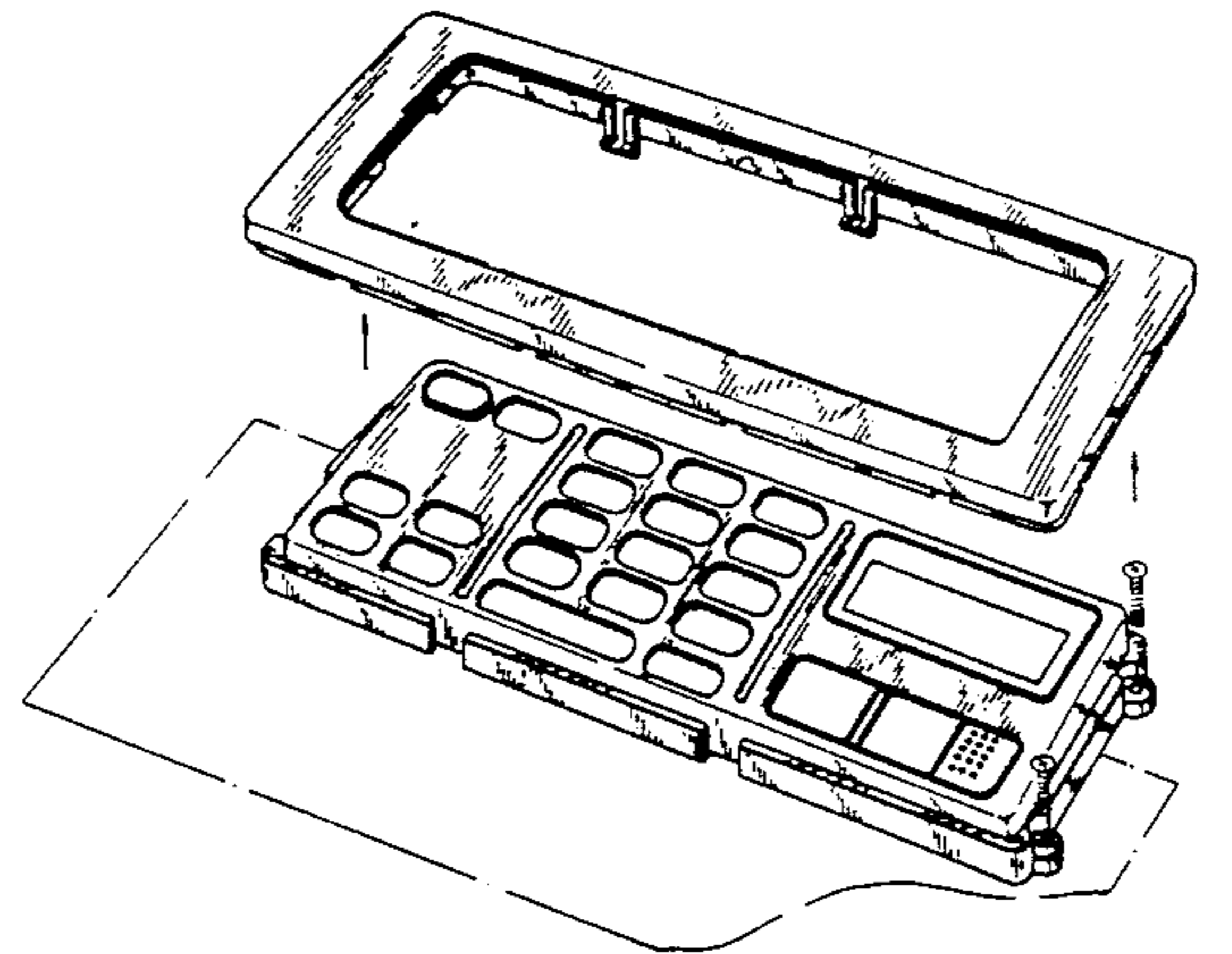

Fig. 1

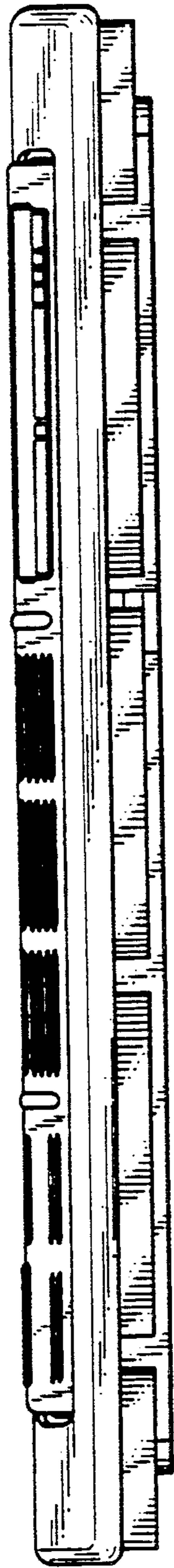

Fig. 2

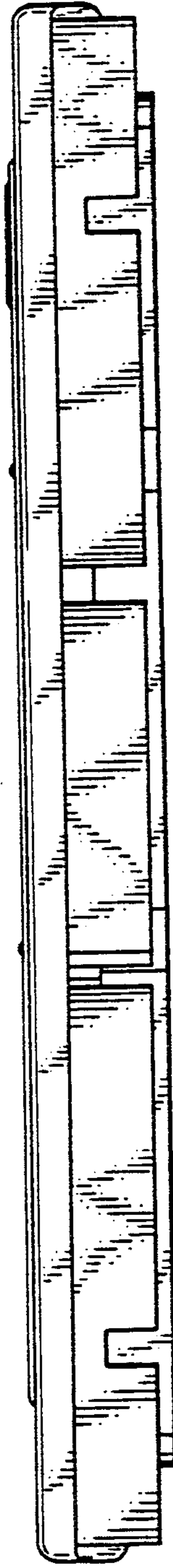

Fig. 3

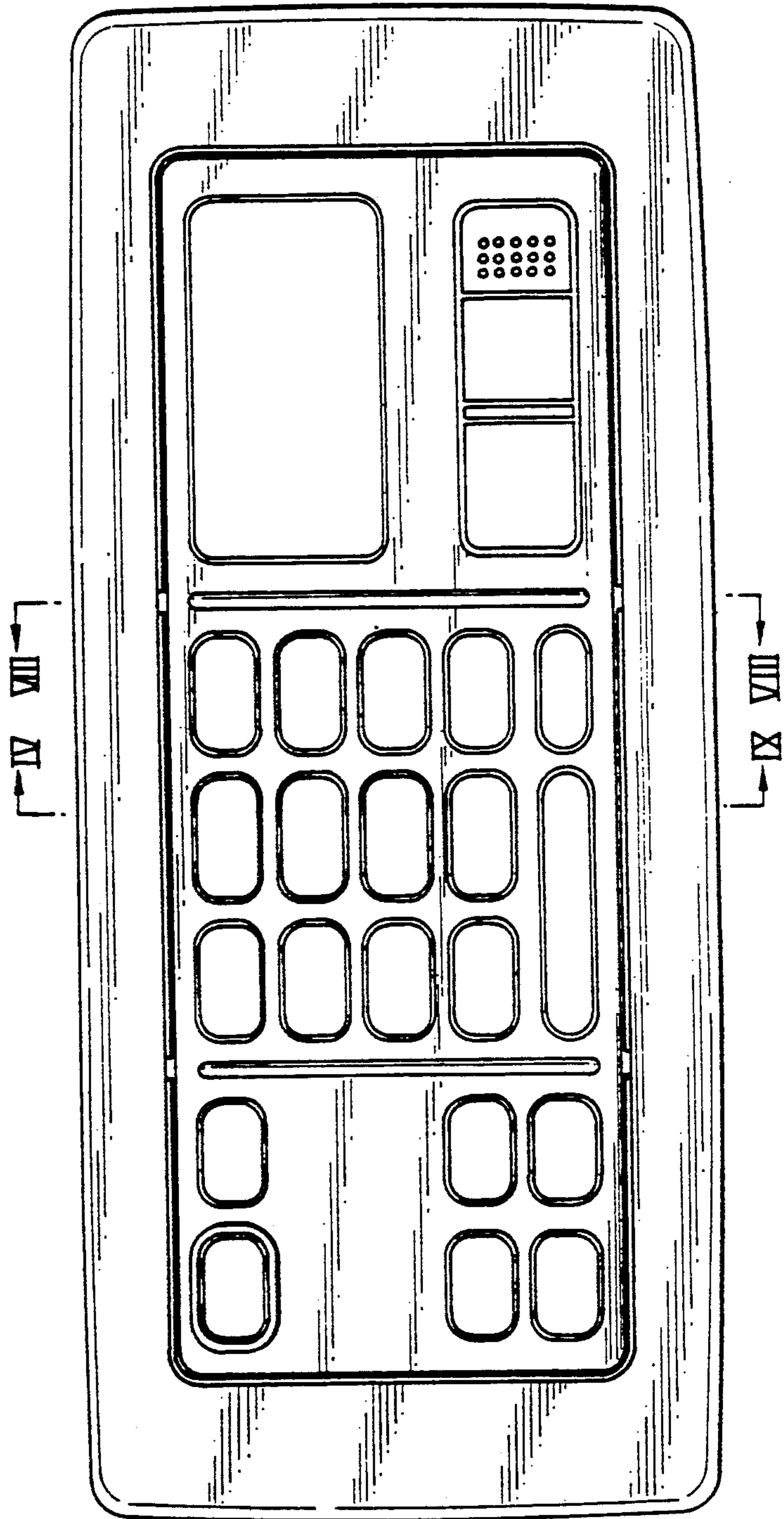

Fig.4

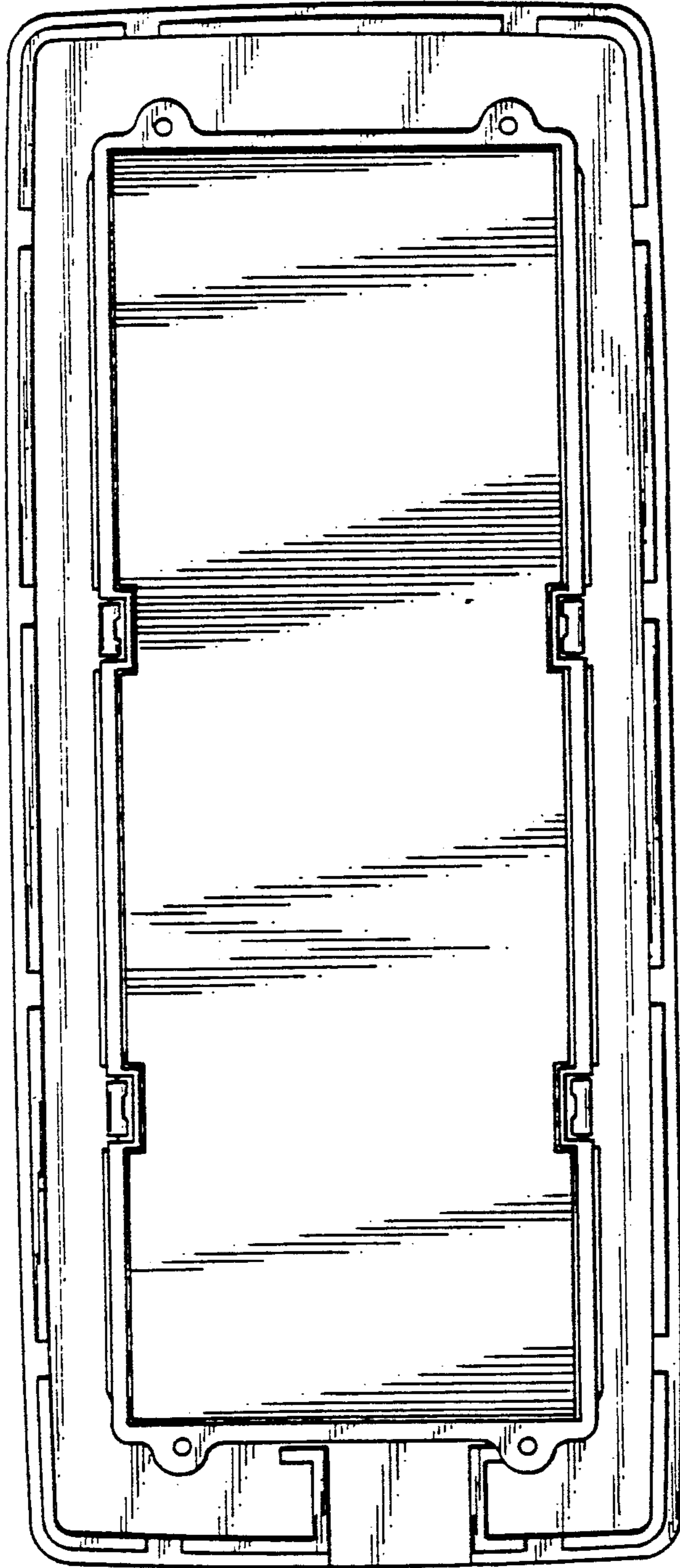

Fig.5

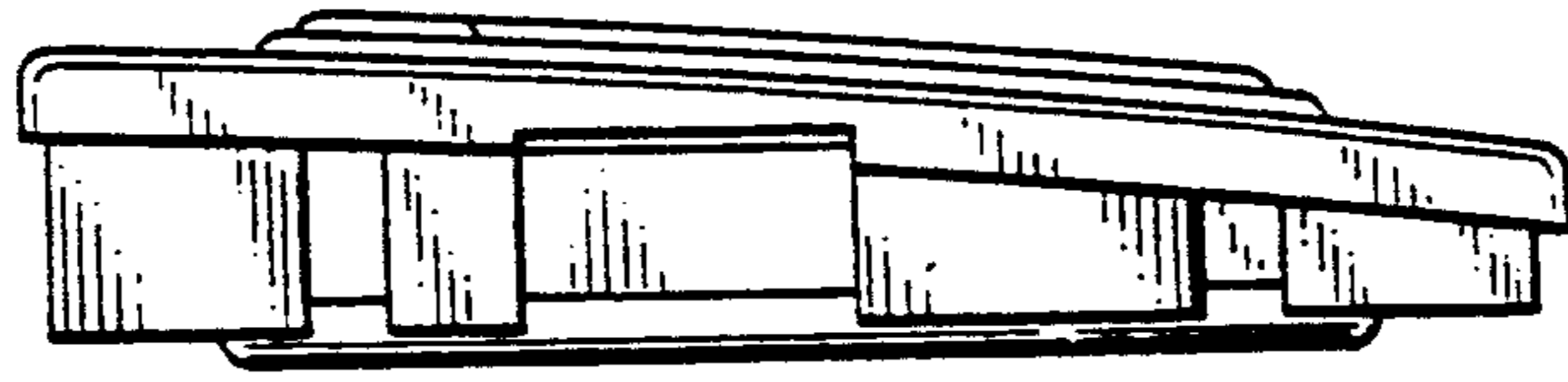

Fig.6



Fig. 7

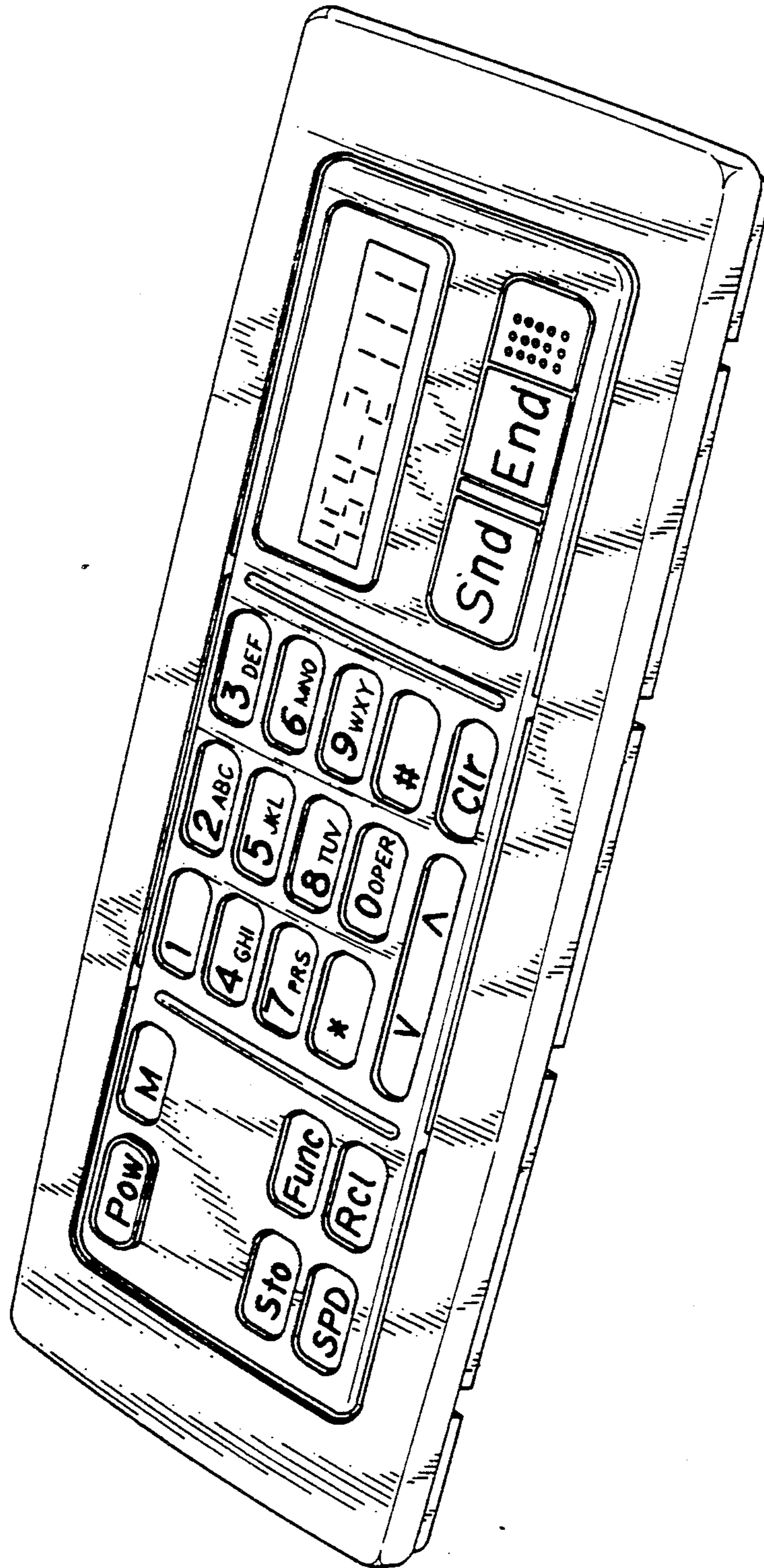

Fig.8

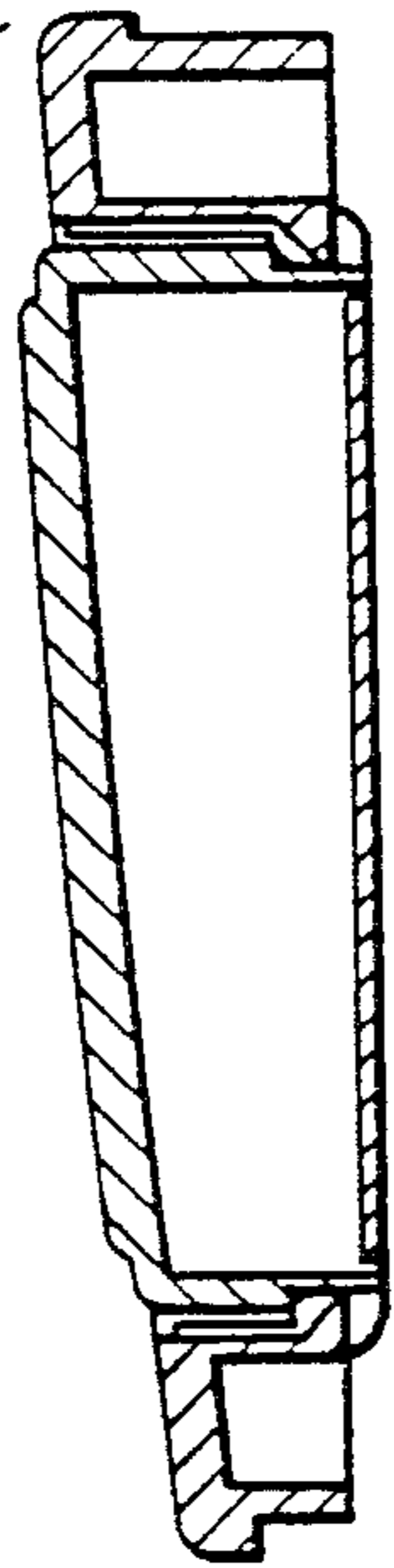
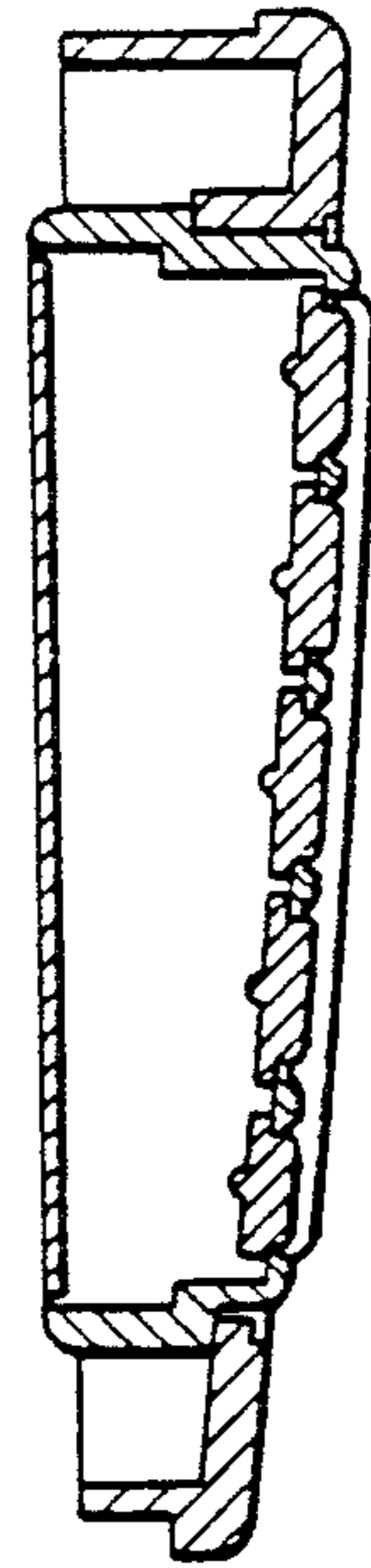

Fig.9



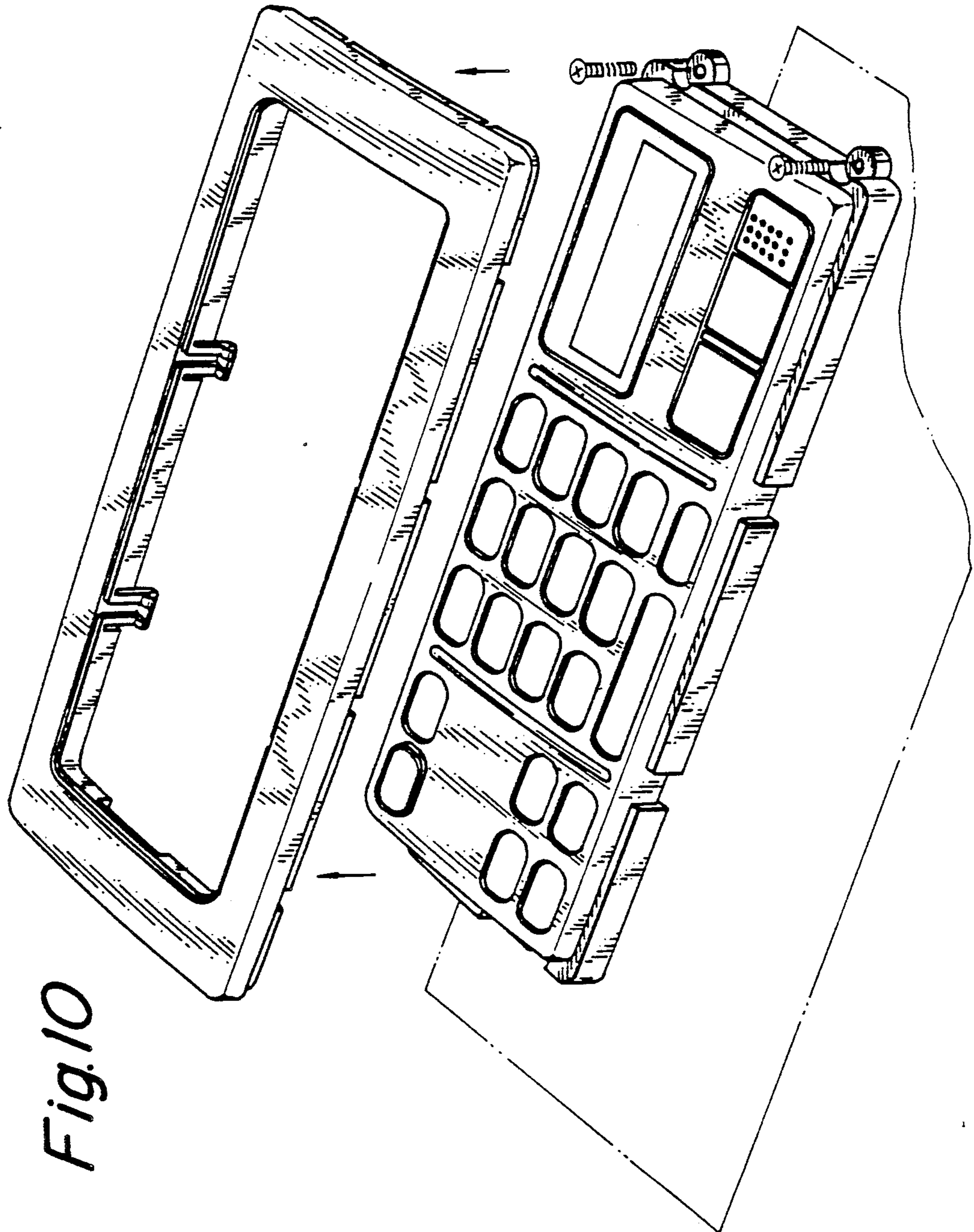

Fig.10