



US00D326435S

# United States Patent [19] Park

[11] Patent Number: **Des. 326,435**

[45] Date of Patent: **\*\* May 26, 1992**

[54] PASSENGER CAR

[75] Inventor: **Tae K. Park**, Ulsan, Rep. of Korea

[73] Assignee: **Hyundai Motor Company**, Seoul, Rep. of Korea

[\*\*] Term: **14 Years**

[21] Appl. No.: **307,592**

[22] Filed: **Feb. 8, 1989**

[30] Foreign Application Priority Data

Nov. 4, 1988 [KR] Rep. of Korea ..... 88-14987

[52] U.S. Cl. .... **D12/92**

[58] Field of Search ..... D12/91, 92; 296/185

[56] References Cited

### U.S. PATENT DOCUMENTS

D. 297,523 9/1988 Yamamoto ..... D12/92

D. 298,423 11/1988 Park ..... D12/91

D. 298,424 11/1988 Park ..... D12/91

### OTHER PUBLICATIONS

Road & Track, Jan. 1988, p. 114, Hyundai Automobile, center of page.

1987 Volkswagen brochure, p. 7, Volkswagen Scirocco, top of page.

Road & Track, Aug. 1988, p. 102, Ford Thunderbird, top of page.

Motor Trend, Jan. 1988, p. 13, Honda Accord Coupe, top of page.

*Primary Examiner*—James M. Gandy

*Attorney, Agent, or Firm*—Birch, Stewart, Kolasch & Birch

[57] **CLAIM**

The ornamental design for a passenger car, as shown.

### DESCRIPTION

FIG. 1 is a perspective view of the passenger car;

FIG. 2 is a front elevational view thereof;

FIG. 3 is a back elevational view thereof;

FIG. 4 is a top plan view thereof;

FIG. 5 is a left side elevational view thereof; and,

FIG. 6 is a right side elevational view thereof.

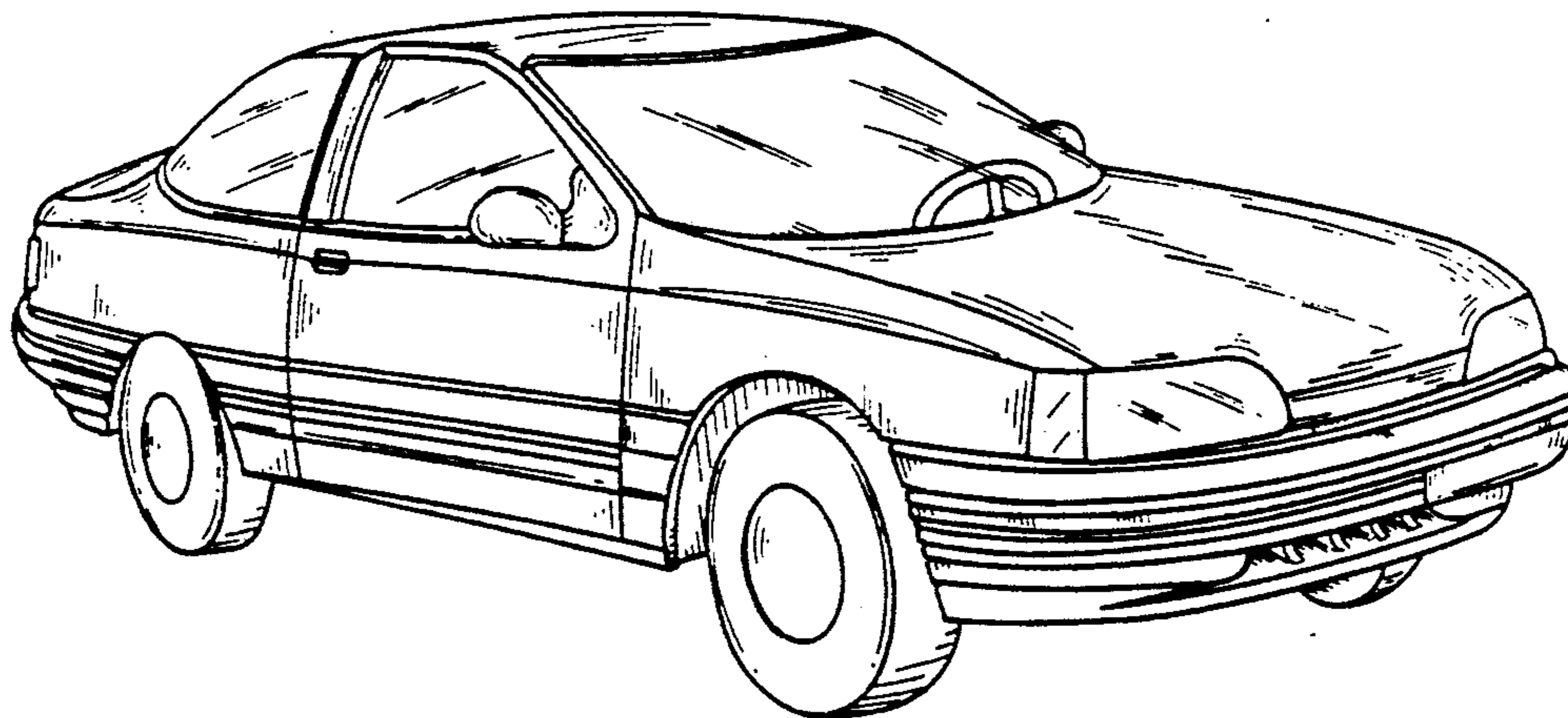

FIG. 1

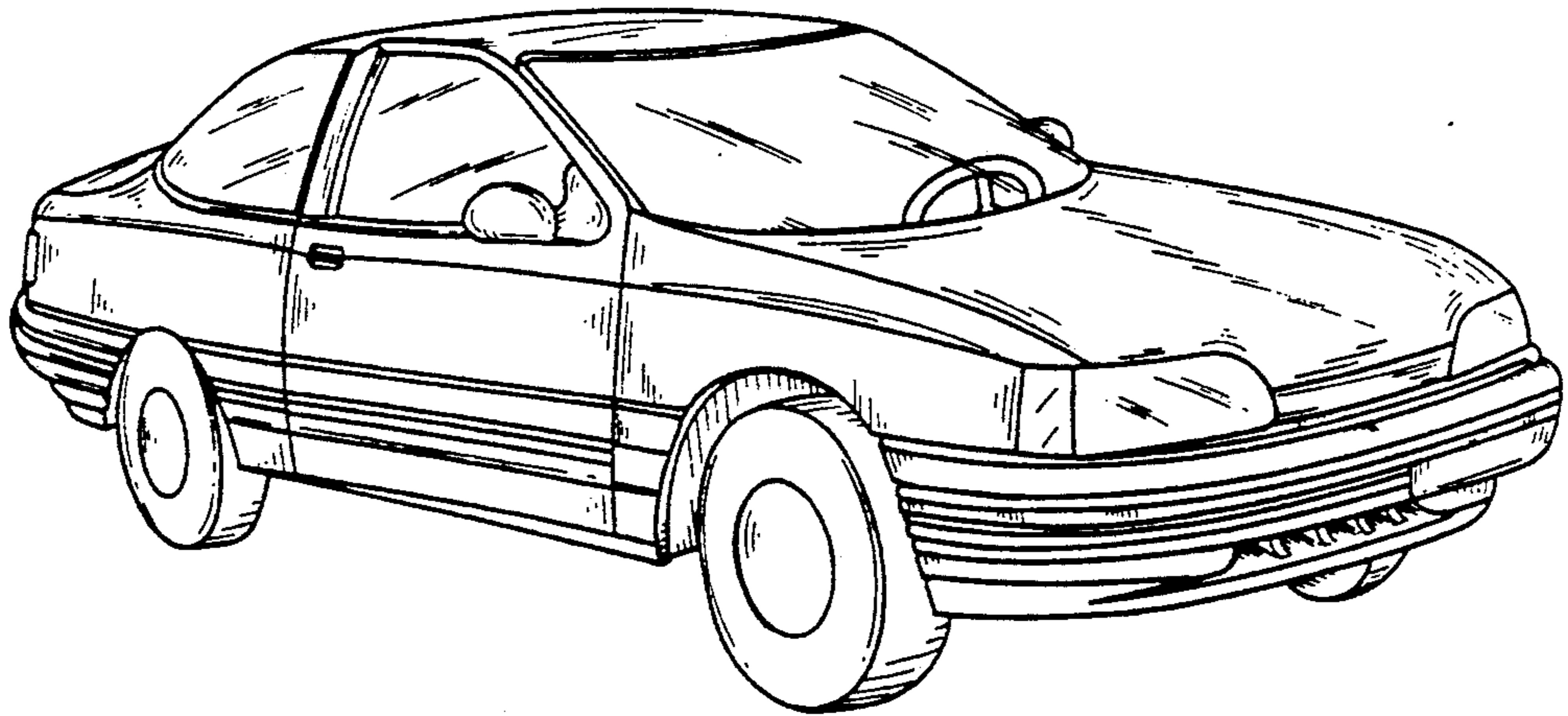

FIG. 2

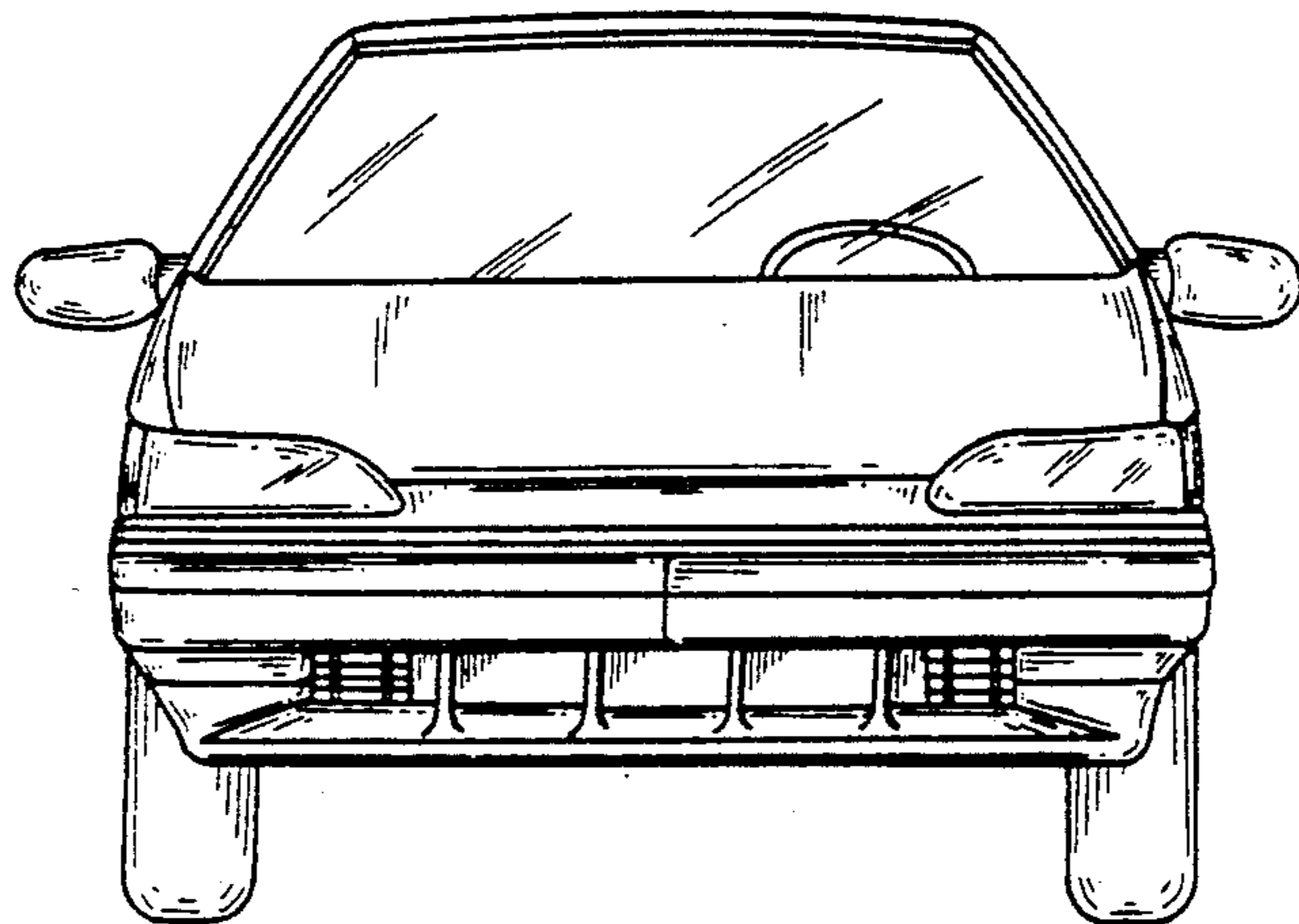

FIG. 3

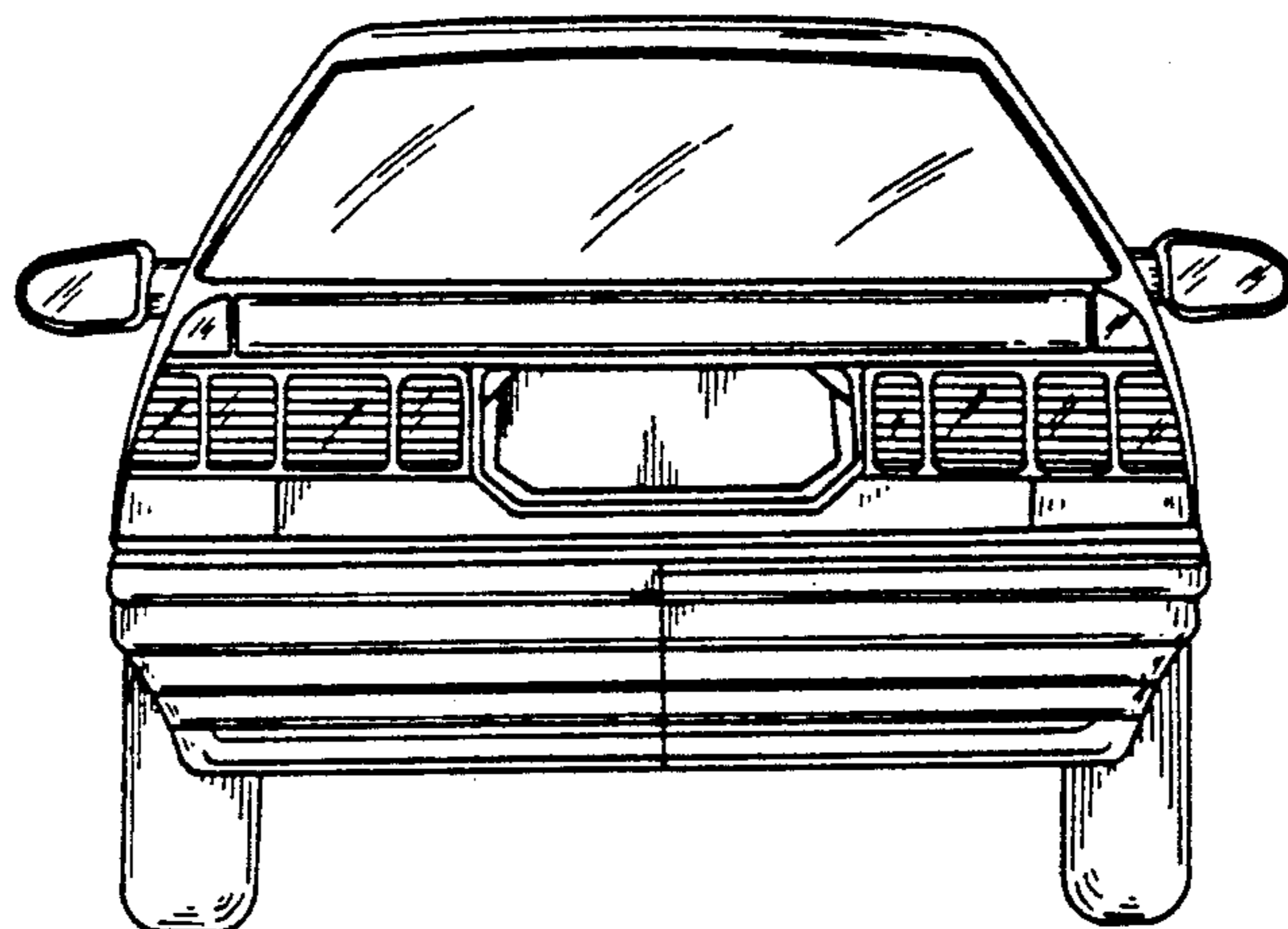

FIG. 4

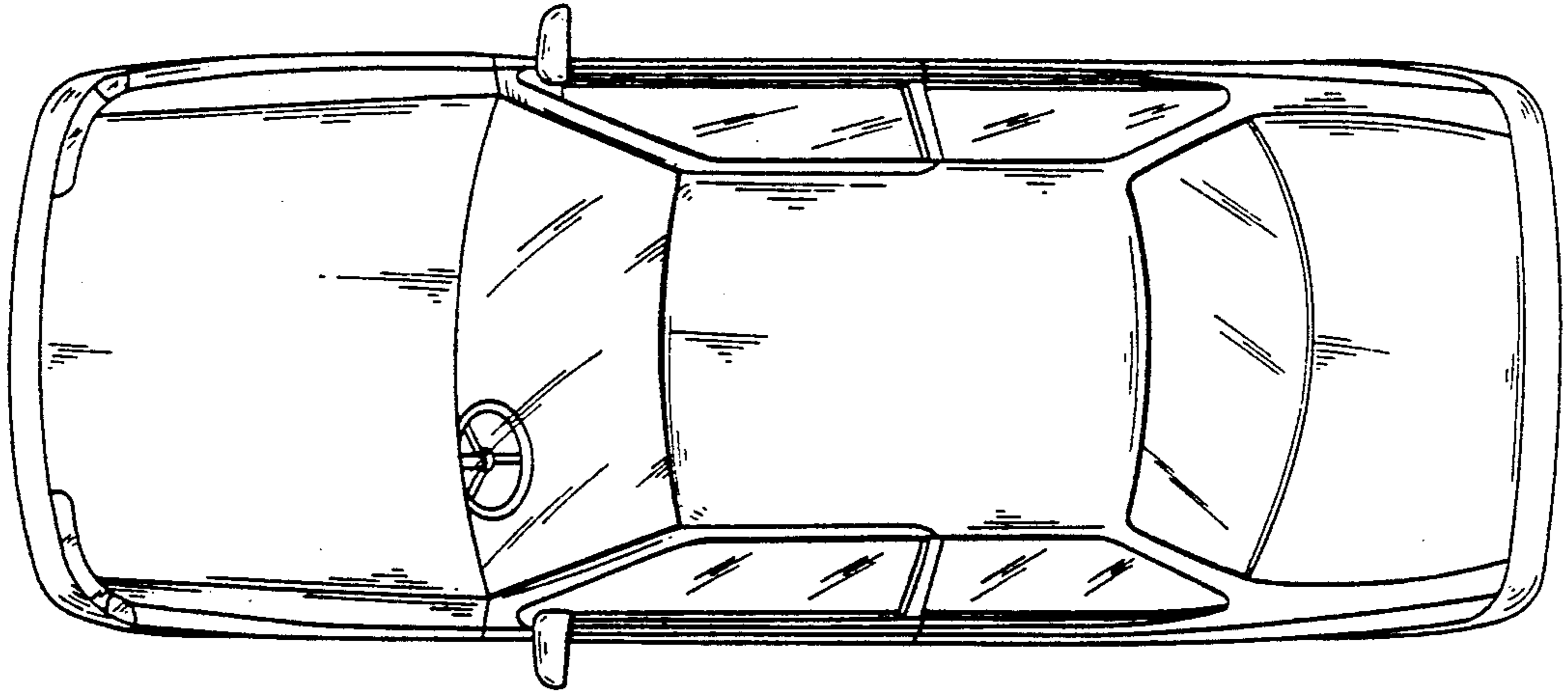

FIG. 5

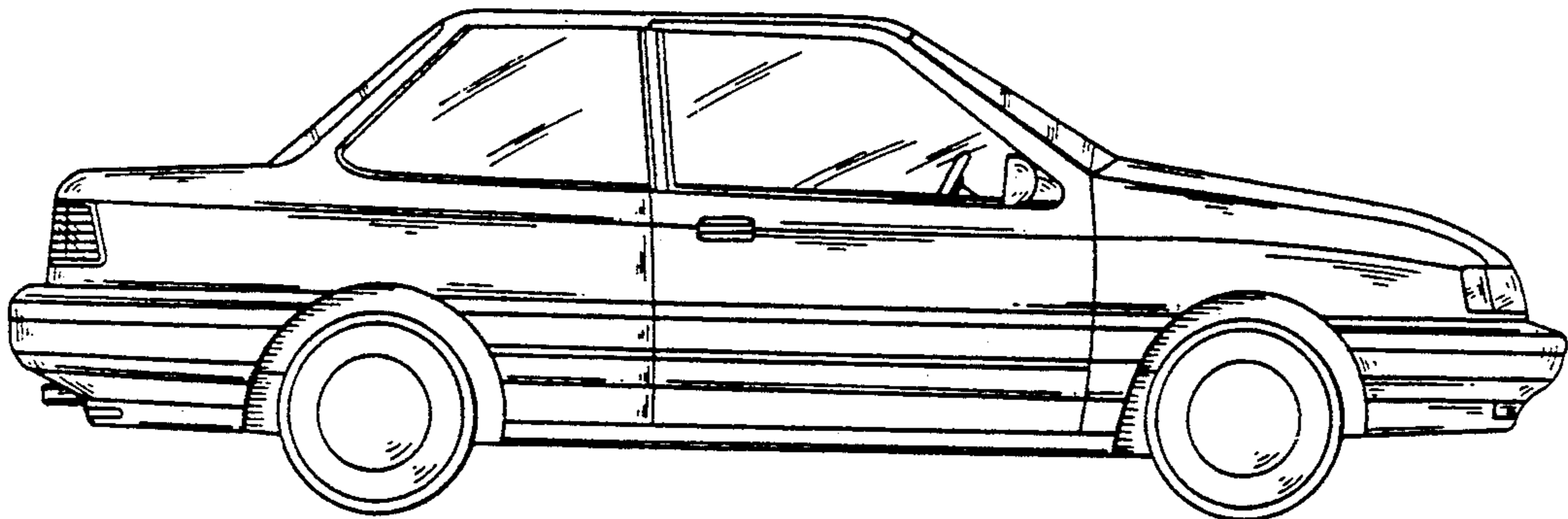

FIG. 6

