



US00D326377S

# United States Patent [19]

[11] Patent Number: Des. 326,377

Nagel

[45] Date of Patent: \*\* May 26, 1992

[54] DISPLAY RACK FOR AUDIO VIDEO EQUIPMENT

1,643,477	9/1927	Warren	.....	211/50	X
2,143,592	1/1939	Baldeck	.....	D6/474	X
3,479,990	11/1969	Crow	.....	D6/474	X
3,479,991	11/1969	Lichenberger	.....	D6/474	X

[75] Inventor: Richard Nagel,  
Rethorn-Ganderkese, Fed. Rep. of Germany

Primary Examiner—Donald P. Walsh  
Assistant Examiner—Jeffrey Asch  
Attorney, Agent, or Firm—Merchant, Gould, Smith,  
Edell, Welter & Schmidt

[73] Assignee: Structura Raum- und Lichtelemente  
Vertriebsgesellschaft mbH & Co. KG,  
Bremen, Fed. Rep. of Germany

[\*\*] Term: 14 Years

### [57] CLAIM

[21] Appl. No.: 162,748

The ornamental design for a display rack for audio video equipment, as shown and described.

[22] Filed: Mar. 1, 1988

### DESCRIPTION

[52] U.S. Cl. .... D6/461; D6/460;  
D6/477

[58] Field of Search ..... D6/474, 477, 478, 479,  
D6/455, 458, 457, 459, 460, 461, 449, 412;  
211/163, 77, 78, 50, 13

FIG. 1 is a front elevational view of a display rack for audio video equipment showing my new design;  
FIG. 2 is a rear elevational view;  
FIG. 3 is a right side elevational view, the left side being a mirror image thereof;  
FIG. 4 is a top plan view;  
FIG. 5 is a bottom plan view;  
FIG. 6 is a top, front and right side perspective view;  
and,  
FIG. 7 is a top and front perspective view thereof.

### [56] References Cited

#### U.S. PATENT DOCUMENTS

D. 183,995	11/1958	McCartan	.....	D6/461	X
D. 250,372	11/1978	Szabo et al.	.....	D6/474	X

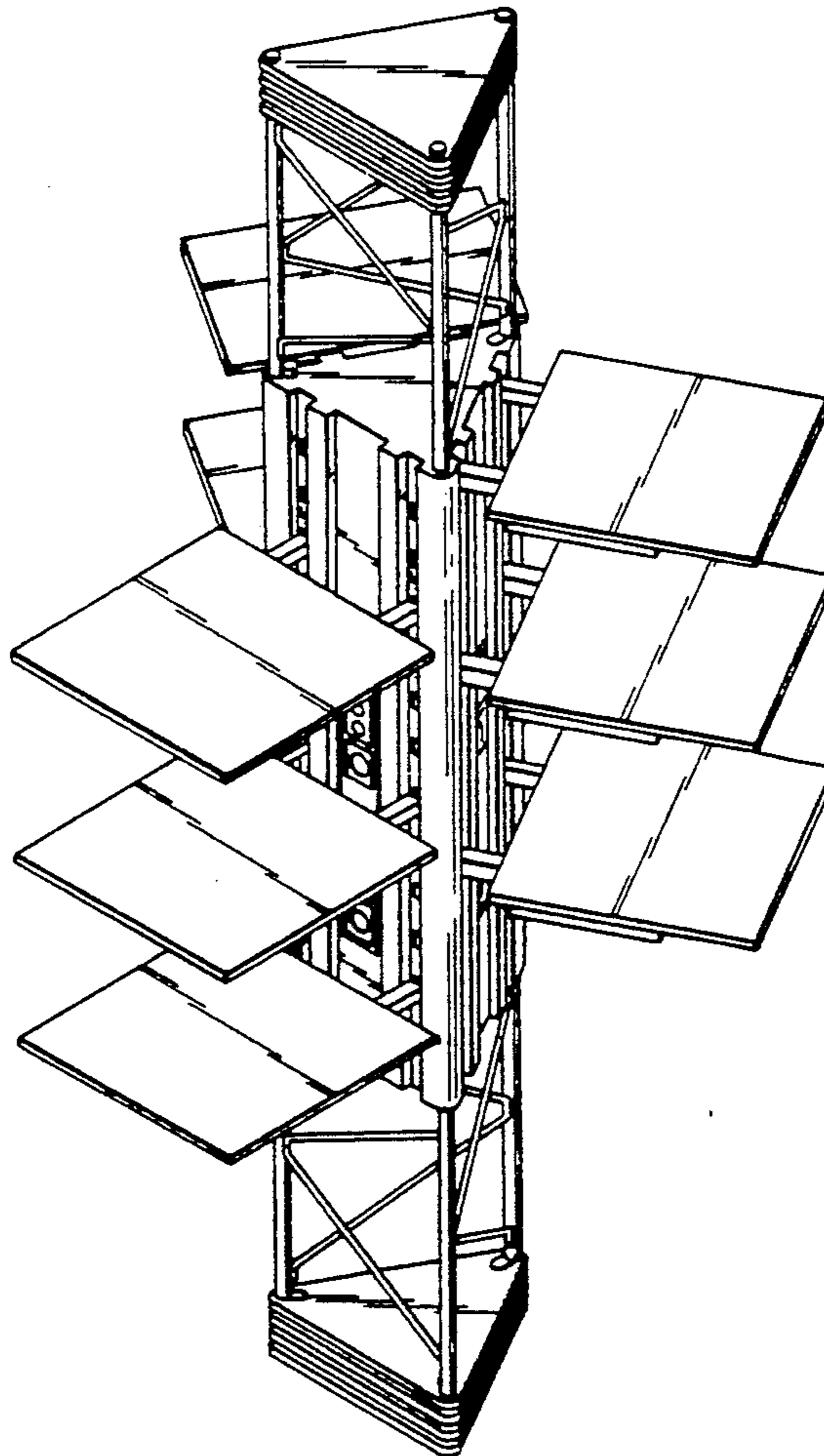

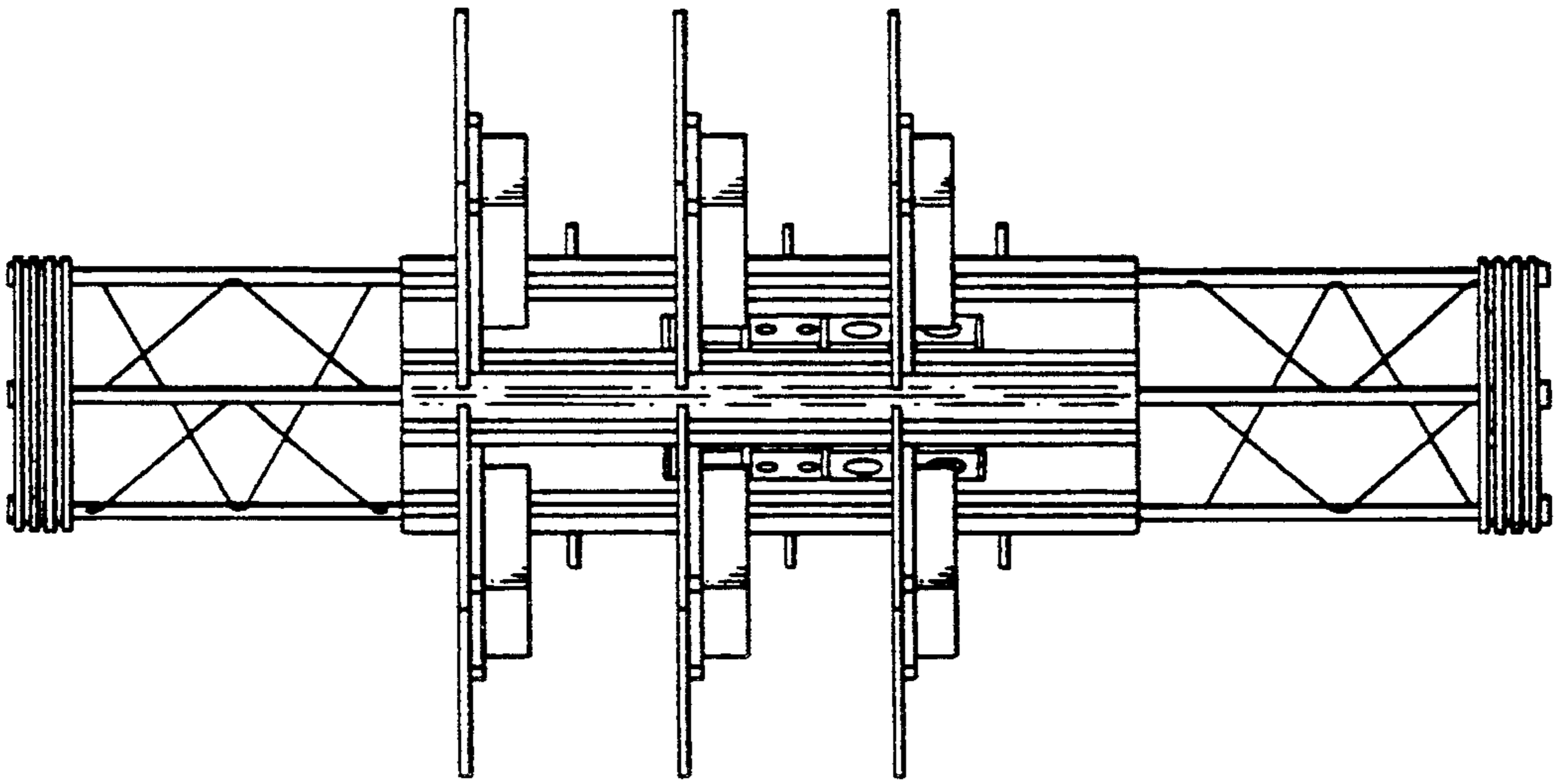

FIG. 2

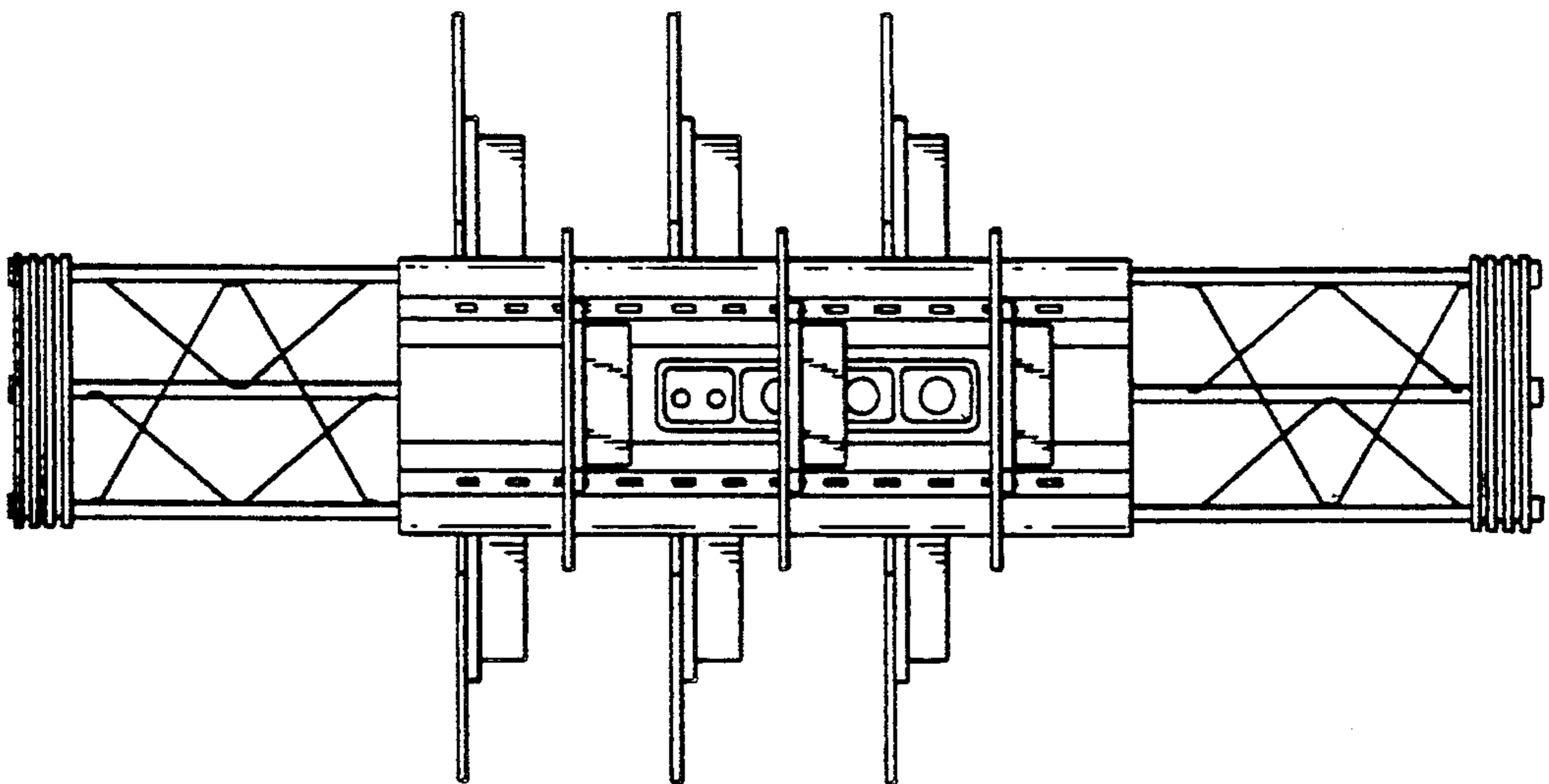

FIG. 1

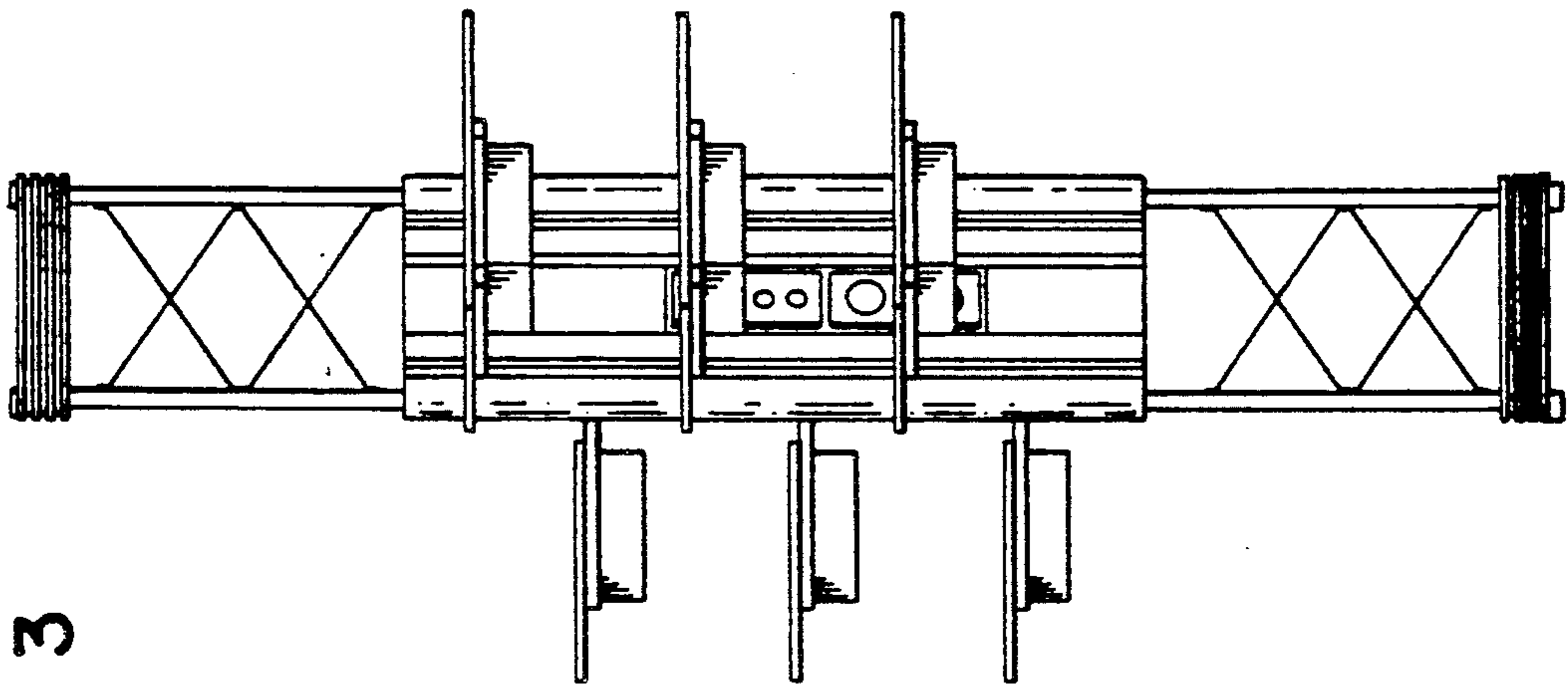

FIG. 3

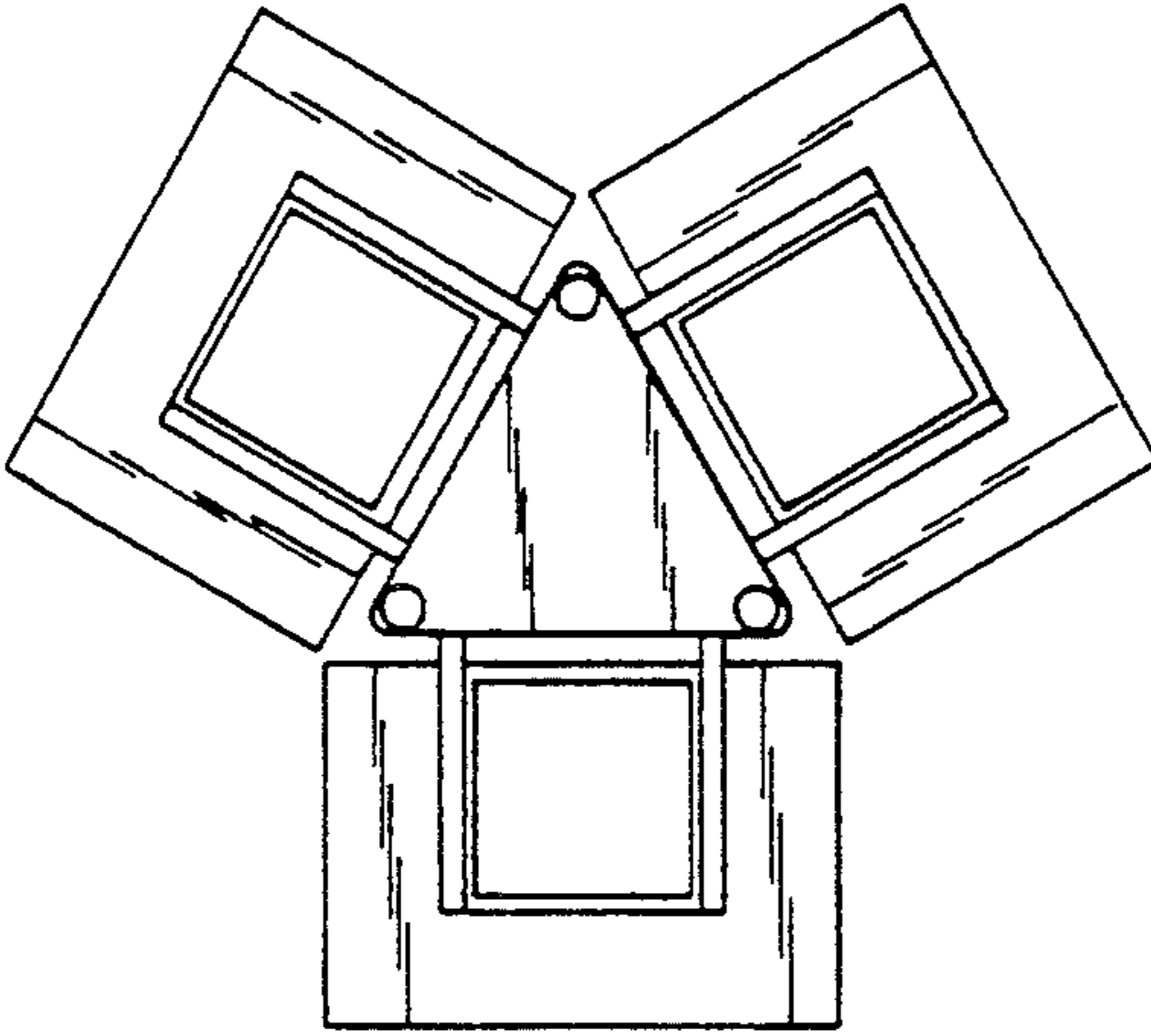

FIG. 5

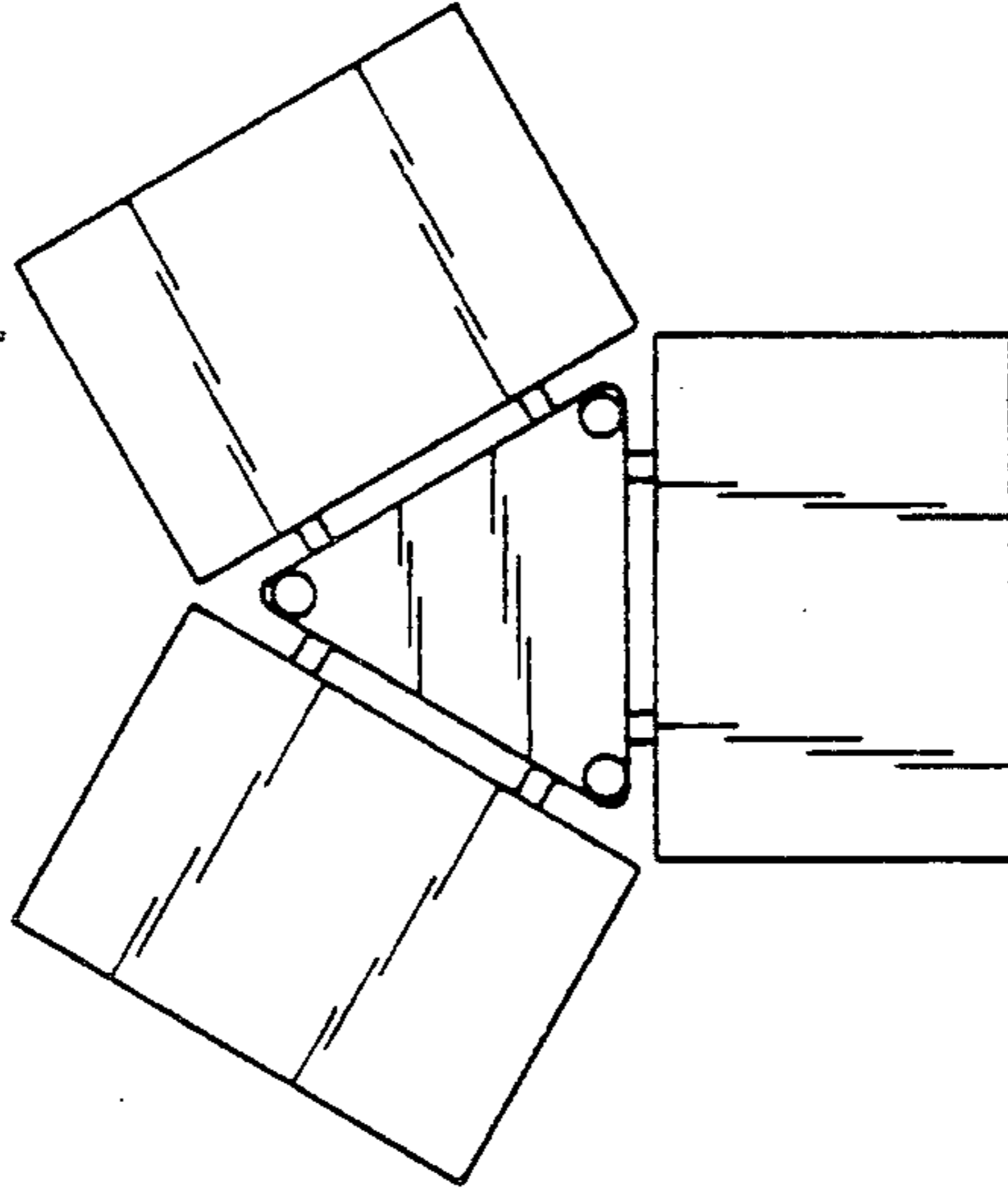

FIG. 4

FIG. 6

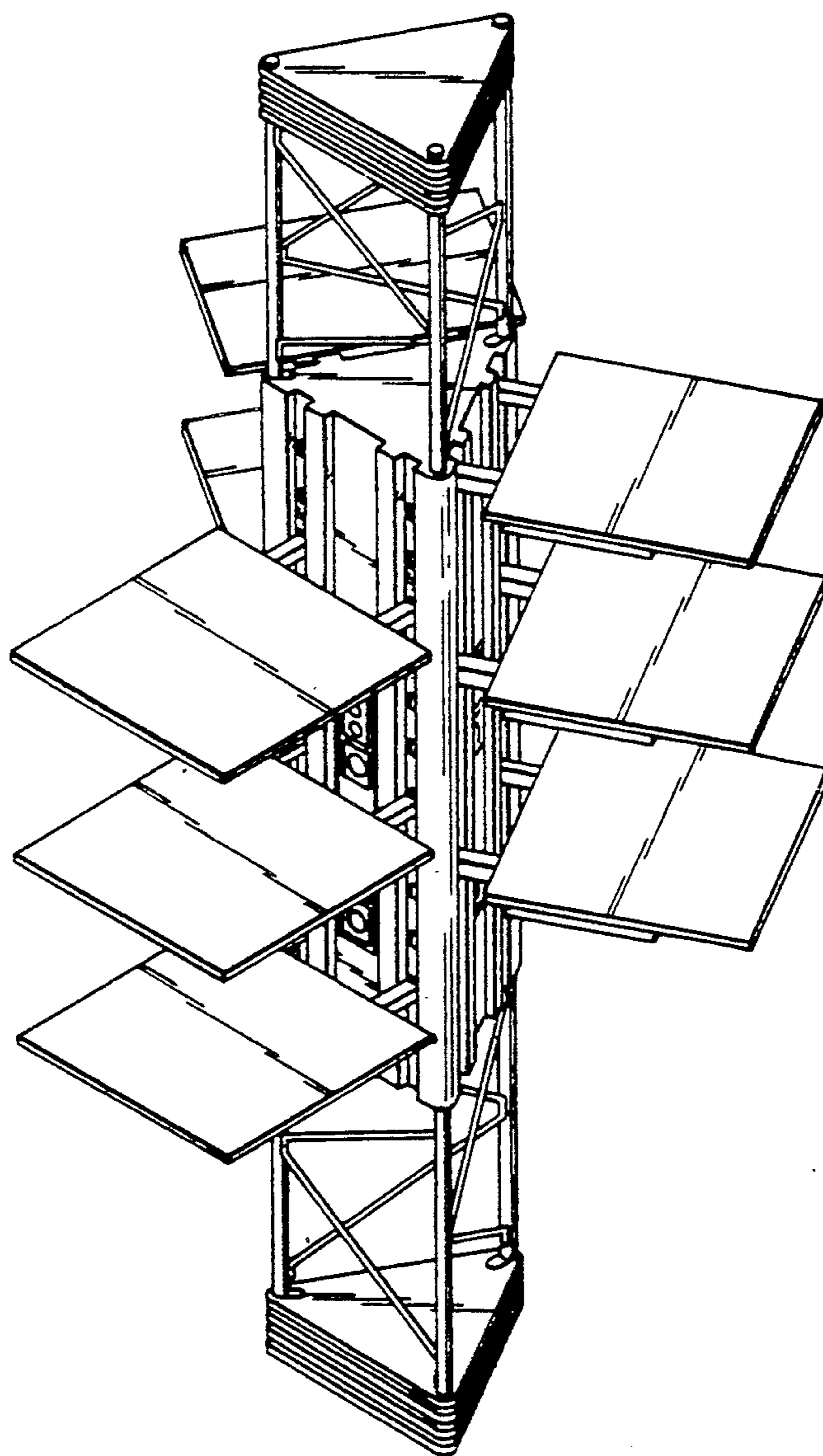

FIG. 7

