



US00D326255S

United States Patent [19]

[11] Patent Number: **Des. 326,255**

Graham et al.

[45] Date of Patent: **** May 19, 1992**

[54] AIRCRAFT

[75] Inventors: **Arthur D. B. Graham**, Mosman Park, Australia; **John G. Roncz**, Granger, Ind.; **Graham Swanell**, Willetton, Australia

[73] Assignee: **Composite Industries Limited**, Australia

[**] Term: **14 Years**

[21] Appl. No.: **249,075**

[22] Filed: **Sep. 23, 1988**

[52] U.S. Cl. **D12/331; D12/319**

[58] Field of Search **D12/319, 331, 332, 324, D12/326, 344; 244/13, 16, 45 A, 45 R**

[56] References Cited

U.S. PATENT DOCUMENTS

D. 311,719 10/1990 Haga D12/331

OTHER PUBLICATIONS

Flight International, Feb. 20, 1988, p. 18, "Eagle X2" light aircraft.

Primary Examiner—Kay H. Chin
Attorney, Agent, or Firm—Eckert Seamans Cherin & Mellott

[57] CLAIM

The ornamental design for an aircraft, as shown and described.

DESCRIPTION

FIG. 1 is a top, front and left side perspective view of an aircraft showing our new design;

FIG. 2 is a top, rear and right side perspective view thereof;

FIG. 3 is a bottom and right side perspective view thereof; and,

FIG. 4 is a front elevational view thereof.

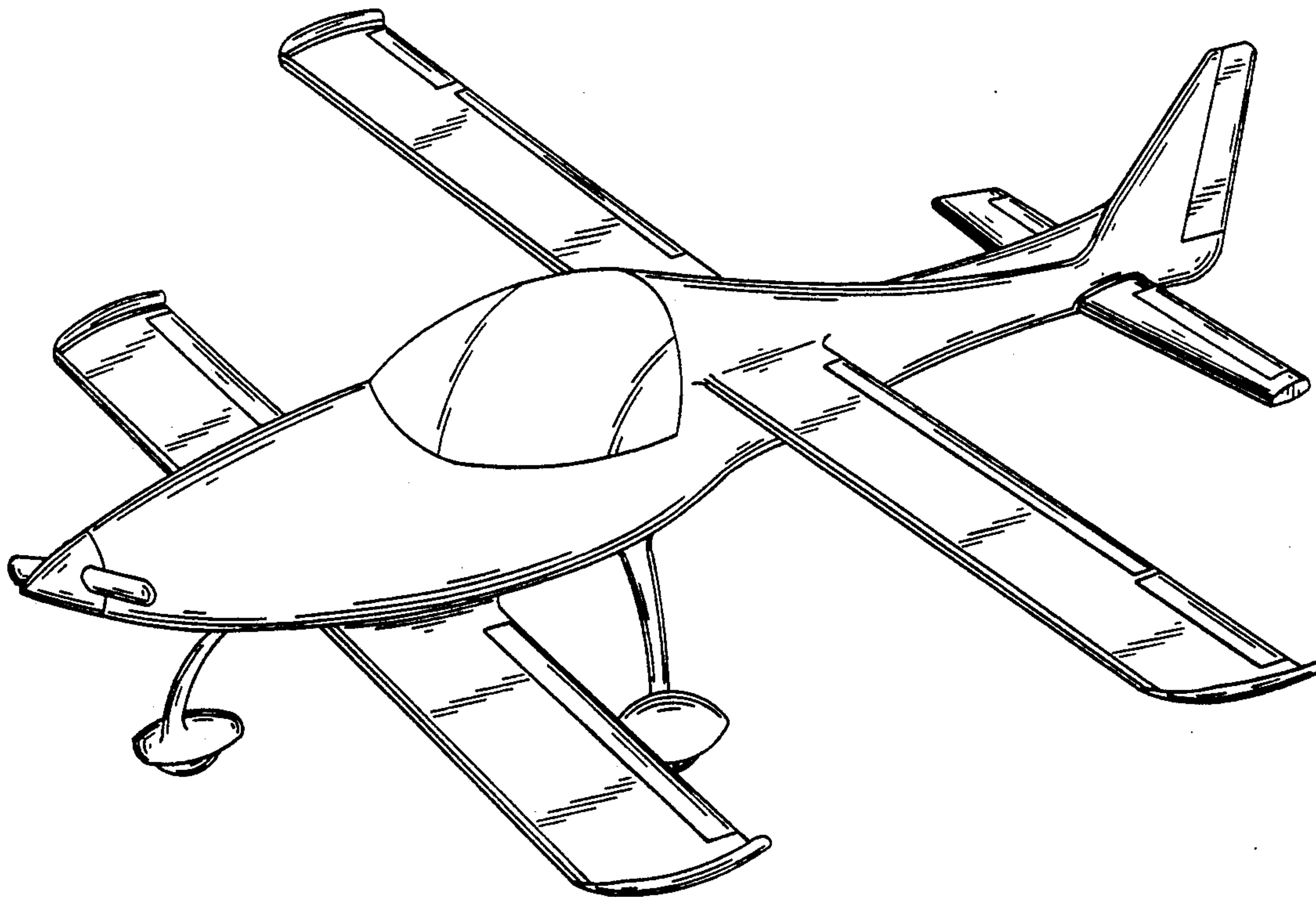

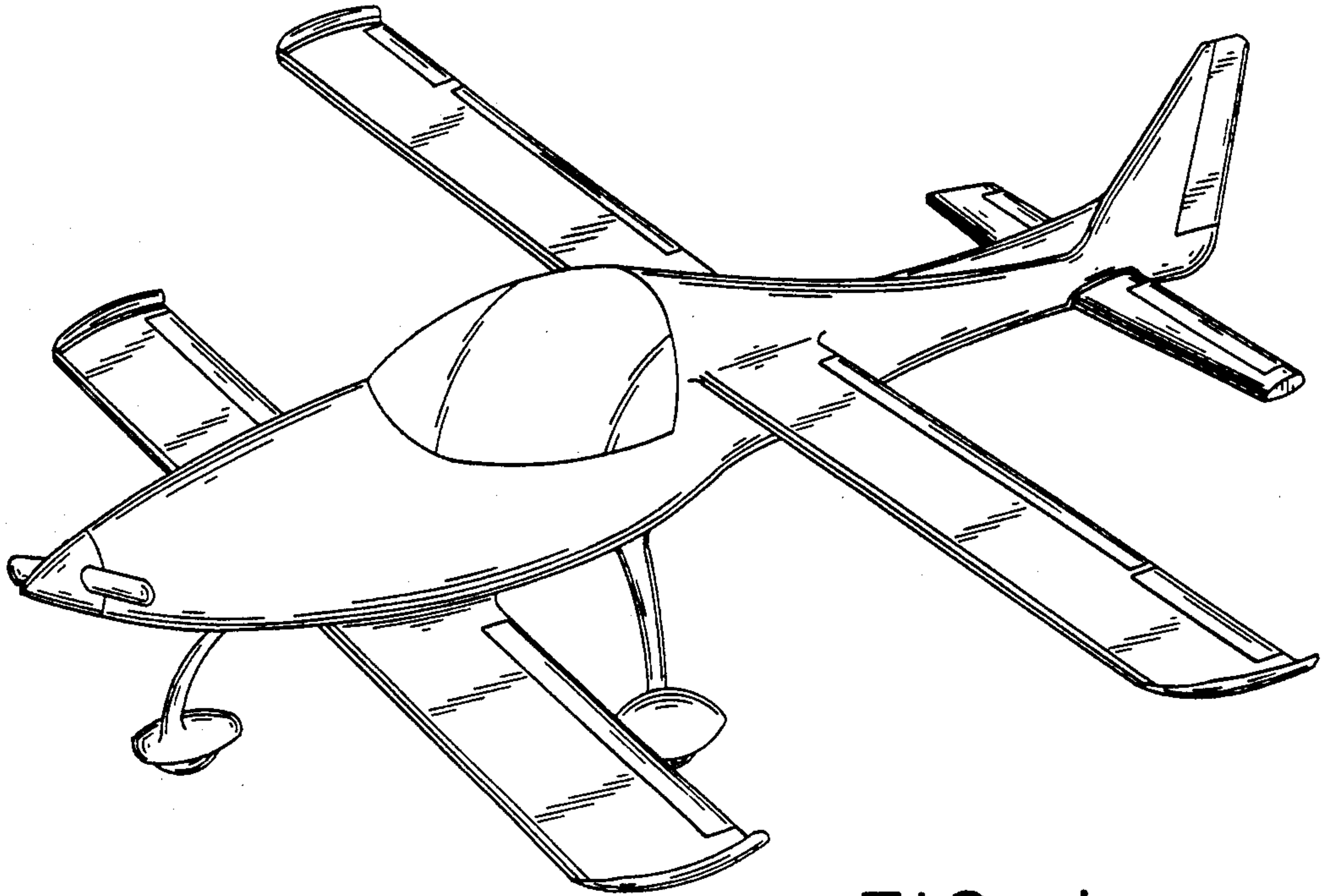

FIG. 1

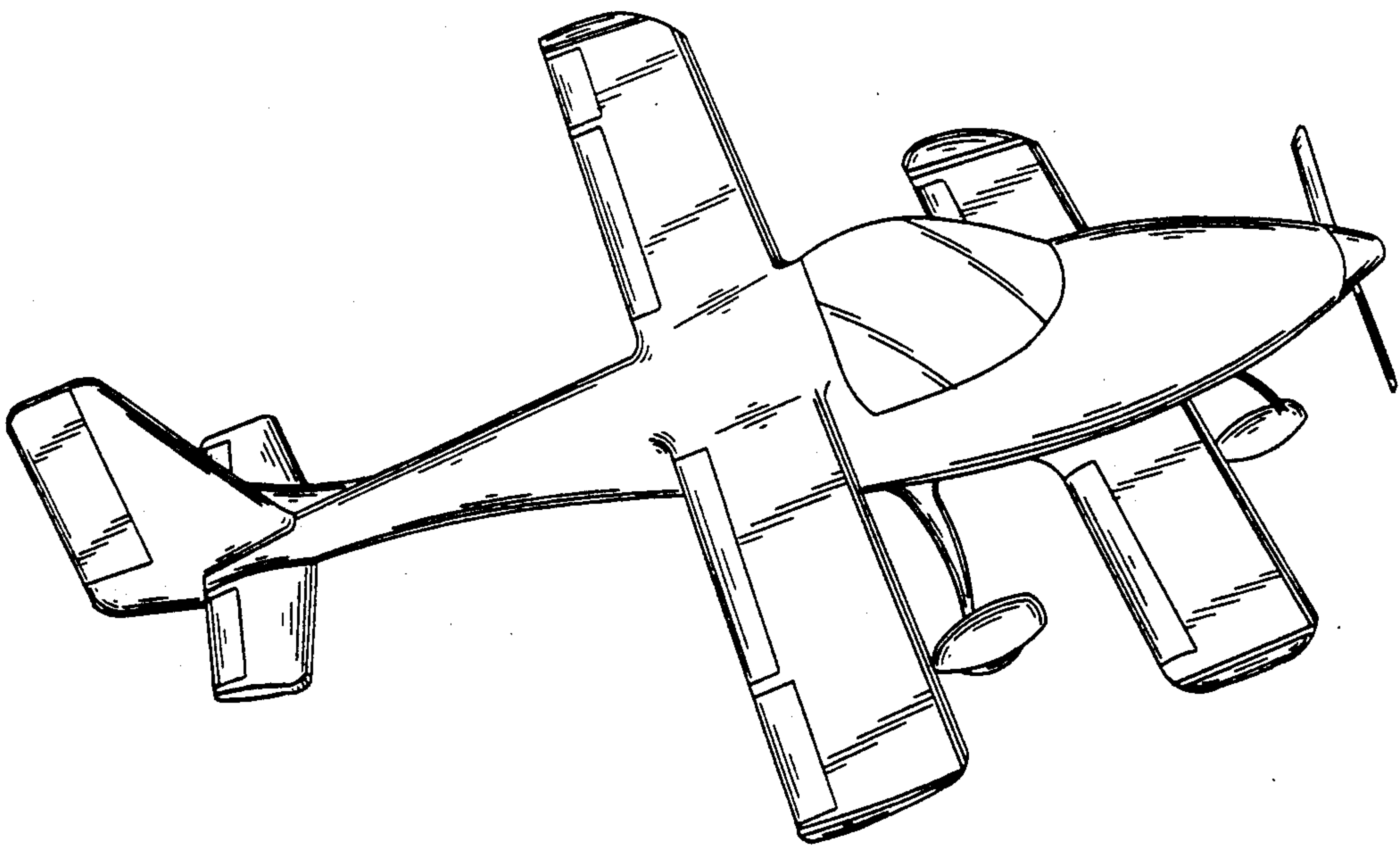

FIG. 2

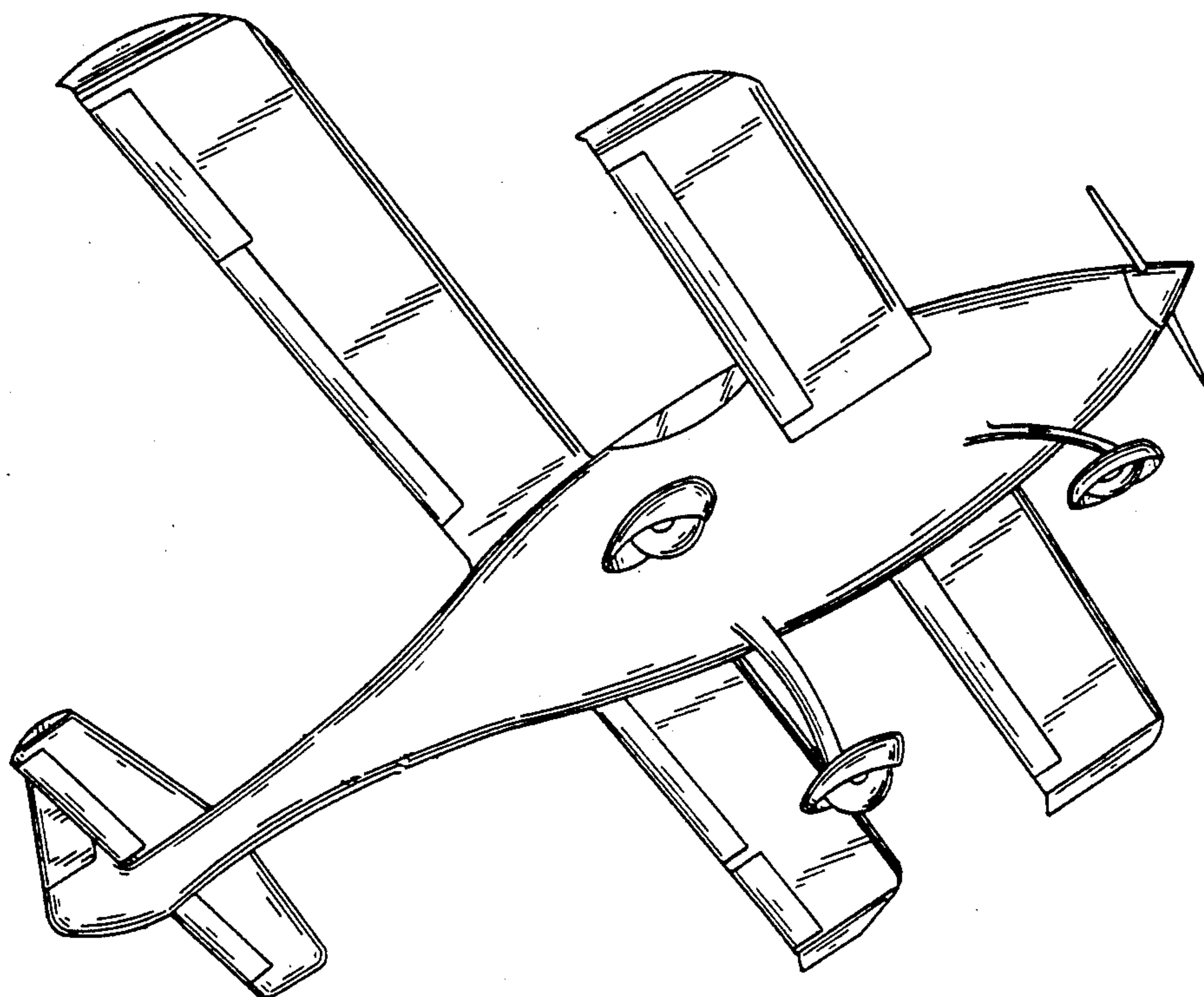

FIG. 3

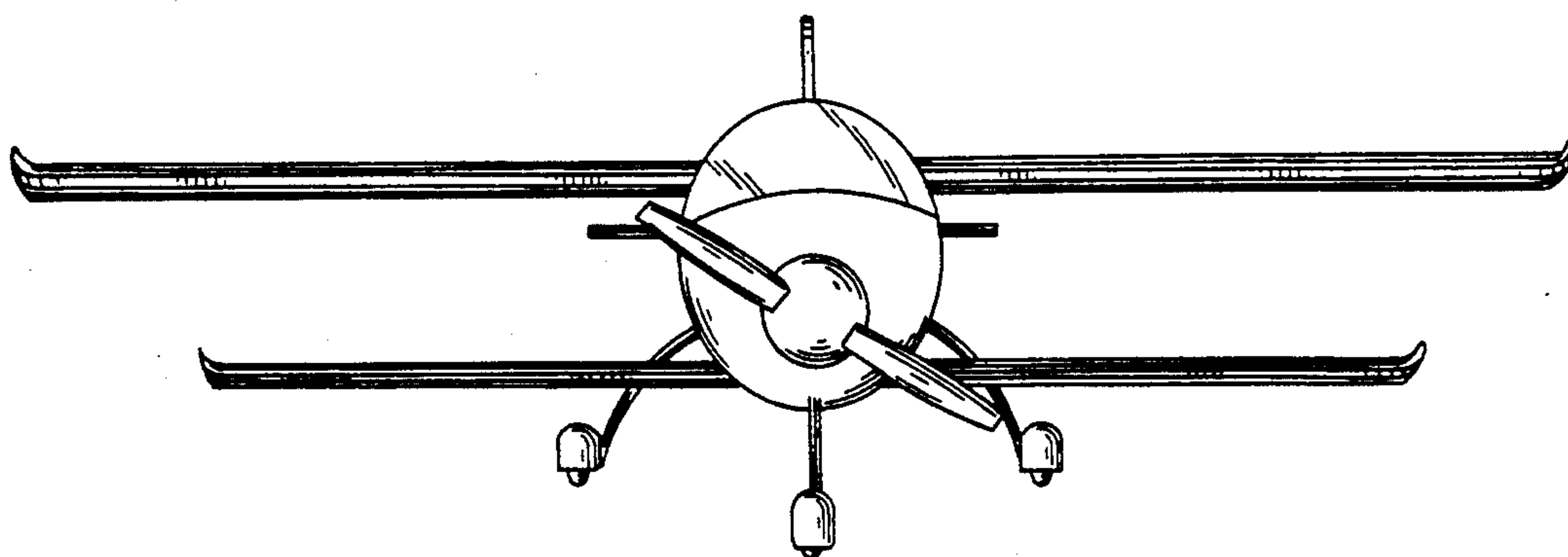

FIG. 4

UNITED STATES PATENT AND TRADEMARK OFFICE
CERTIFICATE OF CORRECTION

PATENT NO. : Des. 326,255

DATED : May 19, 1992

INVENTOR(S) : Arthur D.B. Graham, John G. Roncz,
Graham Swannell

It is certified that error appears in the above-identified patent and that said Letters Patent is hereby corrected as shown below:

On the title page, item (75):

A co-inventor's name is misspelled. The name

"Graham Swanell" should read --Graham Swannell--.

Signed and Sealed this
Sixth Day of July, 1993

Attest:



MICHAEL K. KIRK

Attesting Officer

Acting Commissioner of Patents and Trademarks