



US00D326078S

United States Patent [19]

[11] Patent Number: **Des. 326,078**

Rogers

[45] Date of Patent: **** May 12, 1992**

[54] SPOILER FOR A TRUCK CAP

[76] Inventor: **Charles R. Rogers**, 8696 Spinnaker Way, Apt. C1, Ypsilanti, Mich. 48197

[**] Term: **14 Years**

[21] Appl. No.: **541,353**

[22] Filed: **Jun. 21, 1990**

[52] U.S. Cl. **D12/181**

[58] Field of Search **D12/181; D26/34; 296/180.1, 180.2**

[56] References Cited

U.S. PATENT DOCUMENTS

D. 204,932	5/1966	Bott	D12/181
D. 290,454	6/1987	Menkine et al.	D12/181
3,656,423	4/1972	Anthony	D12/181

OTHER PUBLICATIONS

J. C. Whitney Catalog No. 515J, p. 67, rear air deflector with third brake light, bottom center of page.

Primary Examiner—James M. Gandy

[57] CLAIM

The ornamental design for a spoiler for a truck cap, as shown and described.

DESCRIPTION

FIG. 1 is a perspective view of a spoiler for a truck cap showing my new design it being understood that the broken lines are for illustrative purposes only and form no part of the claimed design;

FIG. 2 is an enlarged front elevation view thereof;

FIG. 3 is an enlarged top plan view thereof;

FIG. 4 is an enlarged rear elevation view thereof; and,

FIG. 5 is an enlarged end elevation view thereof.

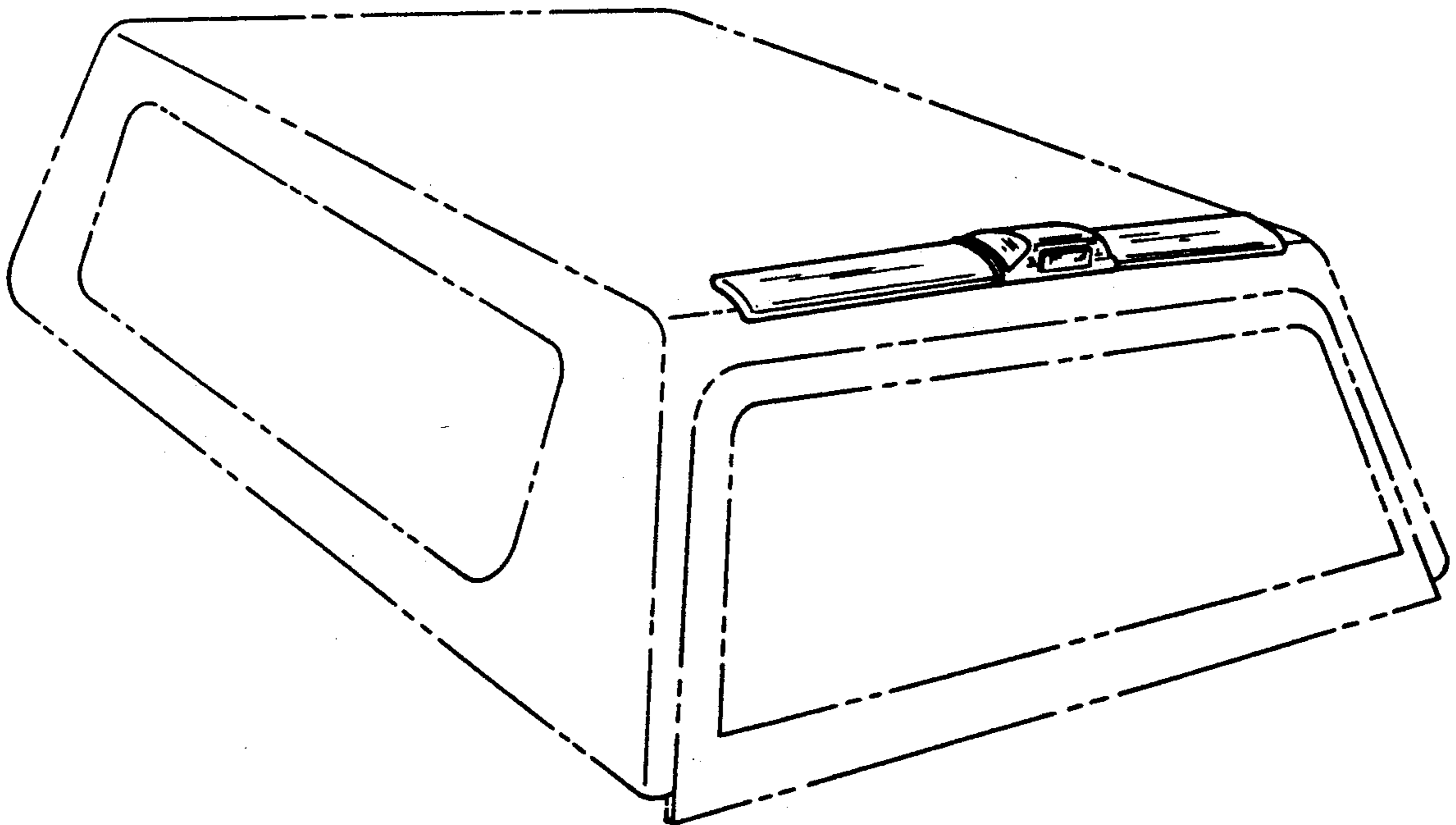

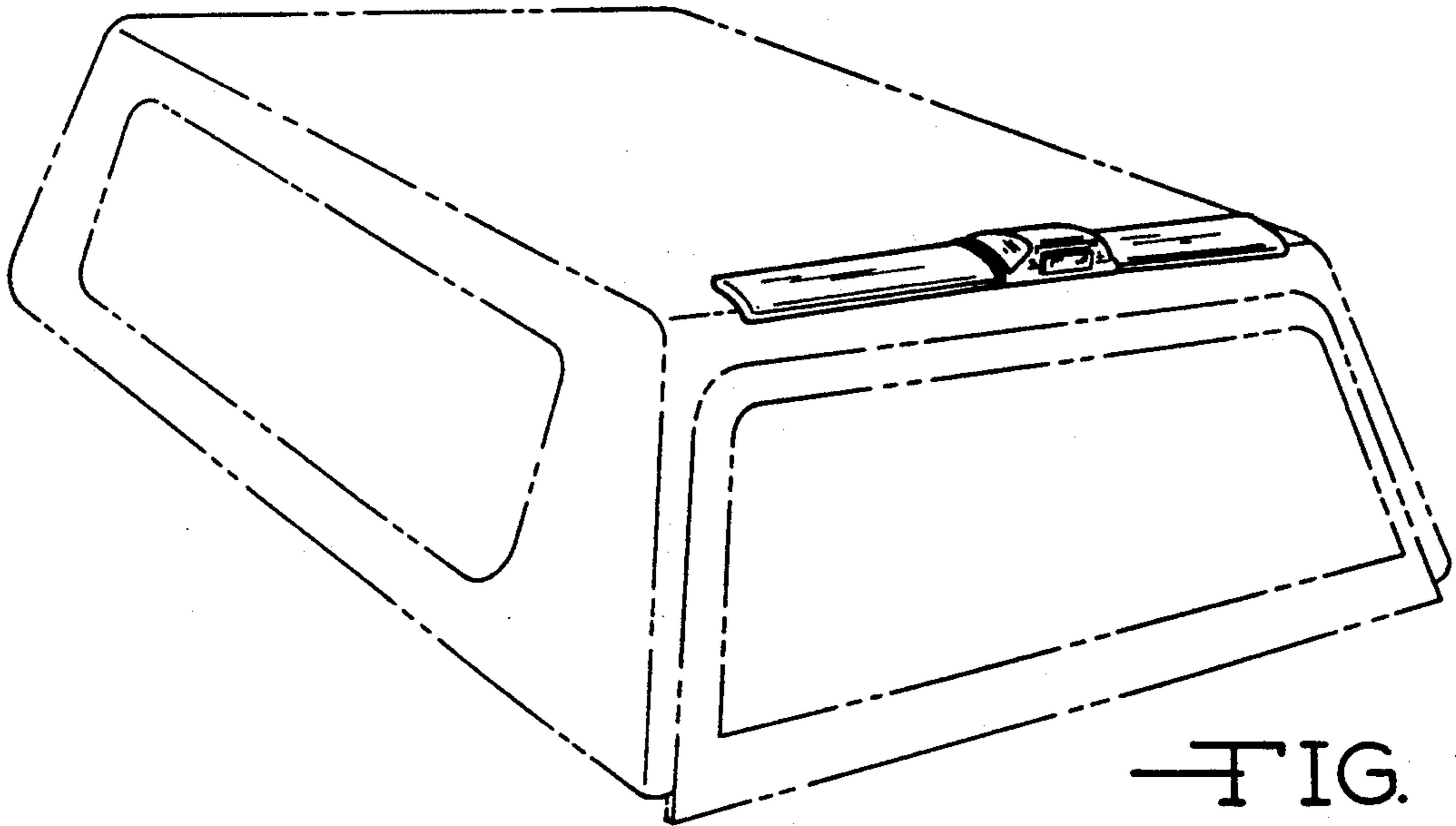

—FIG. 1



—FIG. 2

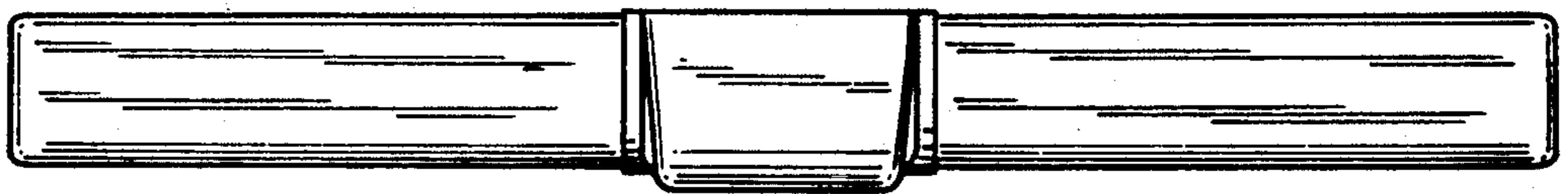

—FIG. 3

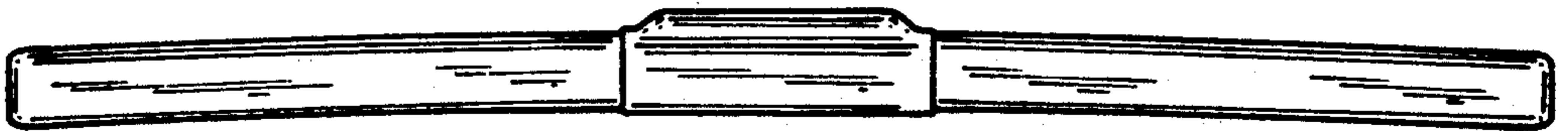

—FIG. 4



—FIG. 5