



US00D325994S

United States Patent [19]

[11] Patent Number: **Des. 325,994**

Hume et al.

[45] Date of Patent: **** May 5, 1992**

[54] LAMP

[56]

References Cited

[75] Inventors: **Roger A. Hume; Richard A. Felstead,**
both of Melton Mowbray; **Luciano**
Zucchi, London, all of England

U.S. PATENT DOCUMENTS

D. 253,195	10/1979	Henkel et al.	D26/2
4,021,659	5/1977	Wiley	362/297
4,316,241	2/1982	Gulliksen	362/361 X
4,914,342	4/1990	Mujahid et al.	313/113

[73] Assignee: **Thorn Lighting Limited,**
Borehamwood, England

Primary Examiner—Susan J. Lucas
Attorney, Agent, or Firm—Fleit, Jacobson, Cohn, Price,
Holman & Stern

[**] Term: **14 Years**

[57] CLAIM

[21] Appl. No.: **607,076**

The ornamental design for a lamp, as shown and described.

[22] Filed: **Oct. 31, 1990**

DESCRIPTION

[30] Foreign Application Priority Data

May 1, 1990 [GB] United Kingdom D2006506

[52] U.S. Cl. **D26/2**

[58] Field of Search D26/2, 3, 24; 362/326,
362/334, 335, 337, 340, 361, 297, 304, 305, 309,
311, 341, 346, 347, 349; 313/113, 315, 493, 318

FIG. 1 is a front elevational view of a lamp showing our new design;

FIG. 2 is a rear elevational view thereof;

FIG. 3 is a side elevational view thereof;

FIG. 4 is an opposite side elevational view thereof;

FIG. 5 is a top plan view thereof; and,

FIG. 6 is a bottom plan view thereof.

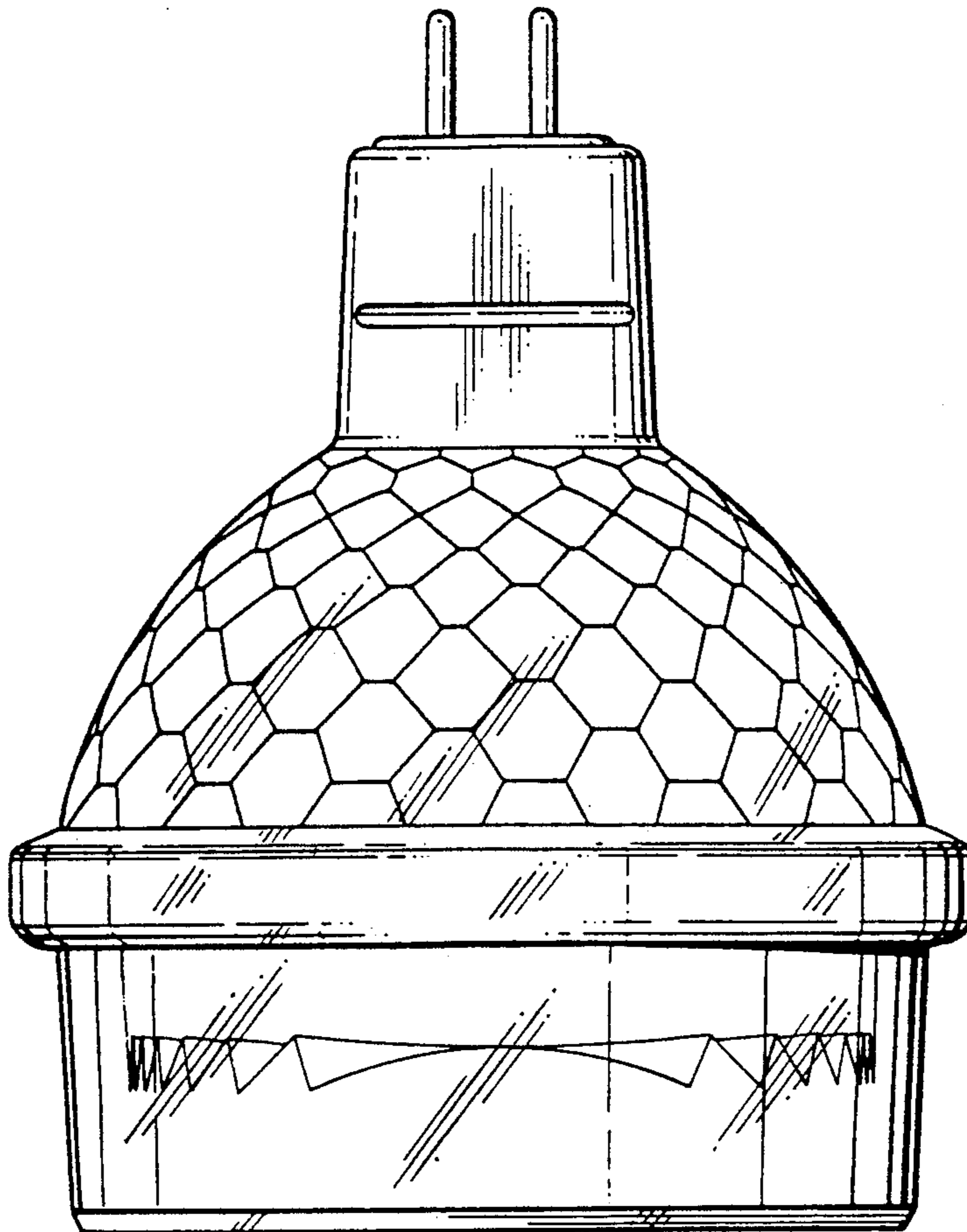

Fig. 1.

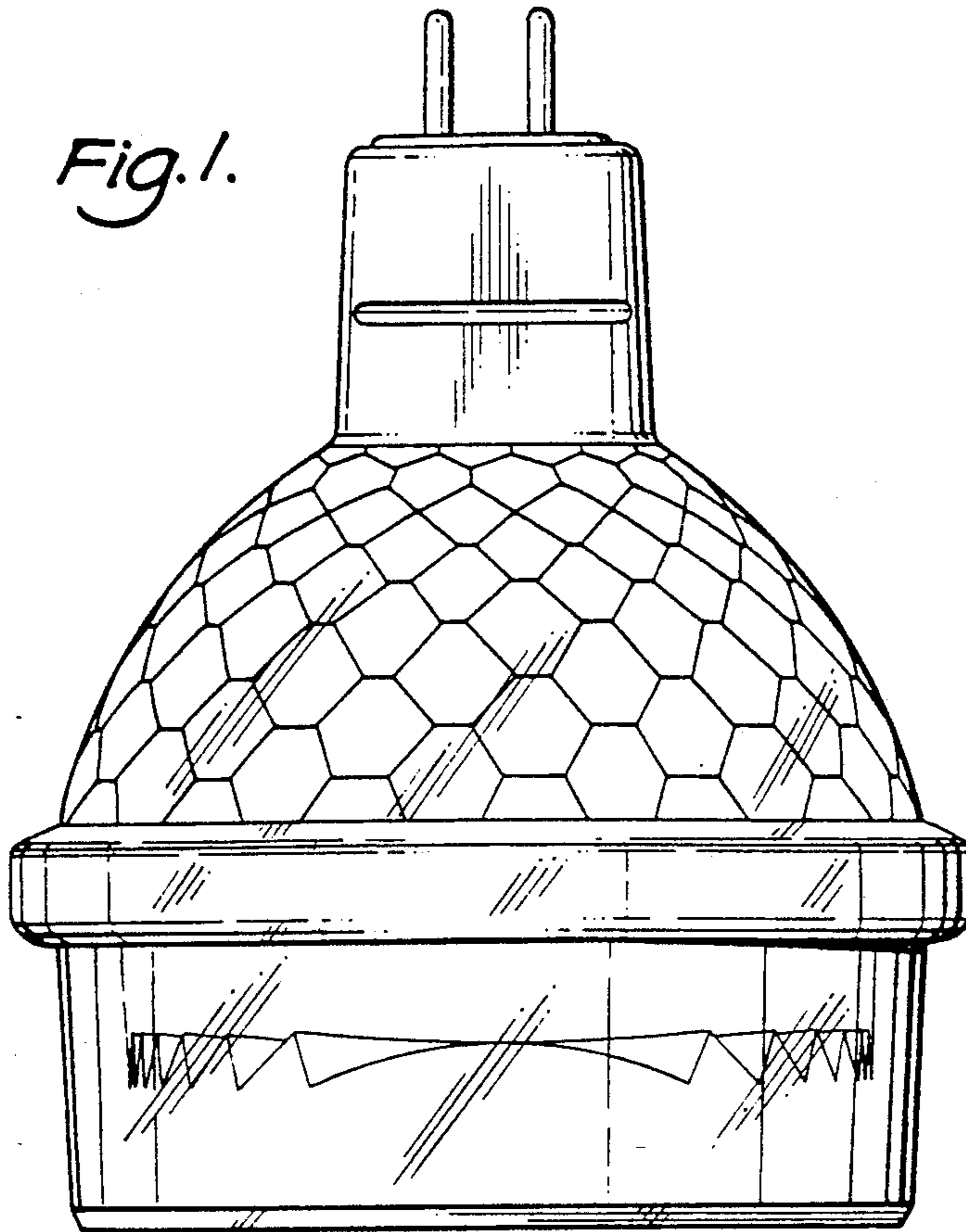
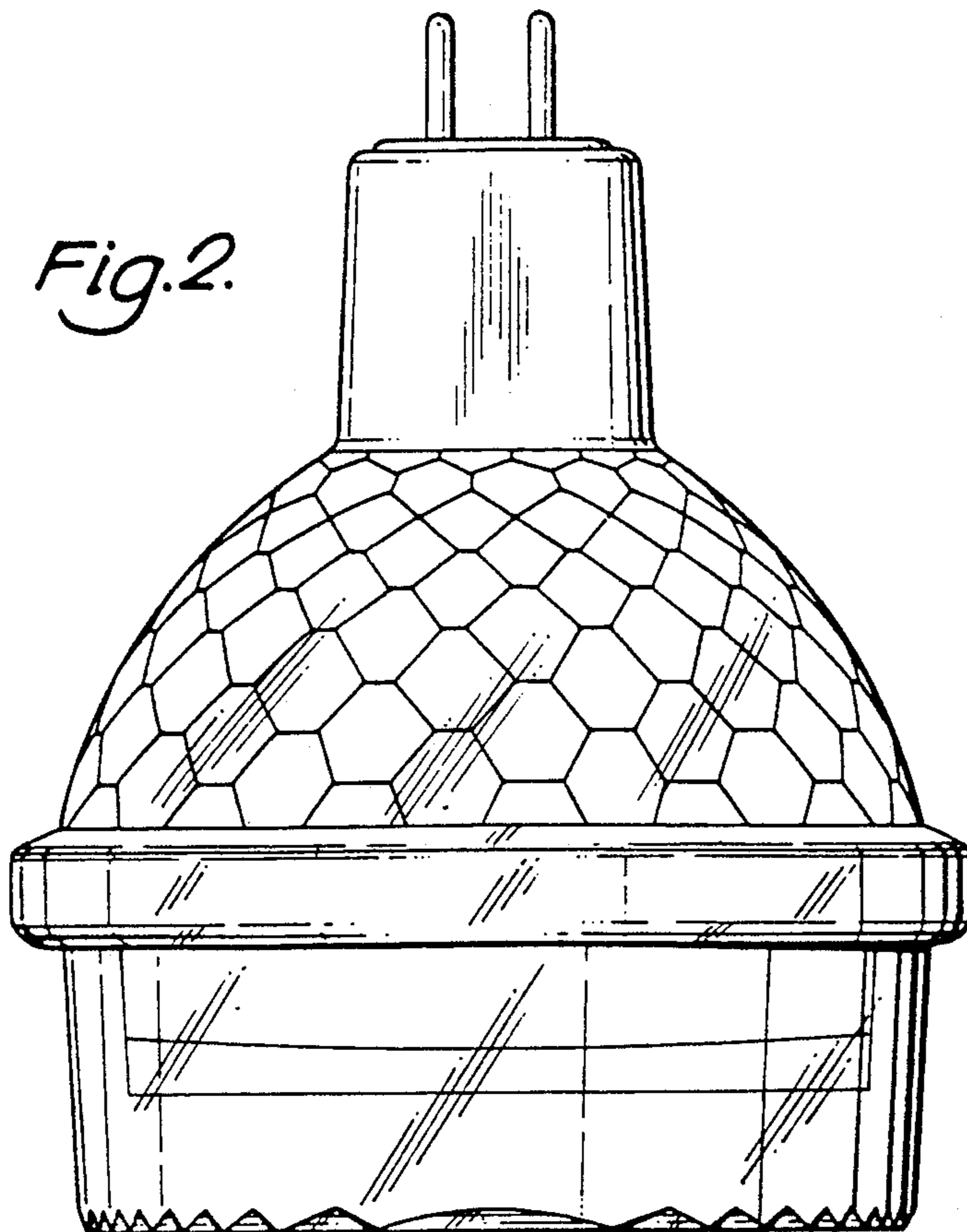

Fig. 2.



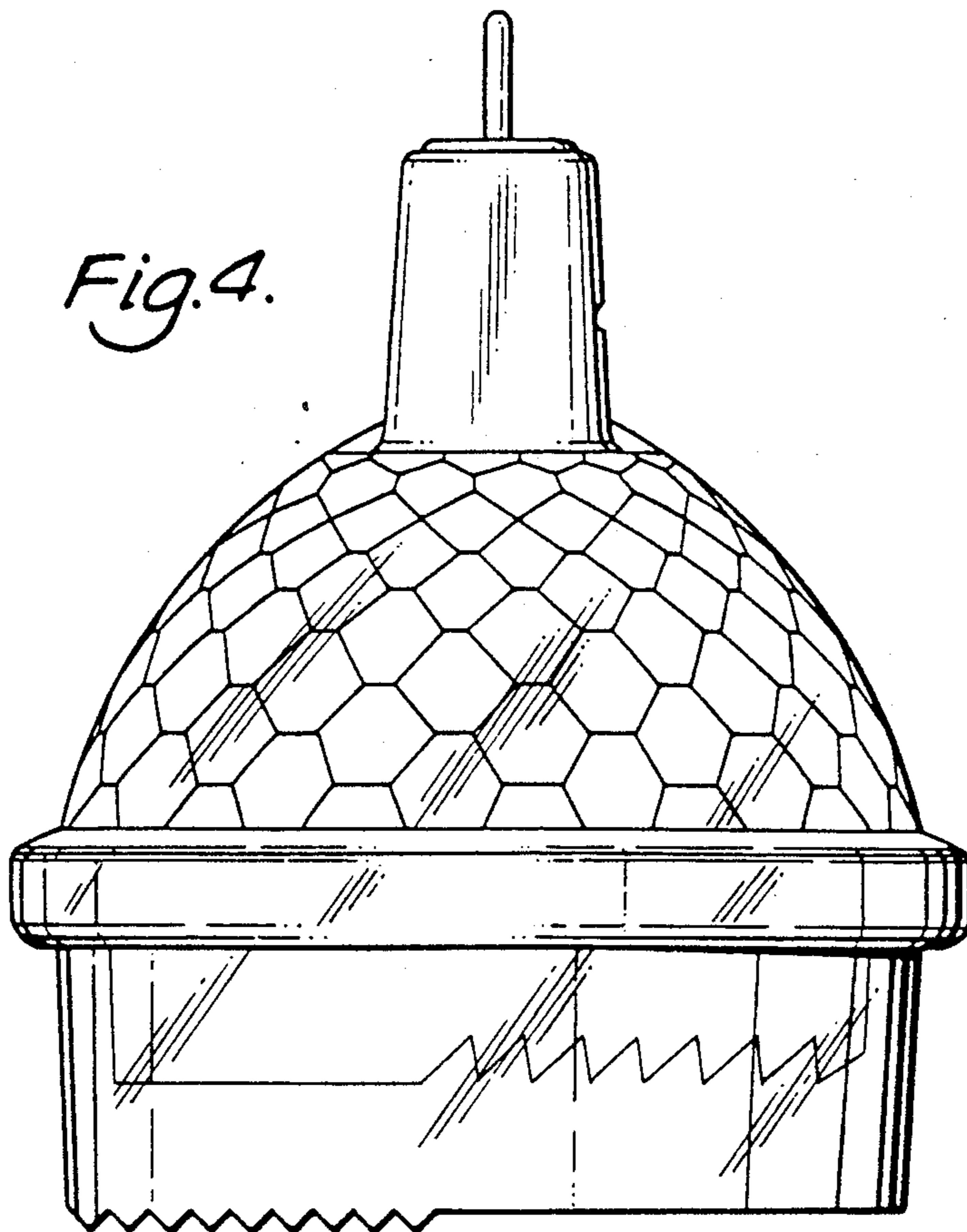
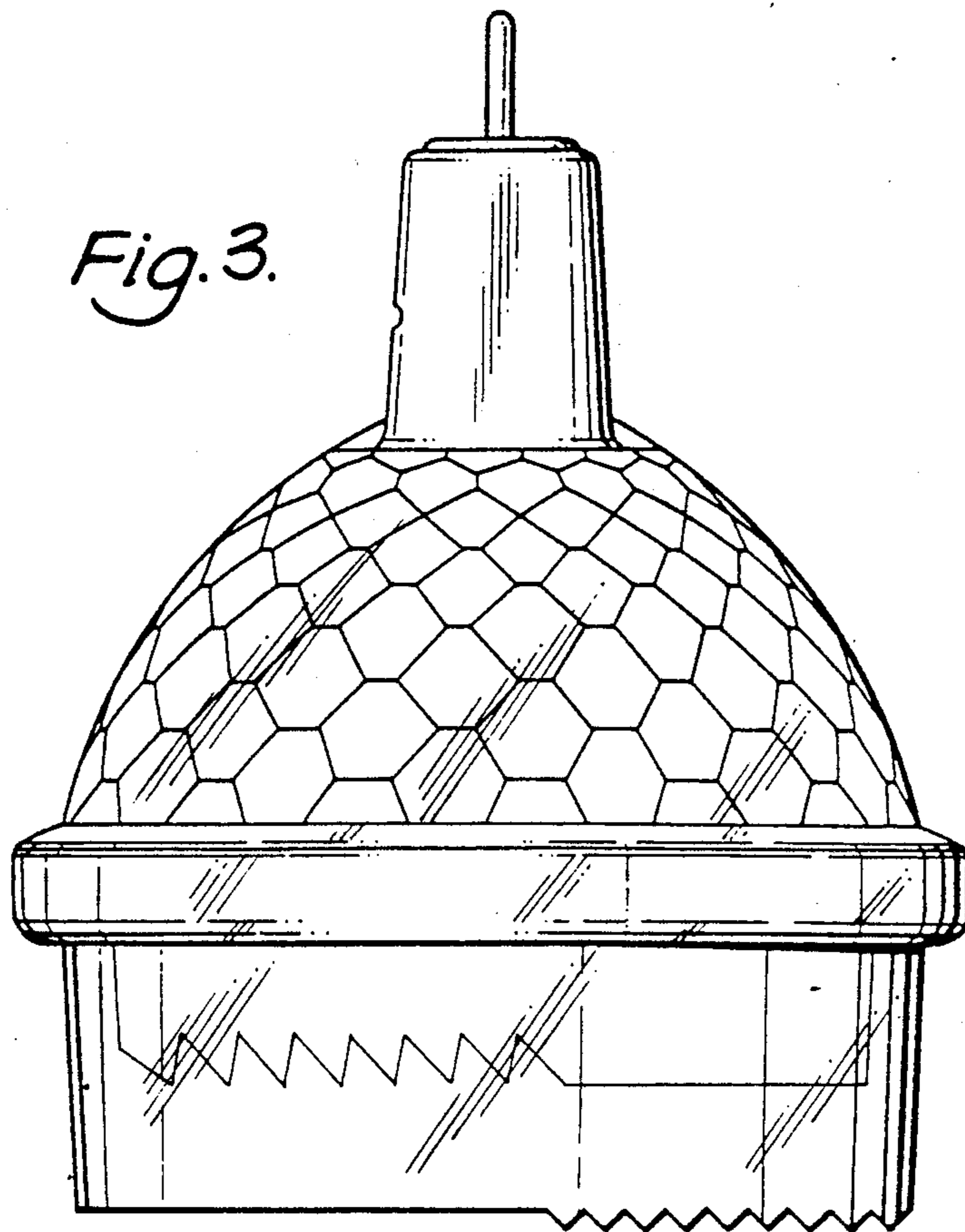

Fig. 5.

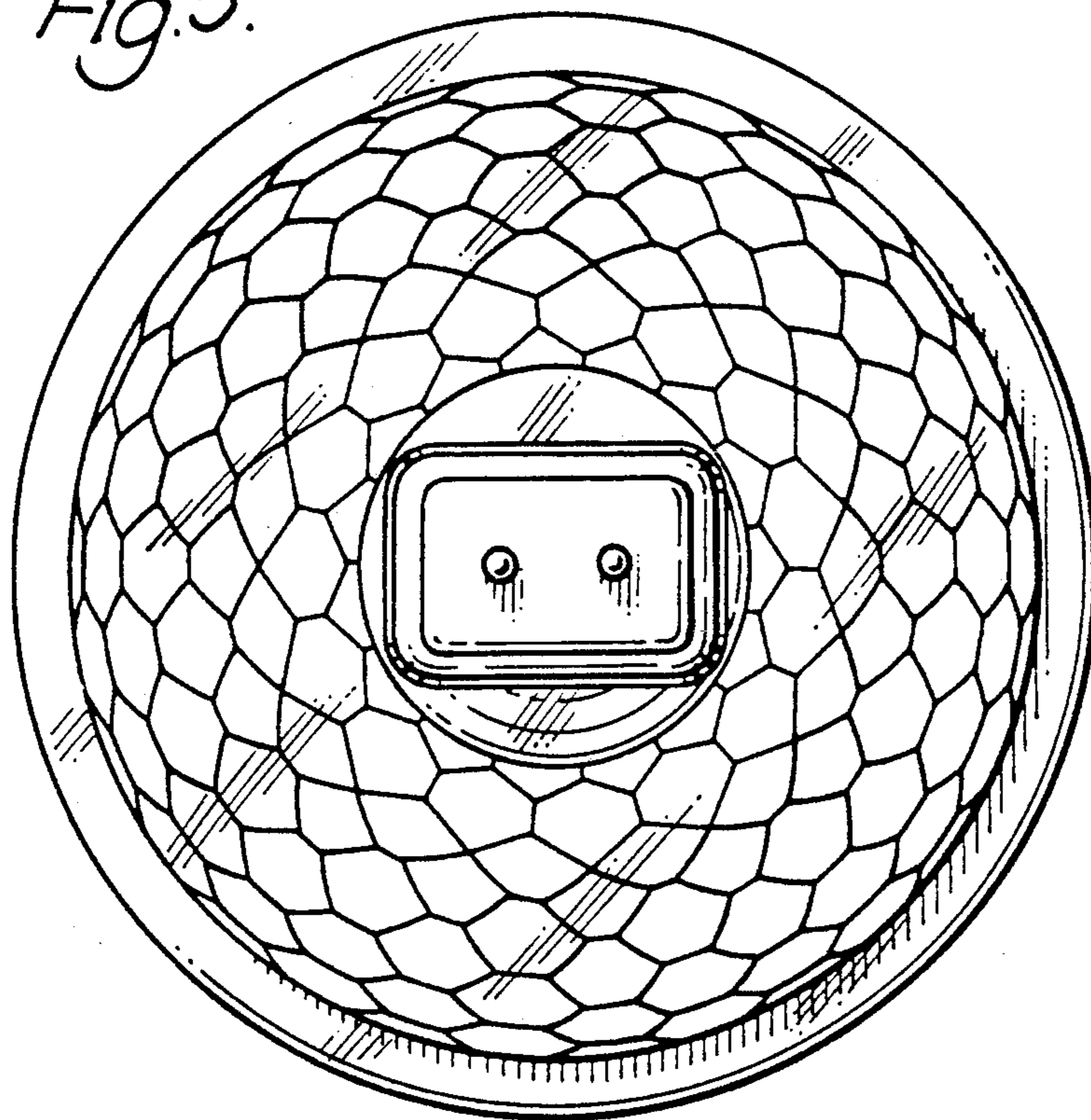

Fig. 6.

