



US00D325923S

United States Patent [19]

Boyer et al.

[11] Patent Number: Des. 325,923

[45] Date of Patent: ** May 5, 1992

[54] DEVELOPER SOLUTION CARTRIDGE

[75] Inventors: Jon F. Boyer, Earleville, Md.; Lee C. Fisher, Rochester, N.Y.; Douglas J. Hohlbein, Central Islip, N.Y.; Anthony P. Montalbano, Bayville, N.Y.; Christopher P. Montalbano, Great Neck, N.Y.; John G. Van Remoortel, Newark, Del.; Joel L. Vanover, Elkton, Md.

[73] Assignee: E. I. Du Pont de Nemours and Company, Wilmington, Del.

[*] Notice: The portion of the term of this patent subsequent to Apr. 21, 2006 has been disclaimed.

[**] Term: 14 Years

[21] Appl. No.: 421,412

[22] Filed: Oct. 13, 1989

[52] U.S. Cl. D16/250

[58] Field of Search D16/246, 250; D18/43; 355/200, 245, 260; 206/316, 446, 461, 474, 495, 532, 401, 628, 631; 222/166, 375, DIG. 1

[56] References Cited

U.S. PATENT DOCUMENTS

D. 218,152	7/1970	Emerson	D18/43
D. 248,277	6/1978	Hartman et al.	D18/43
D. 267,013	11/1982	Hipp, Jr.	D18/43
D. 267,097	11/1982	Tacklind et al.	D18/43
D. 271,113	10/1983	Birkeland et al.	D18/43
D. 298,257	10/1988	Masaki	D18/43
D. 310,844	9/1990	Ohata	D18/43
4,533,225	8/1985	Shiga	354/322
4,629,303	12/1986	Vermarien	354/320
4,641,940	2/1987	Müller et al.	354/322
4,734,728	3/1988	Müller	354/324
4,806,962	2/1989	Uchida et al.	354/324
4,814,809	3/1989	De Prijcker et al.	354/319

Primary Examiner—Bernard Ansher
Assistant Examiner—Dominic Simone
Attorney, Agent, or Firm—John E. Griffiths

[57] CLAIM

The ornamental design for a developer solution cartridge, as shown and described.

DESCRIPTION

FIG. 1 is a top plan view of a developer solution cartridge showing our new design;
FIG. 2 is a bottom plan view thereof;
FIG. 3 is a right side elevational view thereof;
FIG. 4 is a left side elevational view thereof;
FIG. 5 is a front elevational view thereof; and,
FIG. 6 is a rear elevational view thereof.

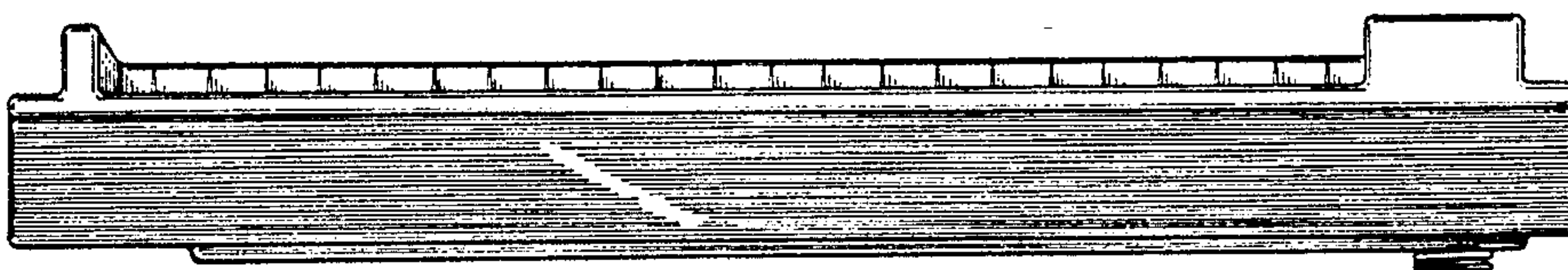
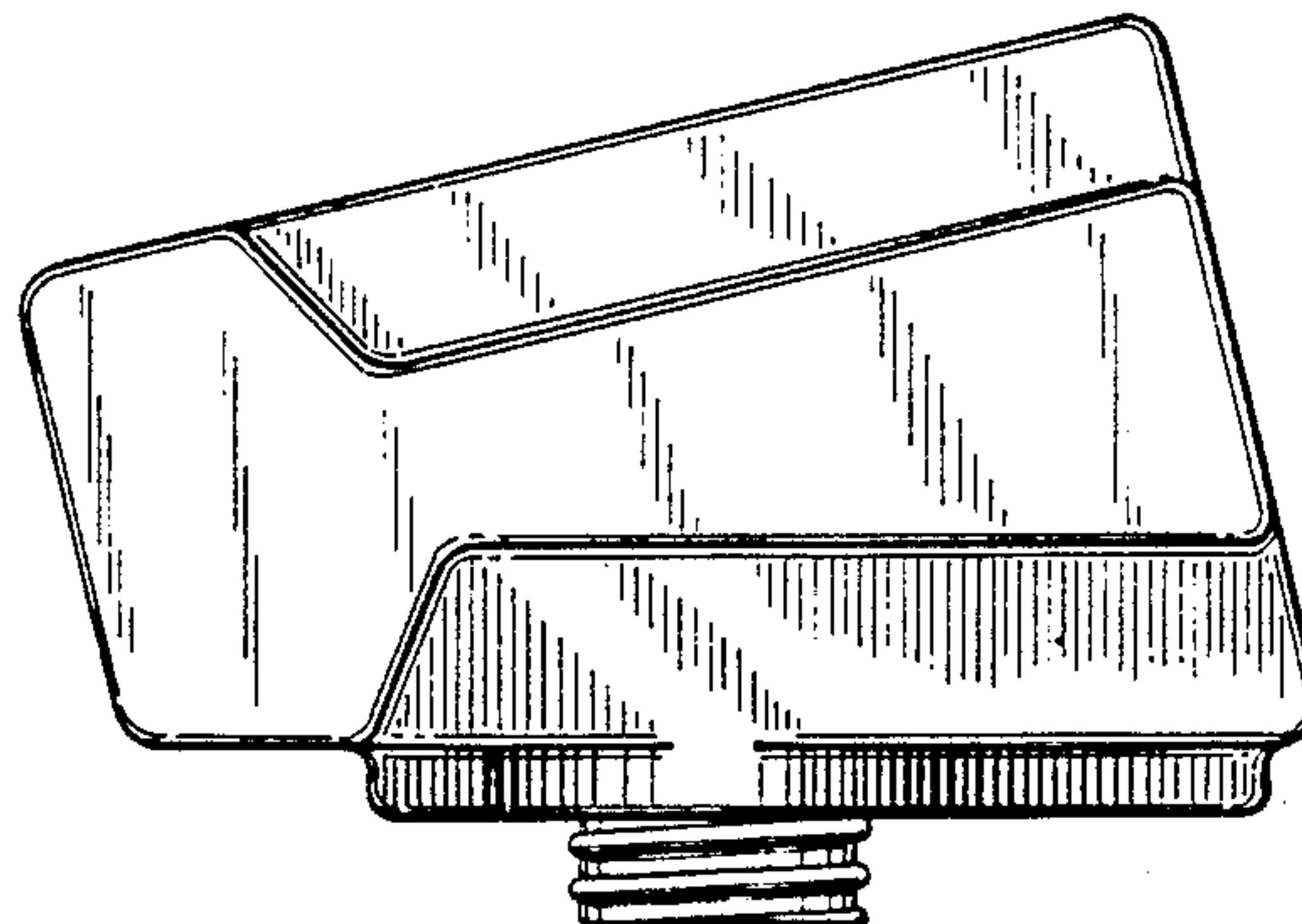
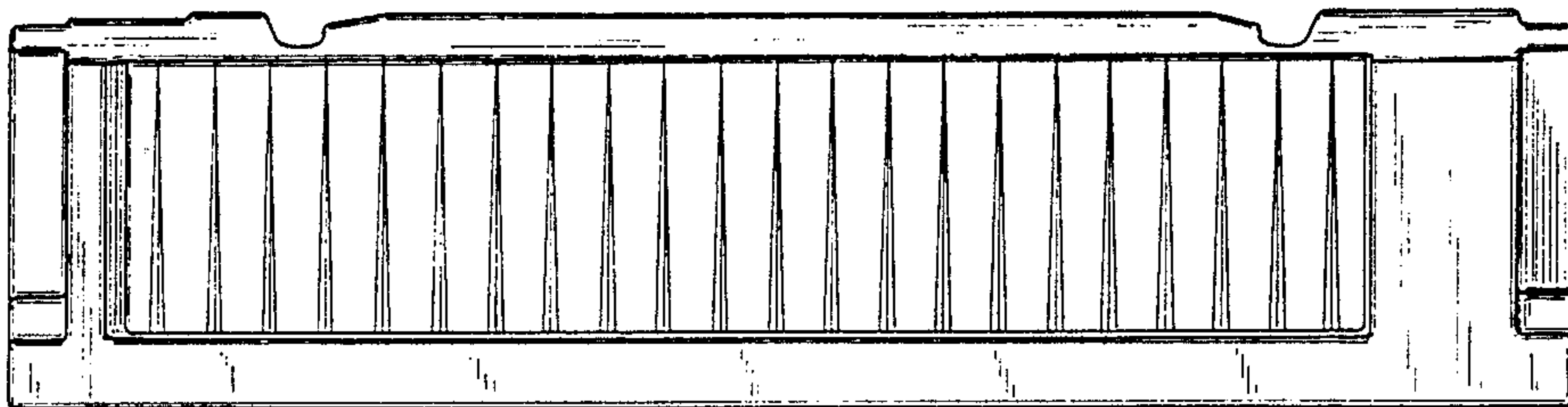

Fig. 1

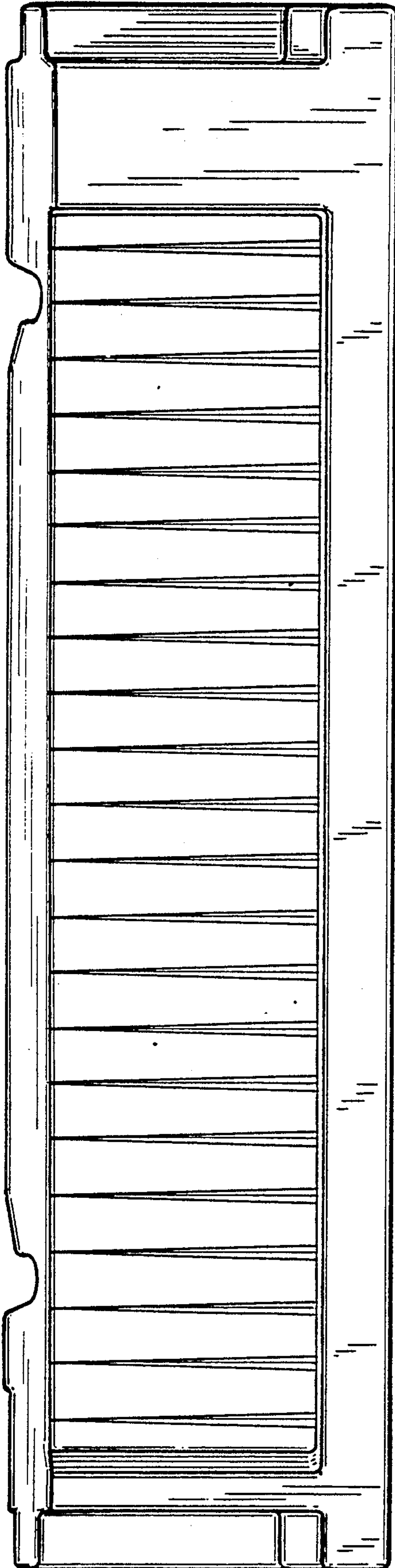

Fig. 2

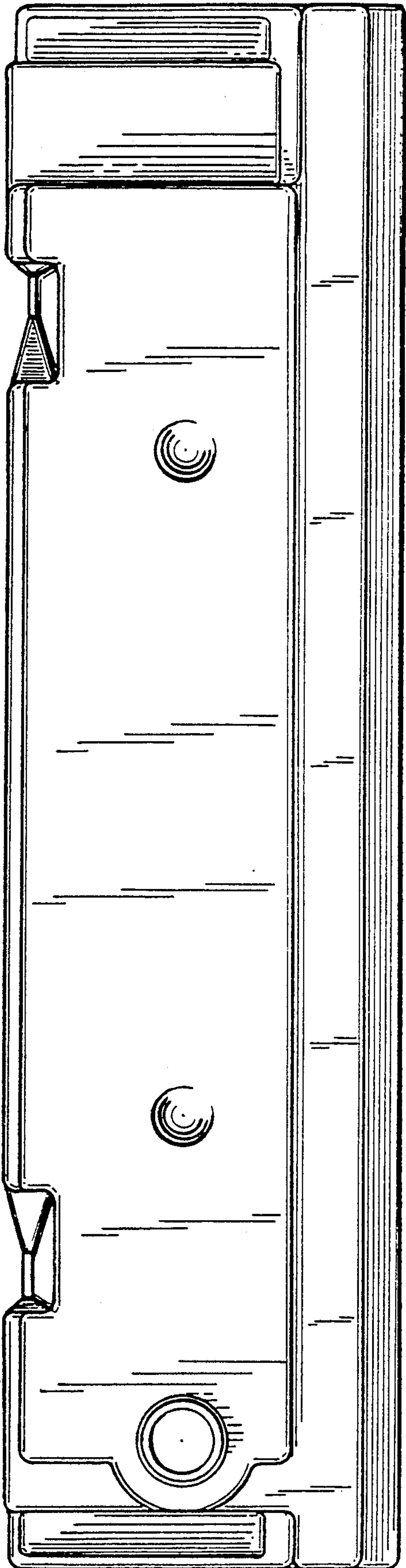

Fig. 3

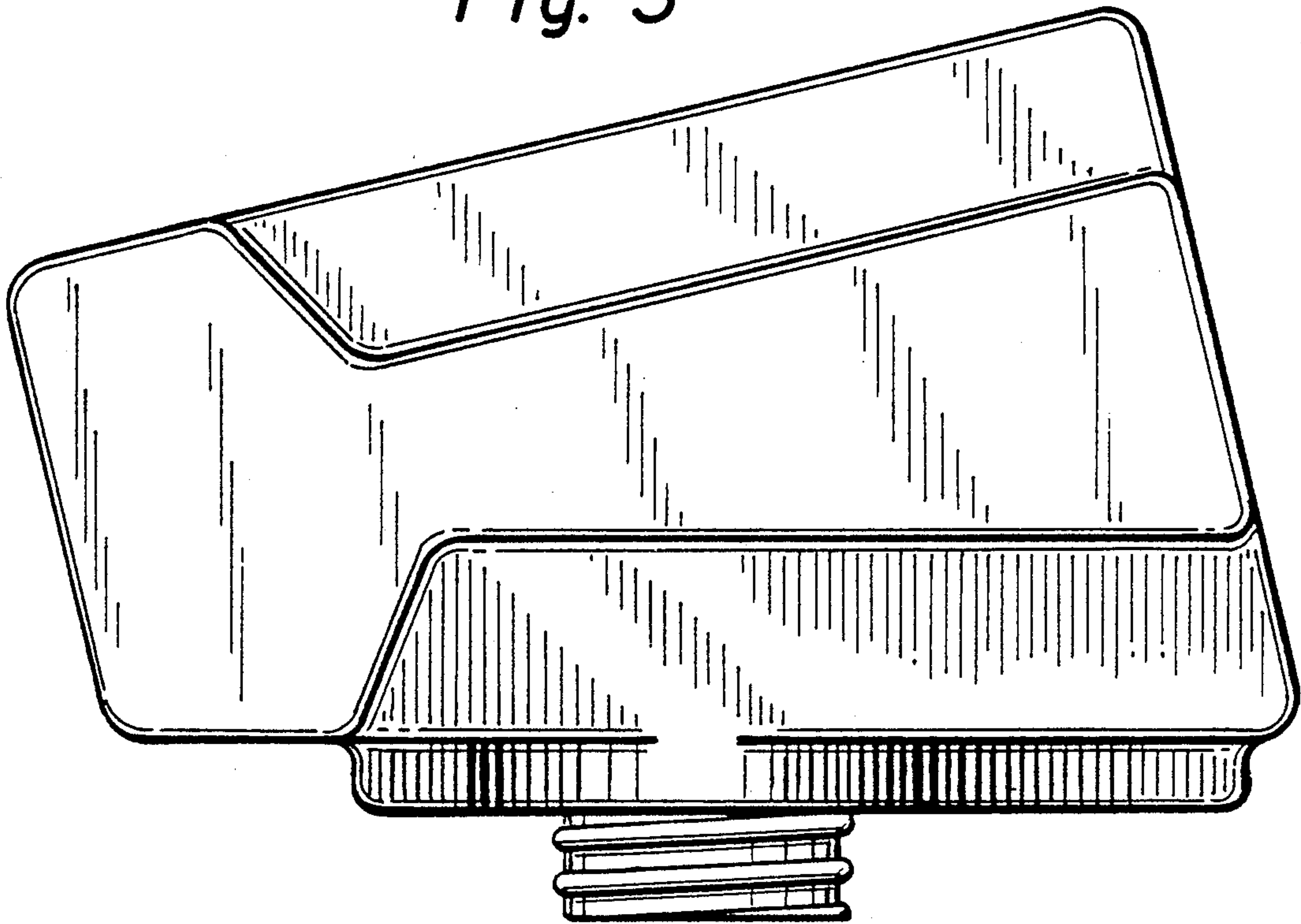

Fig. 4

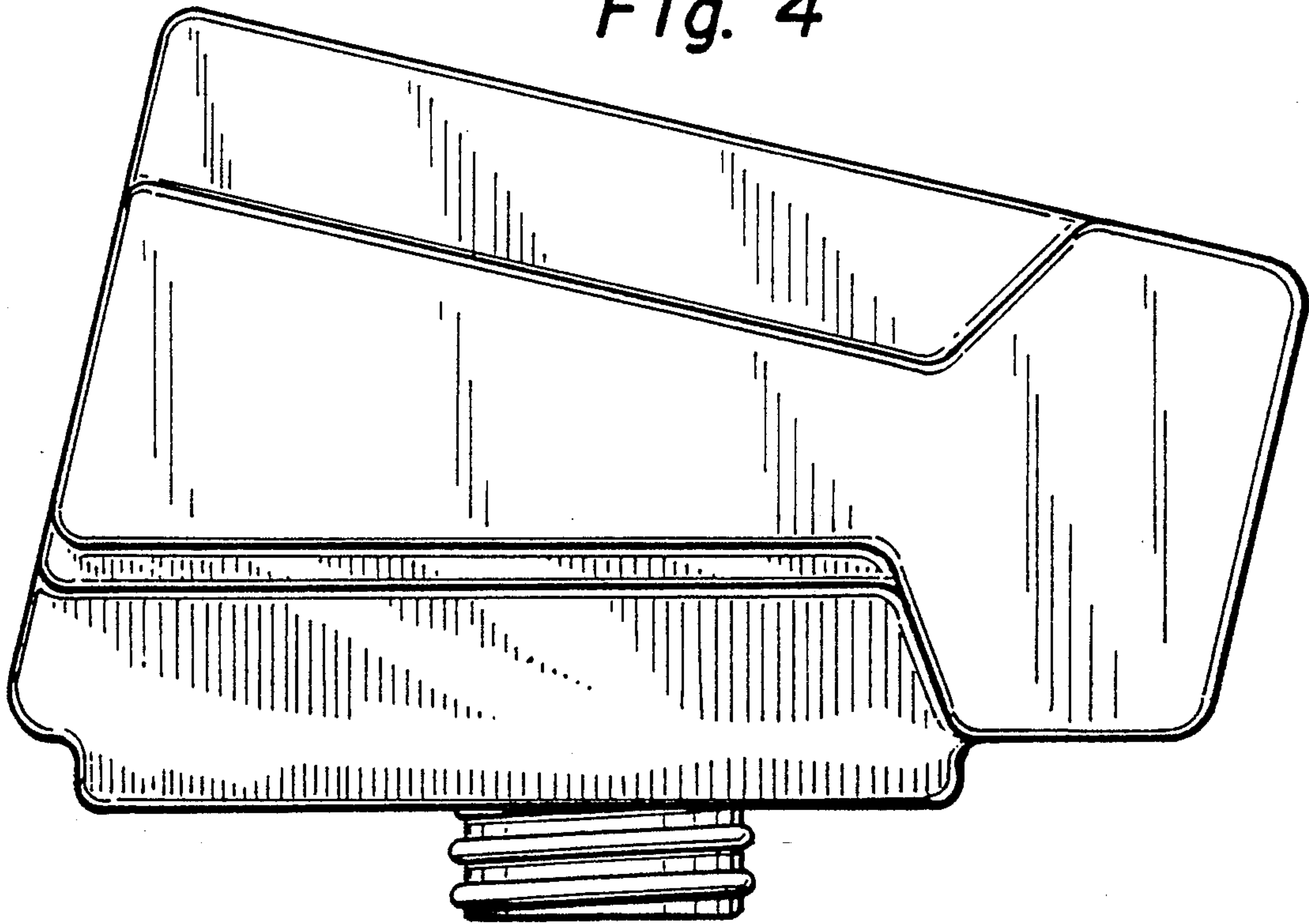

Fig. 5

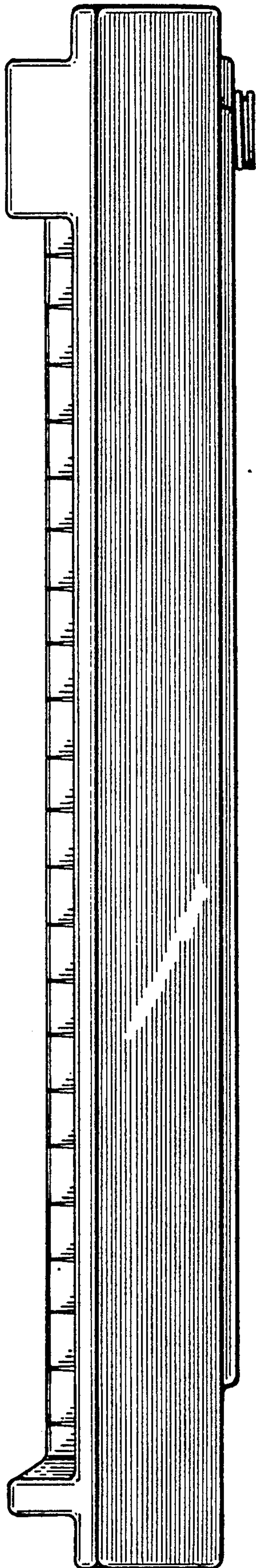

Fig. 6

