



US00D325892S

United States Patent [19]

[11] Patent Number: Des. 325,892

Nesterick et al.

[45] Date of Patent: ** May 5, 1992

[54] ELECTRICALLY POWERED THREE WHEELED VEHICLE

[75] Inventors: Elaine M. Nesterick, Ventura; Robert W. Reynolds, Camarillo; Spencer L. MacKay, Agoura Hills; Cleve A. Graham, Simi Valley, all of Calif.

[73] Assignee: Everest & Jennings, Inc., Camarillo, Calif.

[**] Term: 14 Years

[21] Appl. No.: 416,123

[22] Filed: Oct. 2, 1989

[52] U.S. Cl. D12/85; D12/131

[58] Field of Search D12/85, 131; 180/211, 180/215, 216, 907, 65.1

[56] References Cited

U.S. PATENT DOCUMENTS

D. 241,929	10/1976	Cosper	D12/85
D. 285,671	9/1986	Thieme et al.	D12/85
D. 303,101	8/1989	Shepard et al.	D12/85
3,580,349	5/1971	Brennan et al.	180/27
4,452,327	6/1984	Mowat et al.	180/11
4,570,739	2/1986	Kramer	180/216
4,666,008	5/1987	Shepard et al.	180/16
4,729,447	3/1988	Morse	180/65.1
4,776,416	10/1988	Morse	180/216

FOREIGN PATENT DOCUMENTS

3128112A1	3/1983	Fed. Rep. of Germany	180/907
-----------	--------	----------------------------	---------

OTHER PUBLICATIONS

Scout by Burke Inc. Flyer. 3-wheel vehicle.
Title: Pacer TM, Author: Everest & Jennings, 4 pages, ©1986.

Title: Ensore (Model 438) Ortho-Kinetics, Inc., Author: Ortho-Kinetics, Inc., Date: 1988, 2 pages.

Title: The Bravo!® Model 434 Front-Wheel Drive Electric 3-Wheeler, Author: Ortho-Kinetics, Inc., Date: 1986, 4 pages.

Title: Discover the difference Sierra TM can make in your life, Author: Ortho-Kinetics, Inc., Date: 1988, 3 pages.

Title: Fun and Independence from Electric Mobility, Author: Electric Mobility Corporation, Date: 1986, 15 pages.

Primary Examiner—James M. Gandy

Attorney, Agent, or Firm—Kelly Bauersfield & Lowry

[57] CLAIM

The ornamental design for an electrically powered three wheeled vehicle, as shown.

DESCRIPTION

FIG. 1 is a perspective view showing the front, right and top sides of an electrically powered three wheeled vehicle embodying the new design;

FIG. 2 is a left side elevational view thereof;

FIG. 3 is a front elevational view thereof;

FIG. 4 is a rear elevational view thereof;

FIG. 5 is a top plan view thereof; and,

FIG. 6 is a bottom plan view thereof.

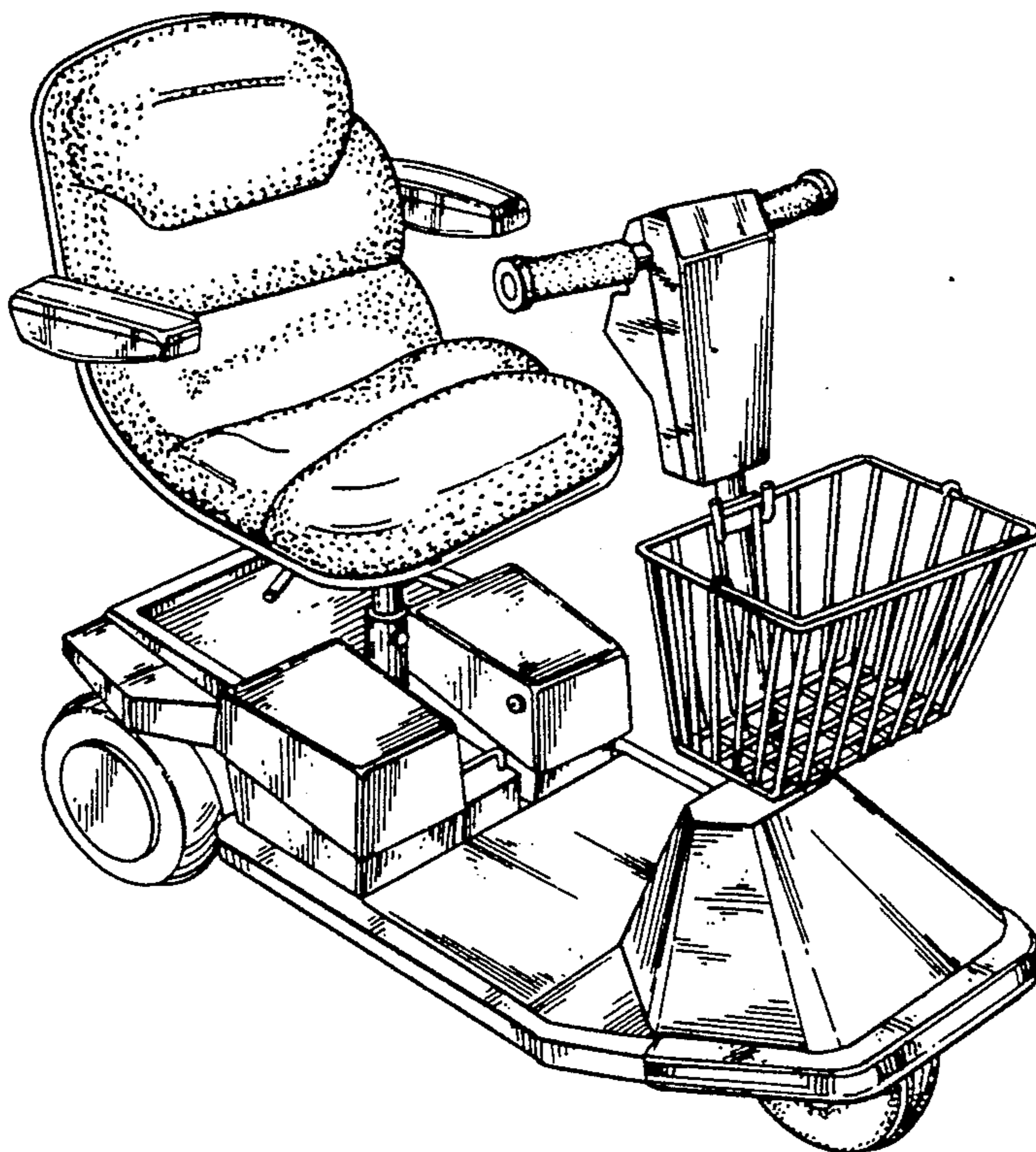

FIG. 1

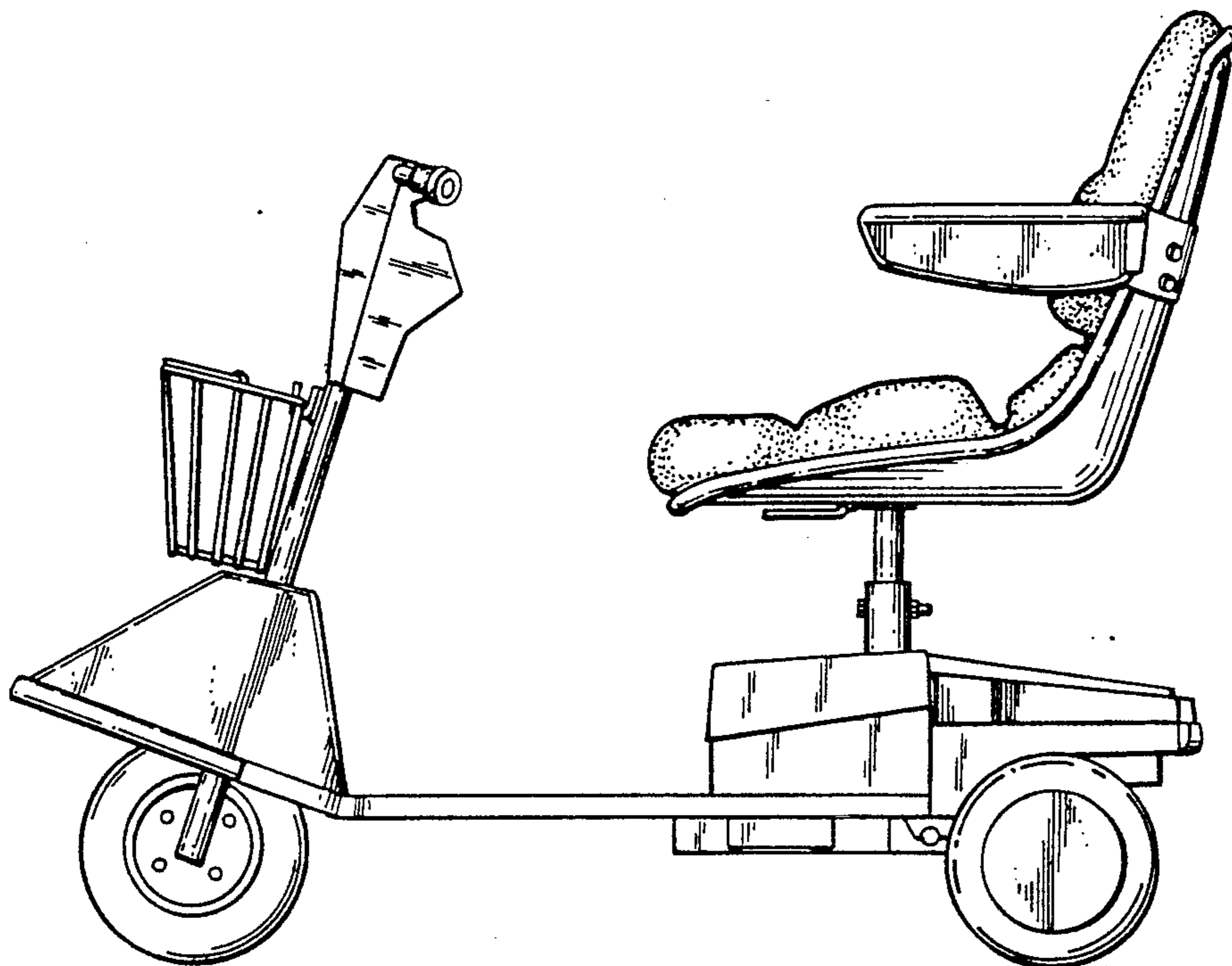
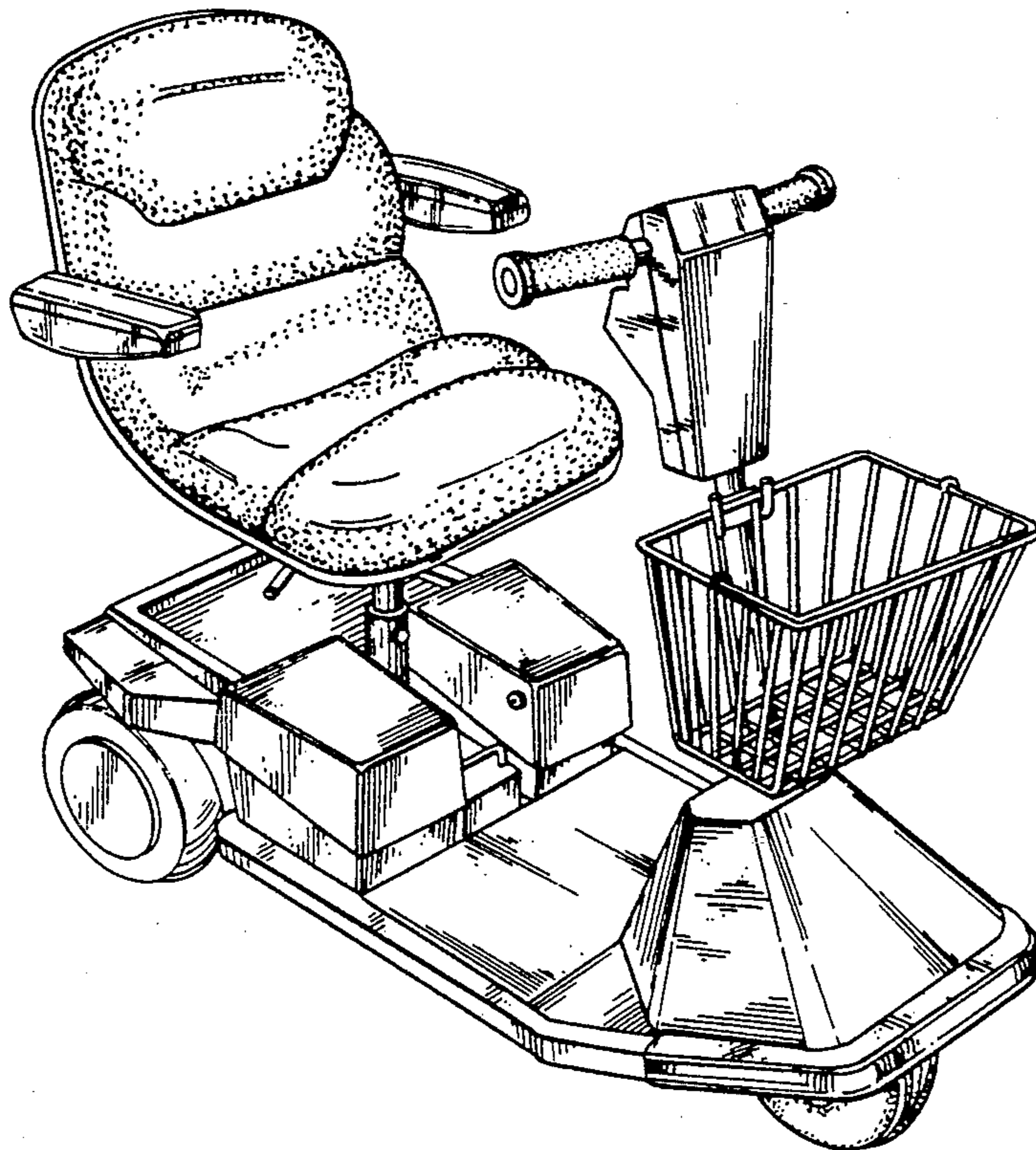

FIG. 2

FIG. 3

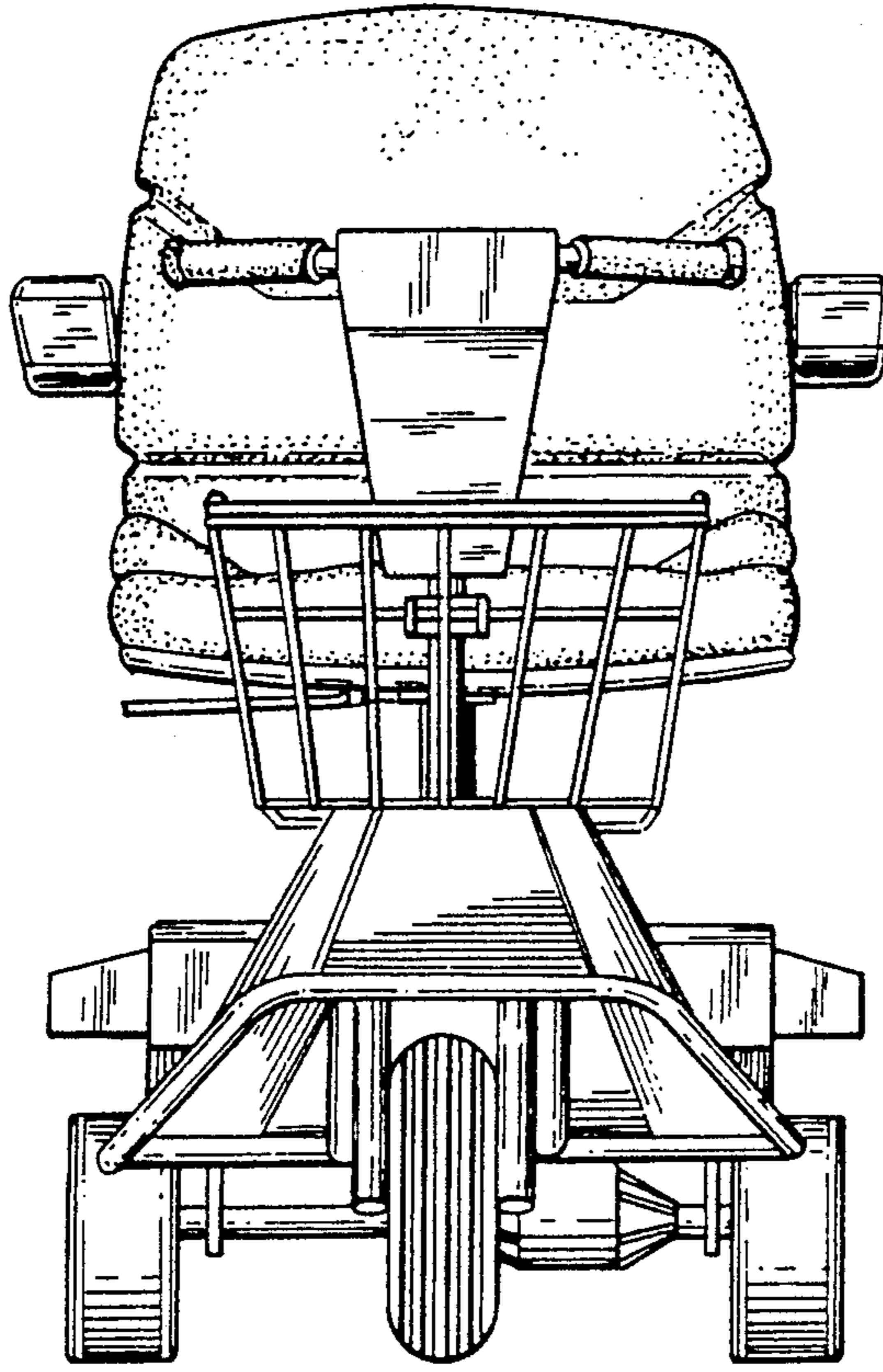
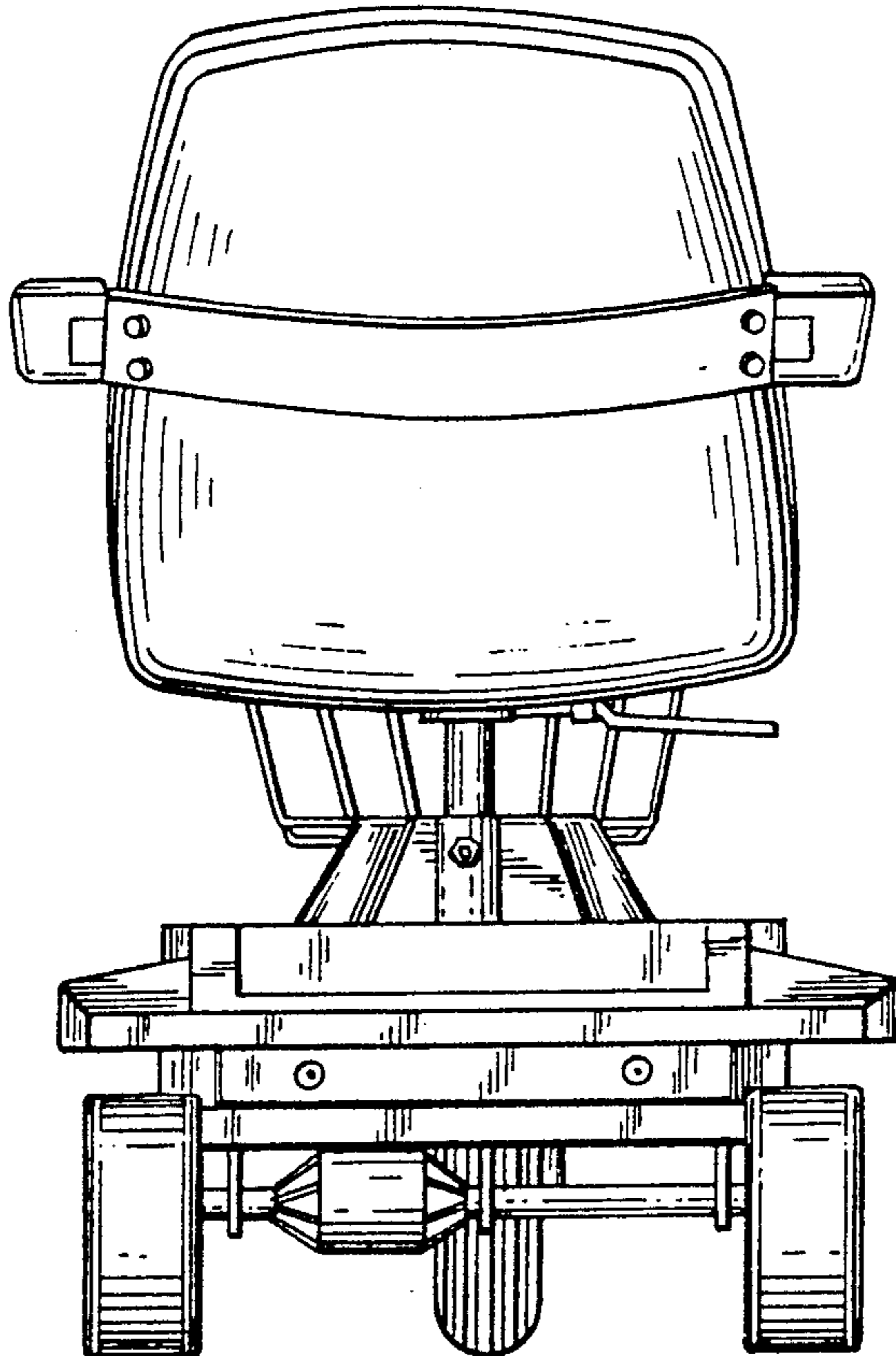

FIG. 4



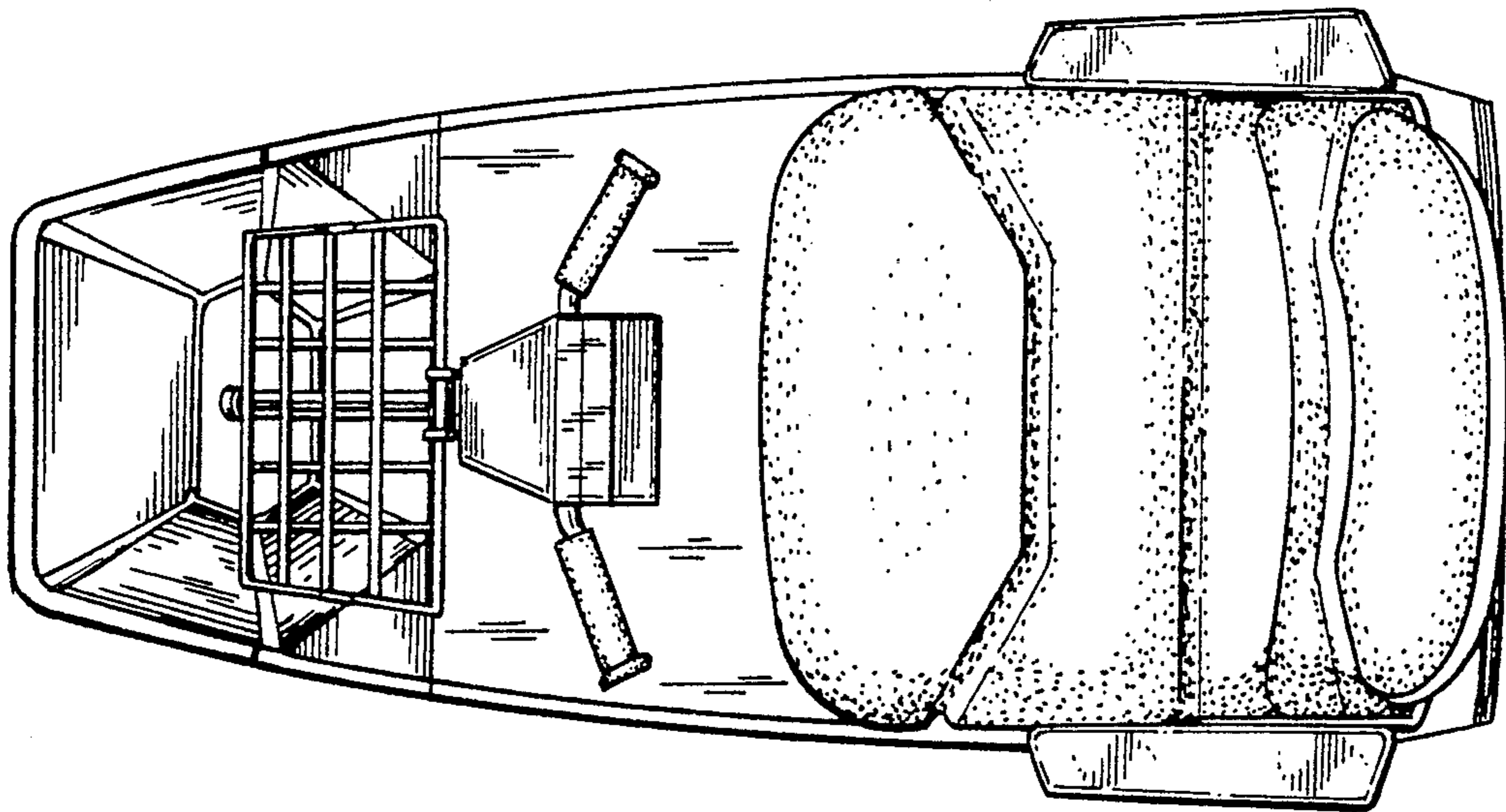

FIG. 5

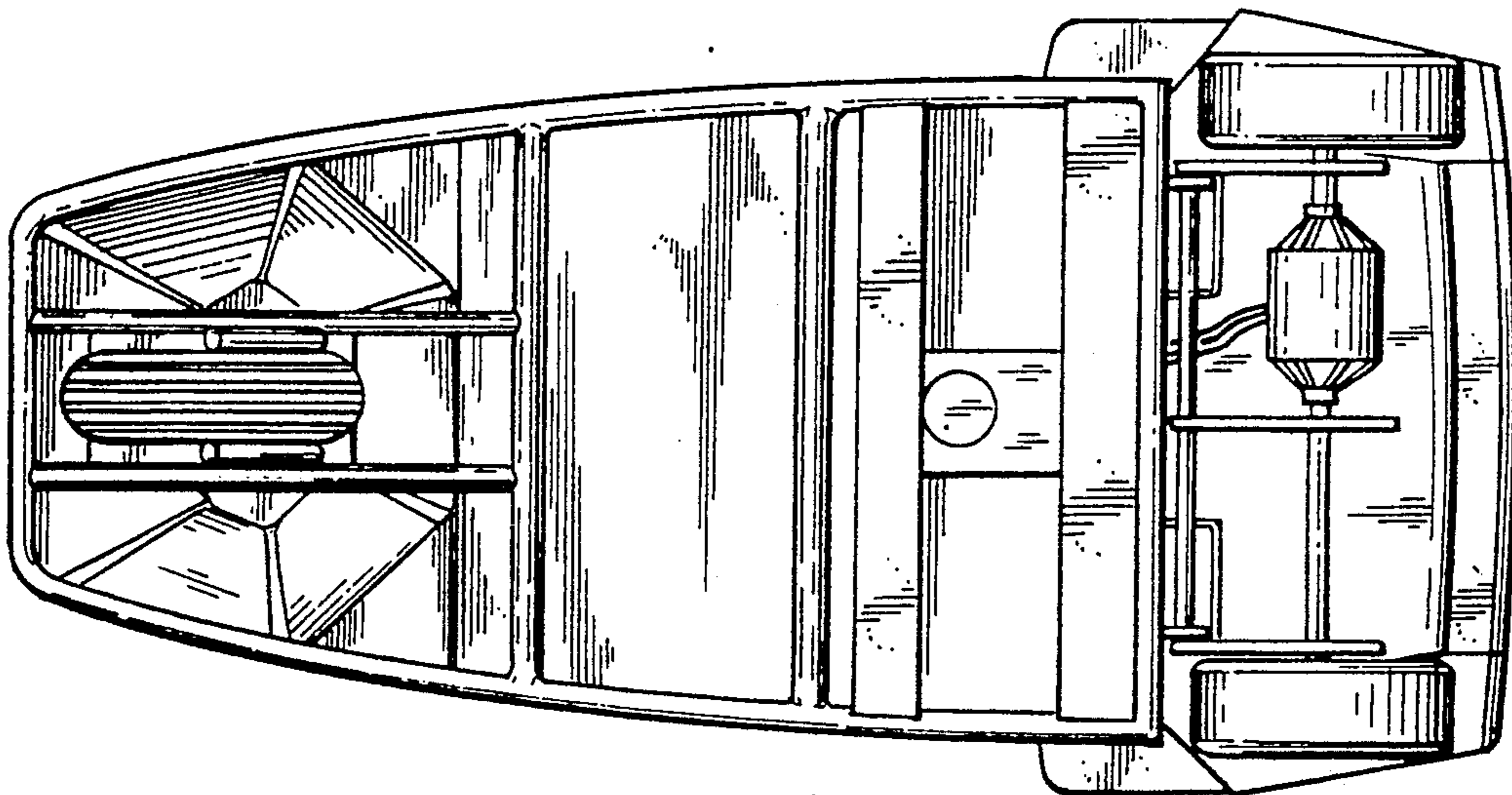

FIG. 6