



US00D325567S

United States Patent [19]

Jacoby, Jr. et al.

[11] Patent Number: Des. 325,567

[45] Date of Patent: ** Apr. 21, 1992

[54] COMBINED WALL PLATE AND DUAL LINEAR SLIDE DIMMER

[75] Inventors: Elliot G. Jacoby, Jr., Glenside; Robin C. Moseley, Allentown; Rita R. Swartvagher, Coopersburg; Thomas A. Foster, Bethlehem; Bruce D. Colgan, Wescosville; David L. Buehler, Bethlehem, all of Pa.

[73] Assignee: Lutron Electronics Co., Inc., Coopersburg, Pa.

[**] Term: 14 Years

[21] Appl. No.: 351,103

[22] Filed: May 12, 1989

[52] U.S. Cl. D13/170

[58] Field of Search D8/350-353; D13/158, 168-171; 174/66; 200/310, 332, 341; 220/241; 323/905

[56] References Cited

U.S. PATENT DOCUMENTS

- D. 311,371 10/1990 Jacoby D13/171
- D. 311,678 10/1990 Graef et al. D13/171
- D. 314,184 1/1991 Mongeau D13/170
- 4,563,592 1/1986 Yuhasz et al. 323/905
- 4,783,581 11/1988 Flowers et al. D13/170

FOREIGN PATENT DOCUMENTS

1048798 2/1988 United Kingdom .

OTHER PUBLICATIONS

Lutron Electronics Brochure—Nova T* Thin-Profile Controls Selection Guide—dated Jul. 1989.

Lutron Electronics Brochure—Nova®—dated Jun. 1988.

Primary Examiner—Bernard Ansher

Assistant Examiner—Sandra Morris
Attorney, Agent, or Firm—Seidel, Gonda, Lavorgna & Monaco

[57] CLAIM

The ornamental design for a combined wall plate and dual linear slide dimmer, as shown and described.

DESCRIPTION

FIG. 1 is a front elevational view of a combined wall plate and dual linear slide dimmer, showing our new design;

FIG. 2 is a right side perspective view thereof, the left side being a mirror image;

FIG. 3 is a bottom elevational view thereof, the top being a mirror image;

FIG. 4 is an isometric view thereof;

FIG. 5 is a front elevational view of a second embodiment of FIG. 1;

FIG. 6 is a front elevational view of a third embodiment of FIG. 1;

FIG. 7 is a right side elevational view of FIG. 6, the left side being a mirror image;

FIG. 8 is a bottom elevational view of FIG. 6, the top being a mirror image;

FIG. 9 is an isometric view of FIG. 6;

FIG. 10 is a front elevational view of a fourth embodiment of FIG. 1;

FIG. 11 is a front elevational view of a fifth embodiment of FIG. 1;

FIG. 12 is a right side elevational view of FIG. 11, the left side being a mirror image;

FIG. 13 is a bottom elevational view of FIG. 11 the top being a mirror image;

FIG. 14 is an isometric view of FIG. 11; and,

FIG. 15 is a front elevational view of a sixth embodiment of FIG. 1.

The broken line showing of a switch is for illustrative purposes only, and forms no part of the claimed design.

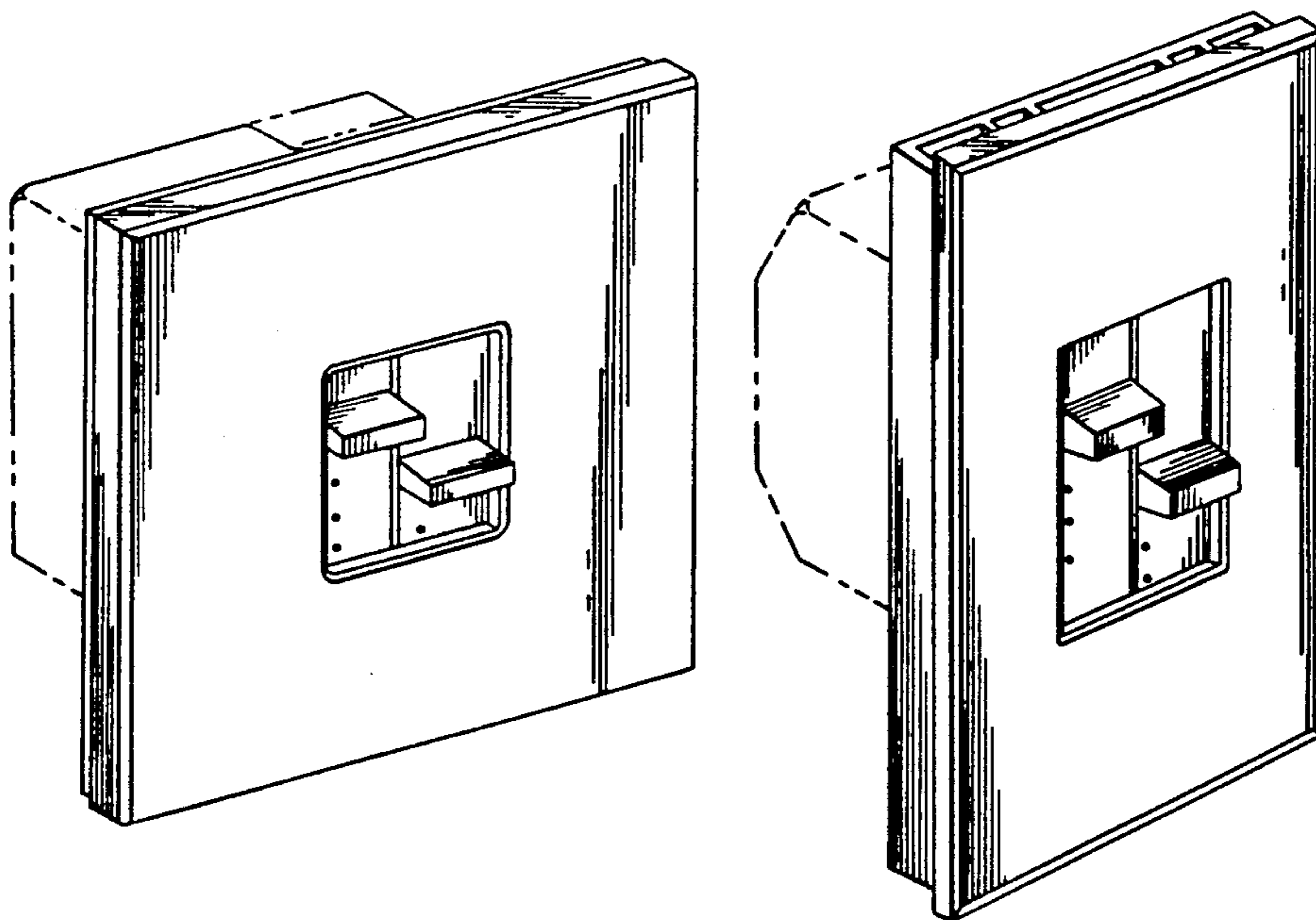

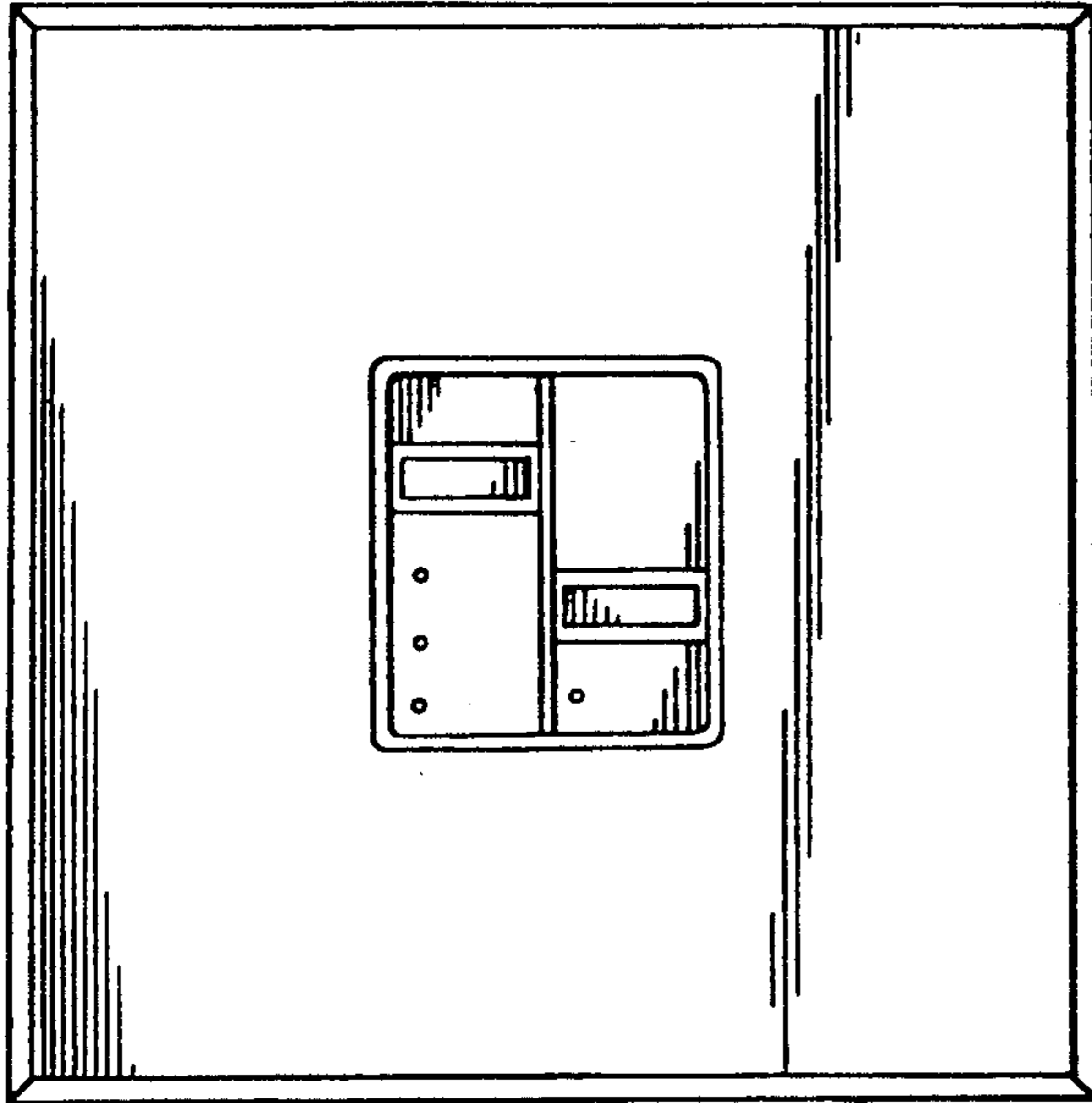

FIG. 1

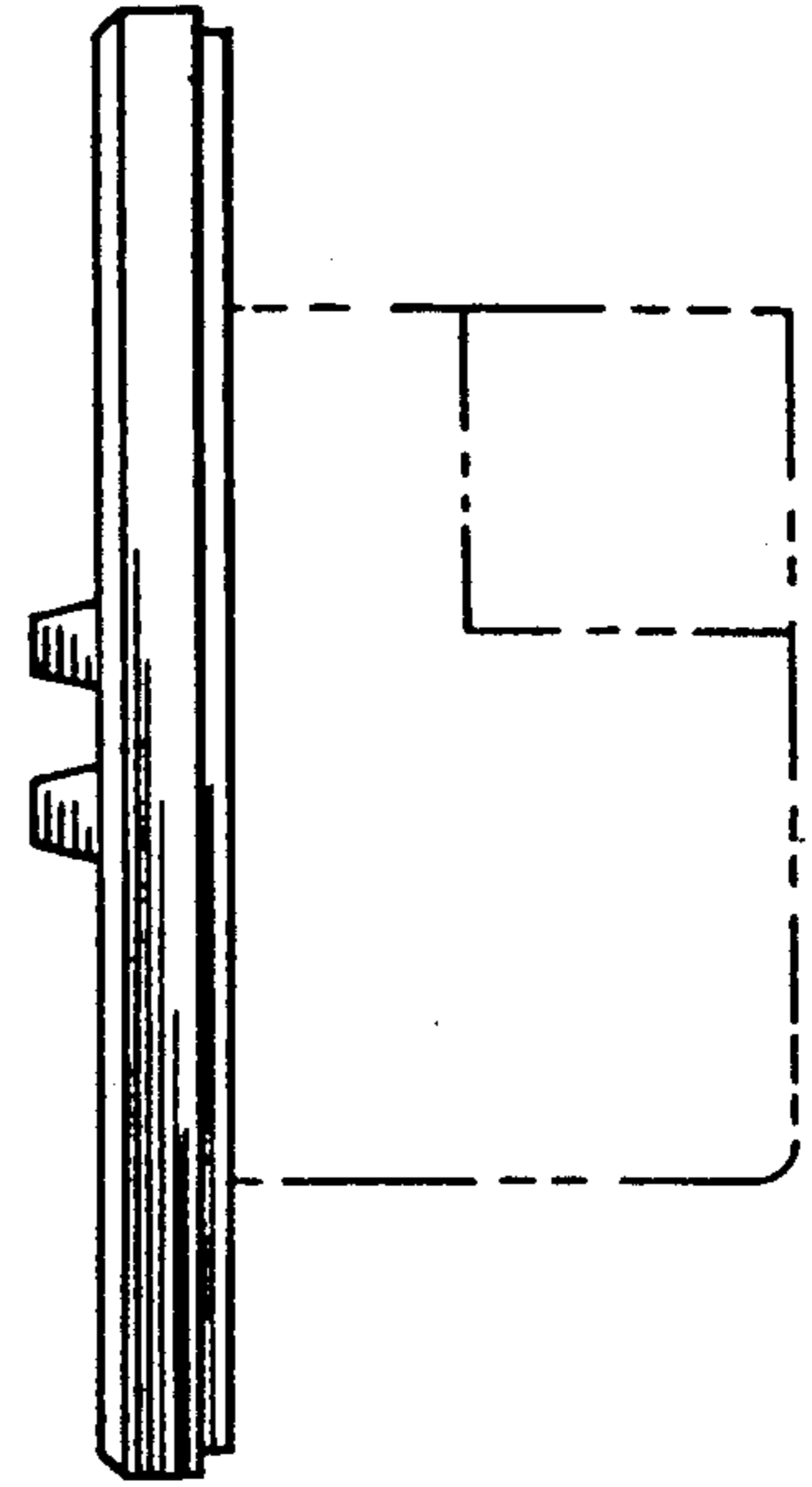

FIG. 2

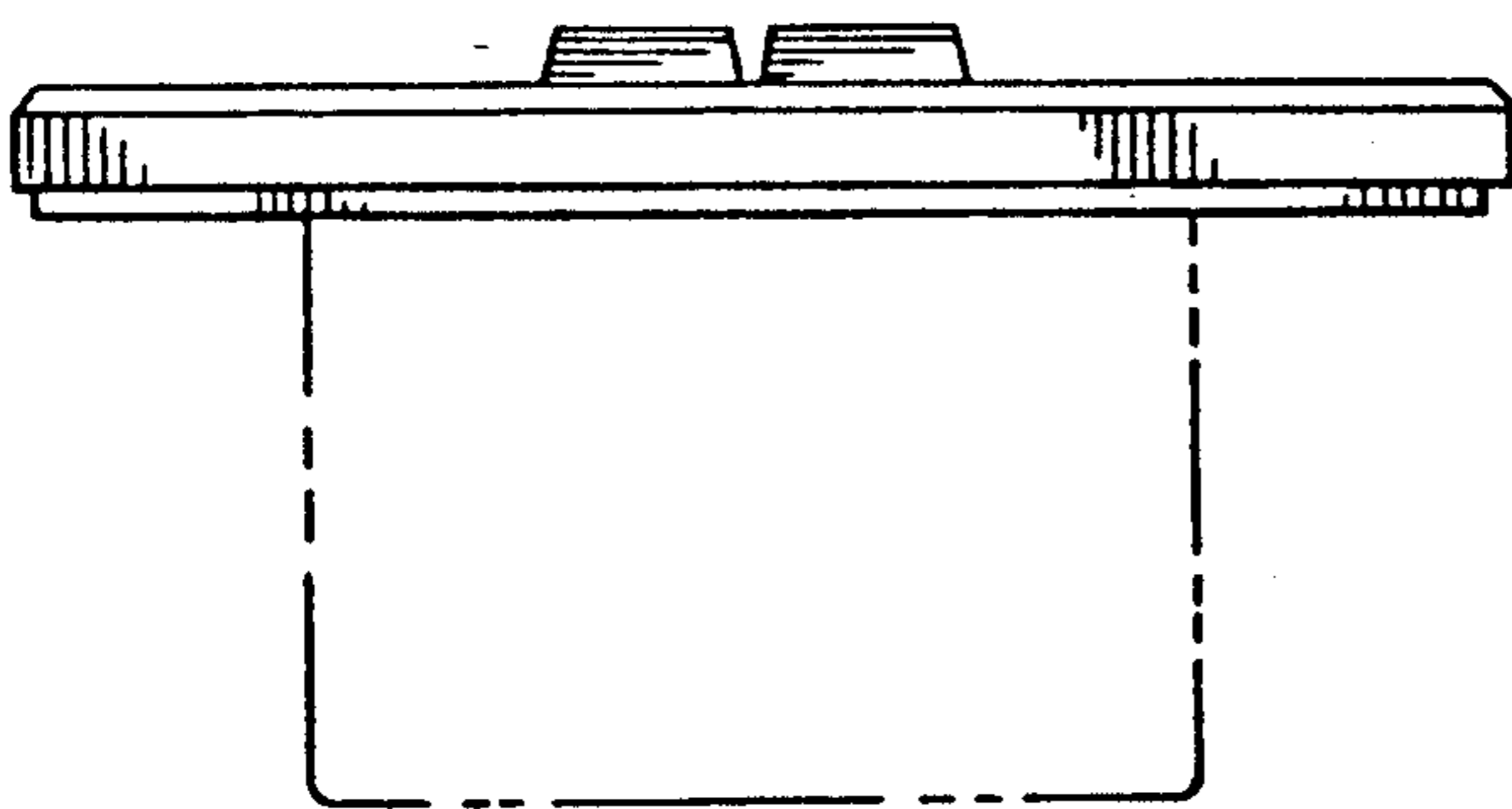

FIG. 3

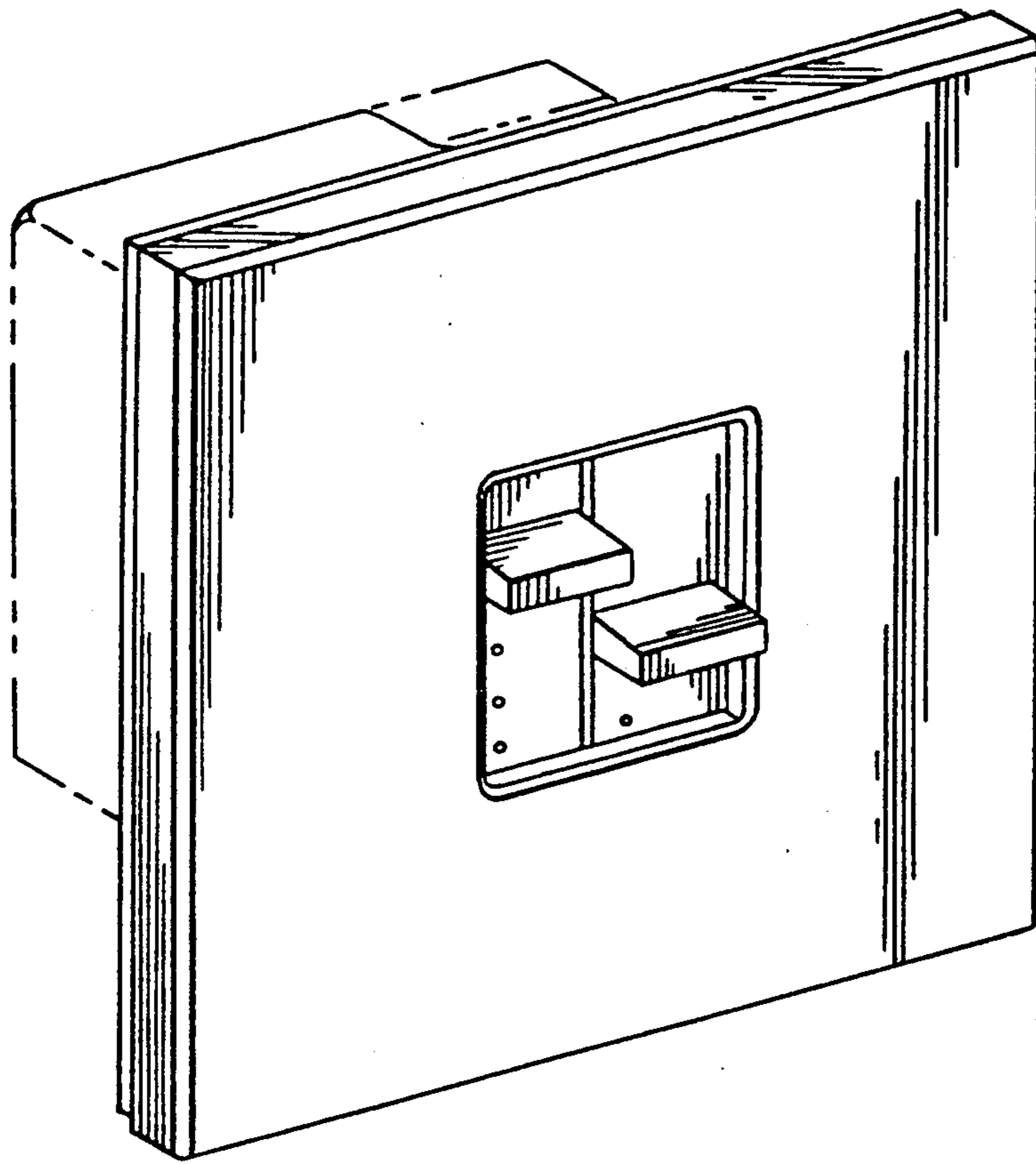

FIG. 4

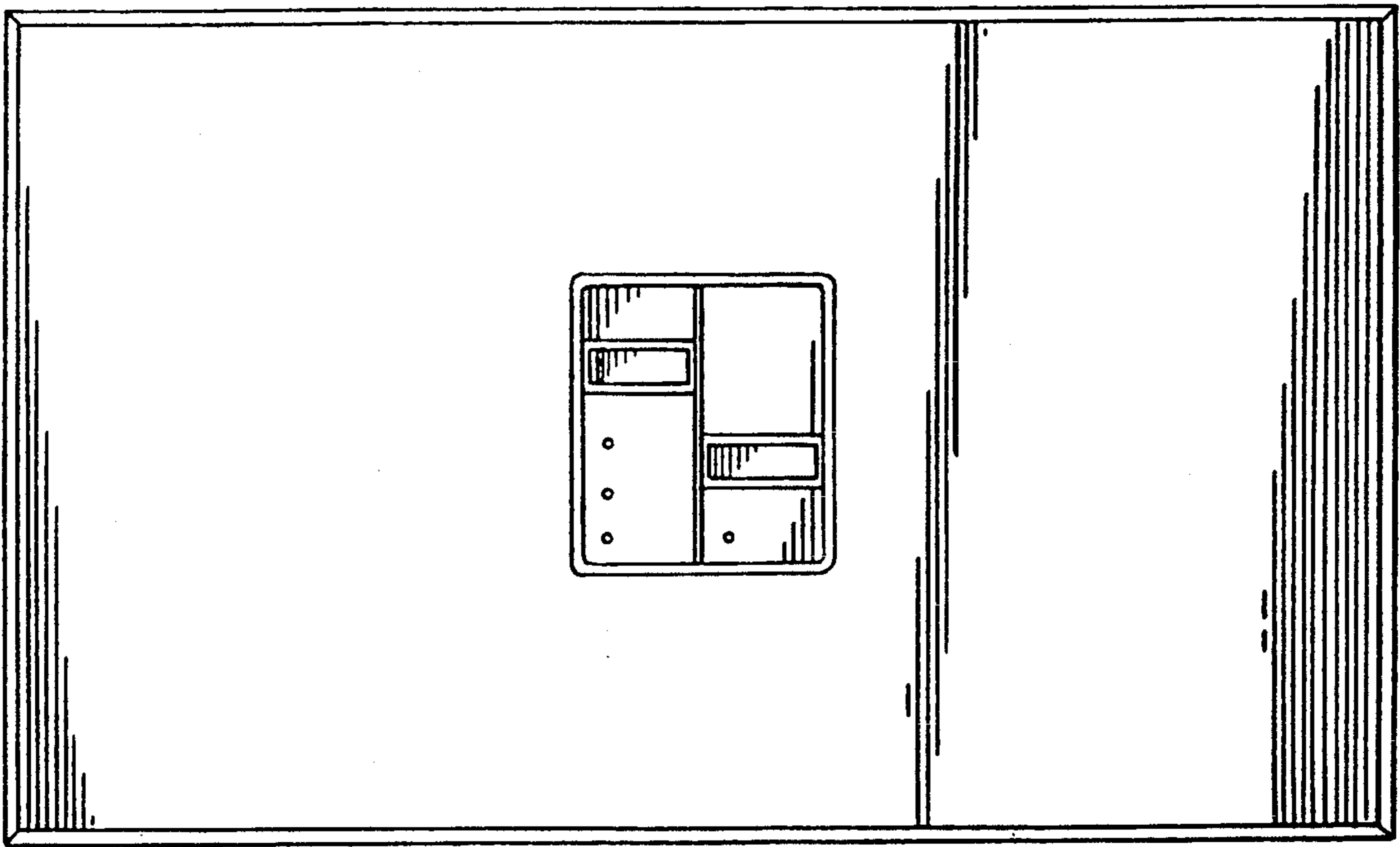

FIG. 5

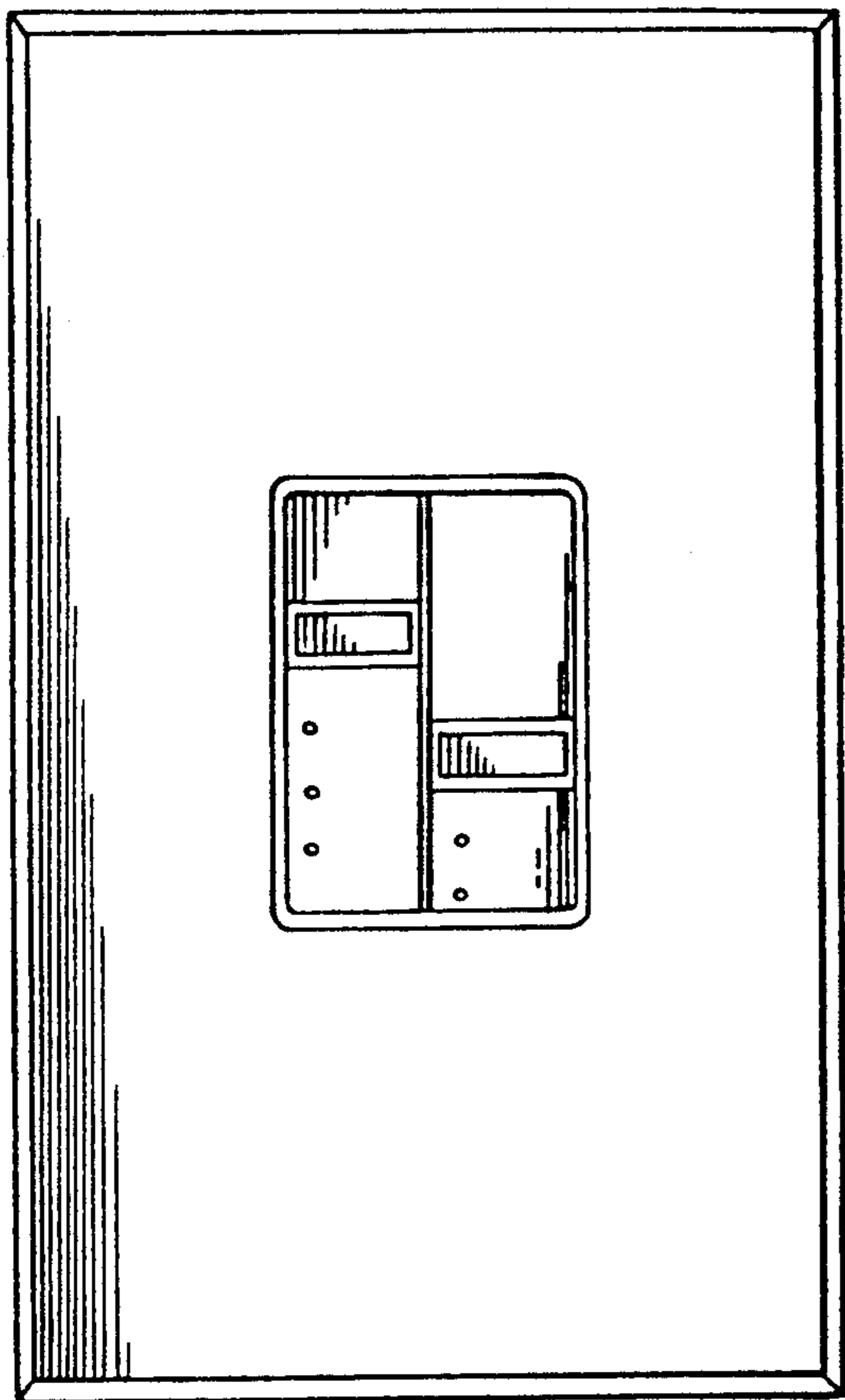

FIG. 6

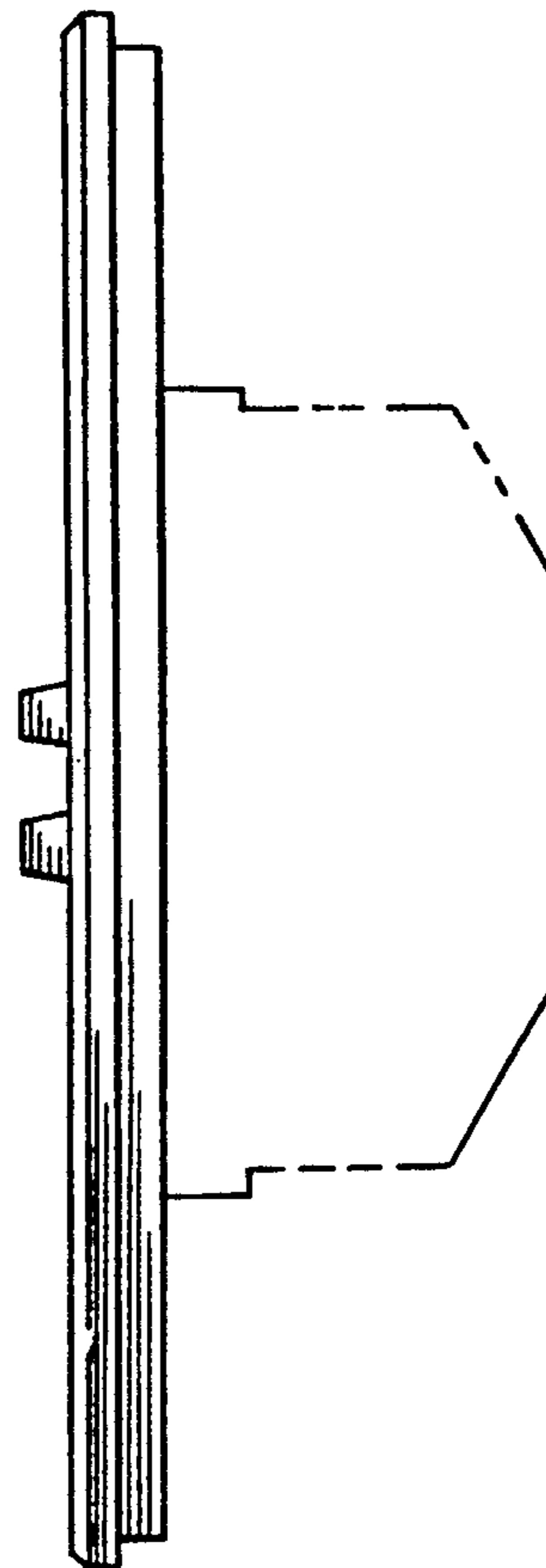

FIG. 7

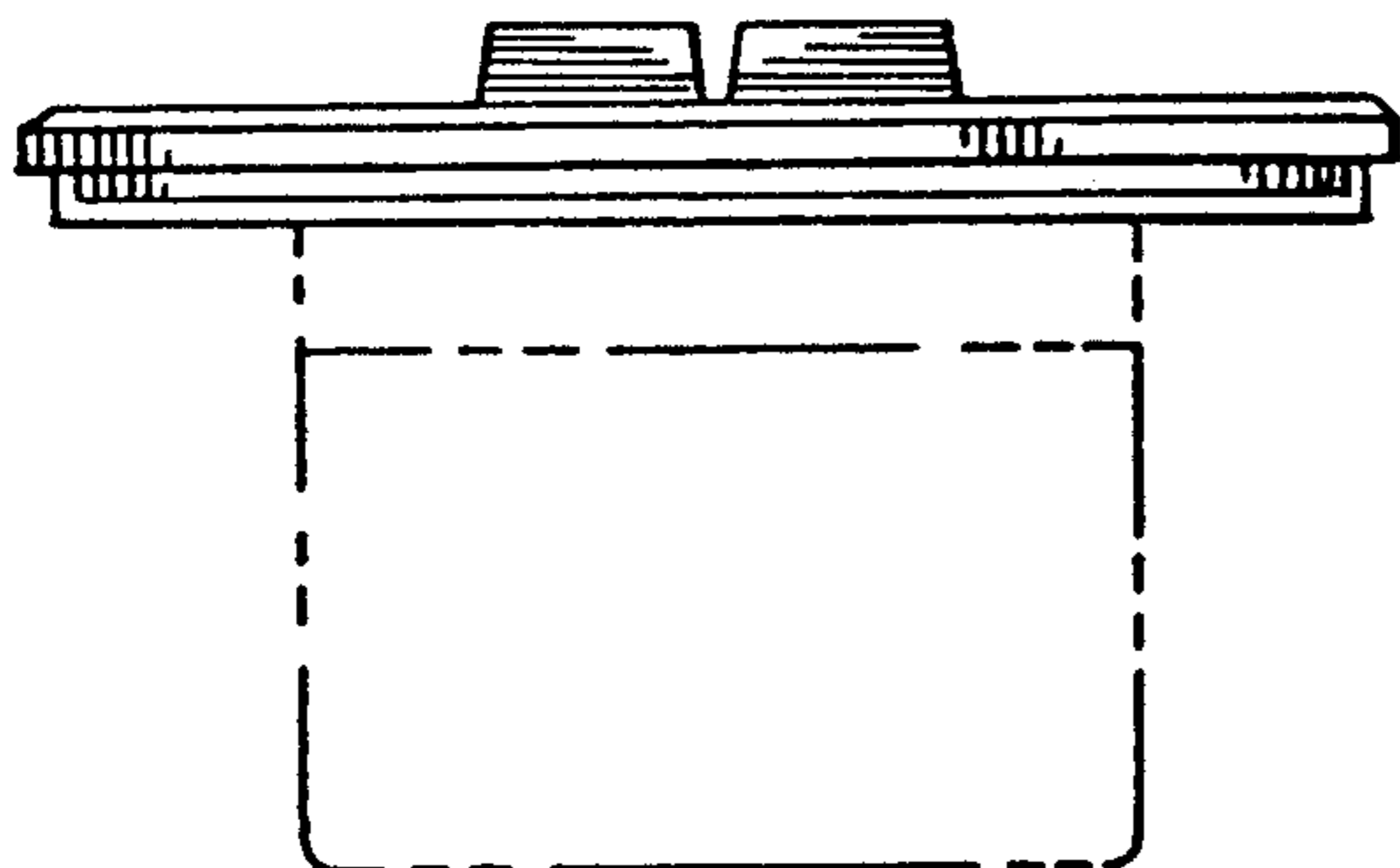

FIG. 8

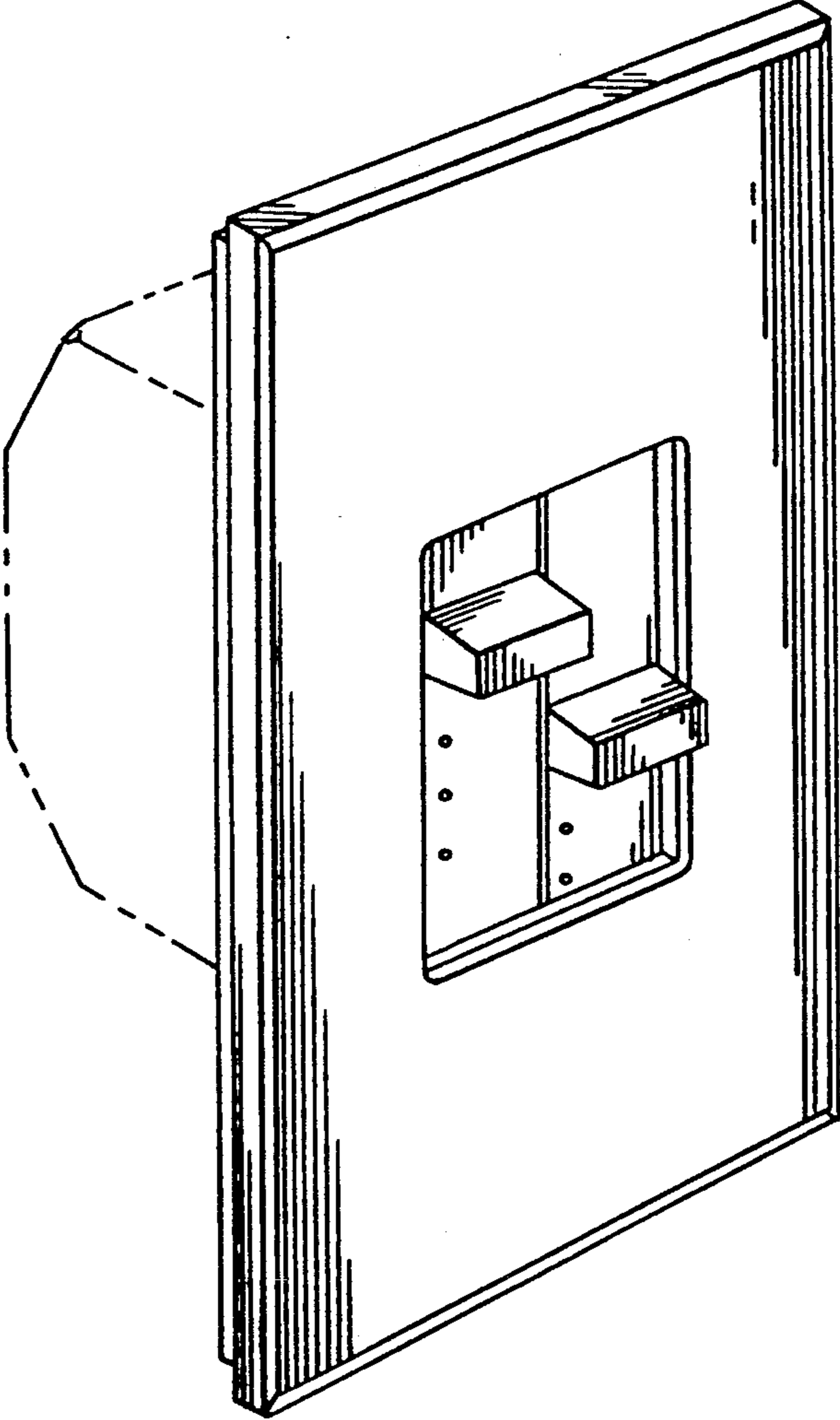

FIG. 9

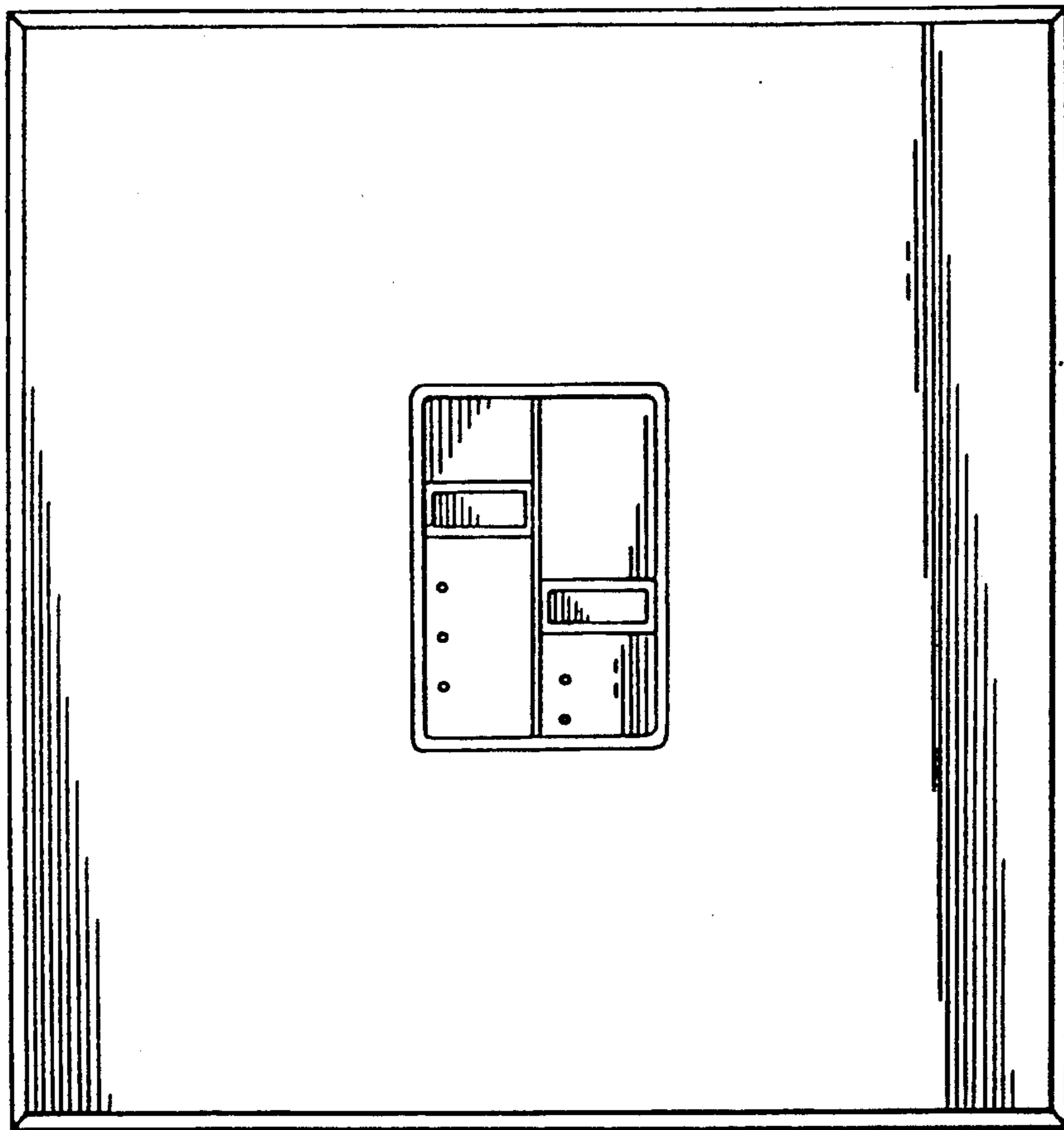

FIG. 10

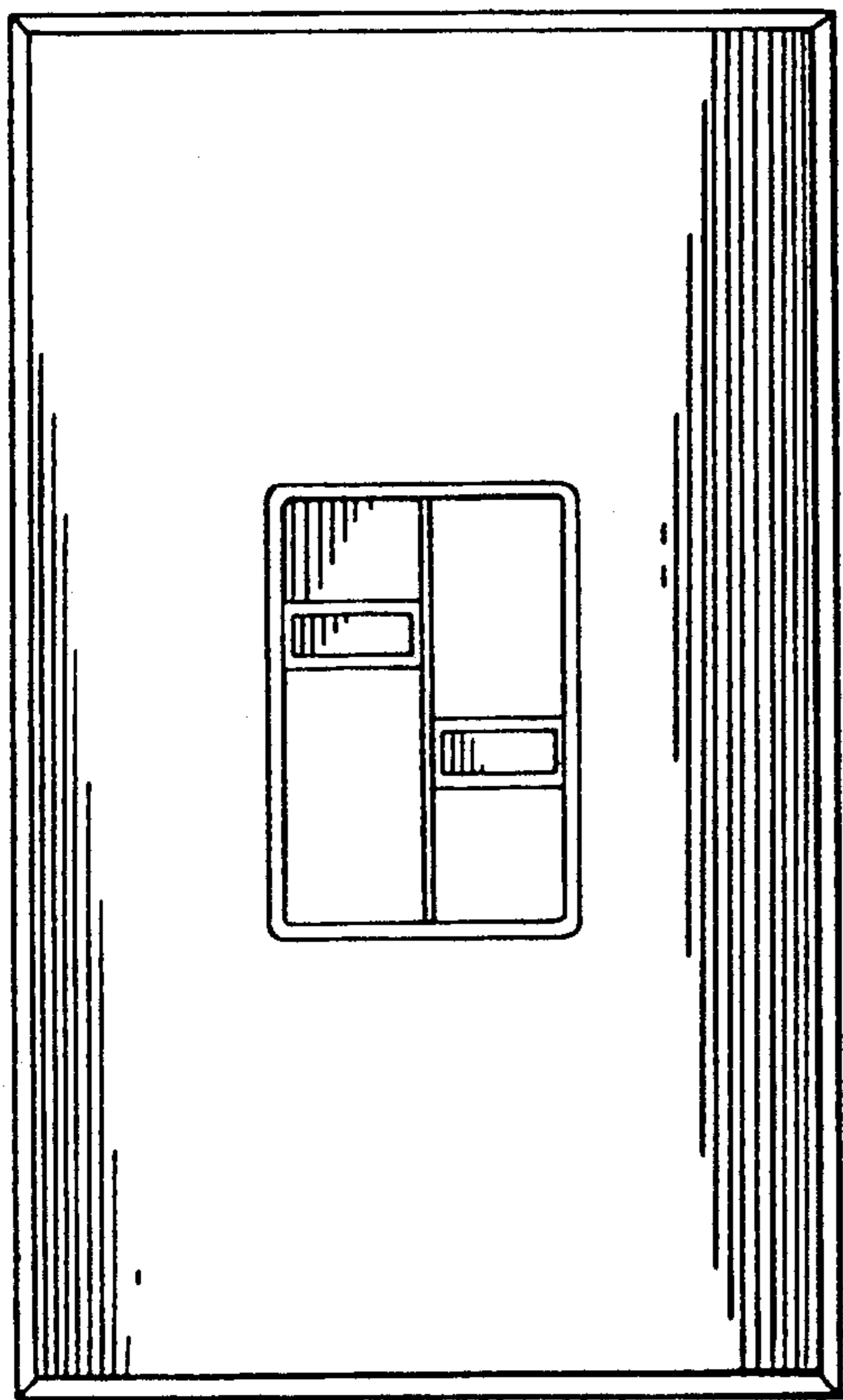

FIG. 11

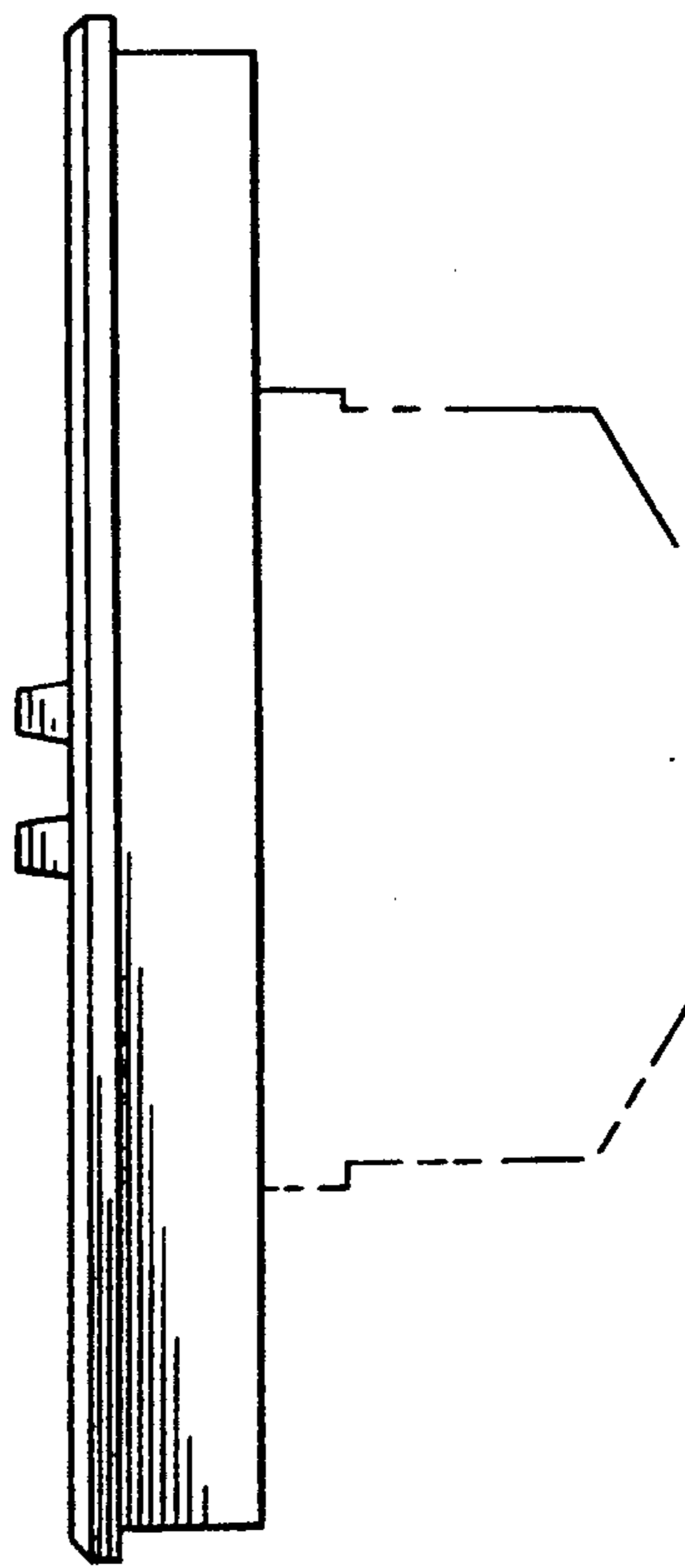

FIG. 12

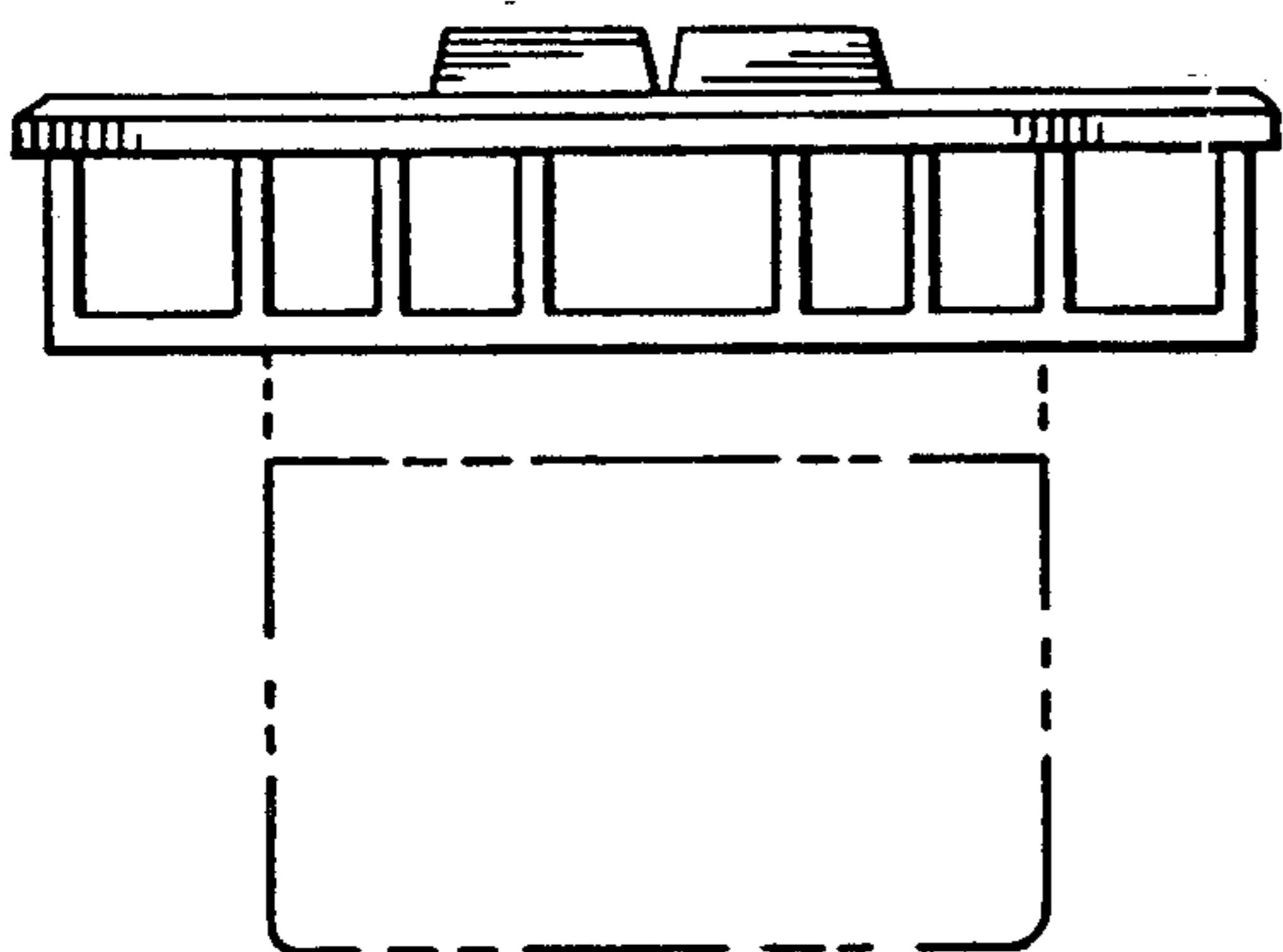

FIG. 13

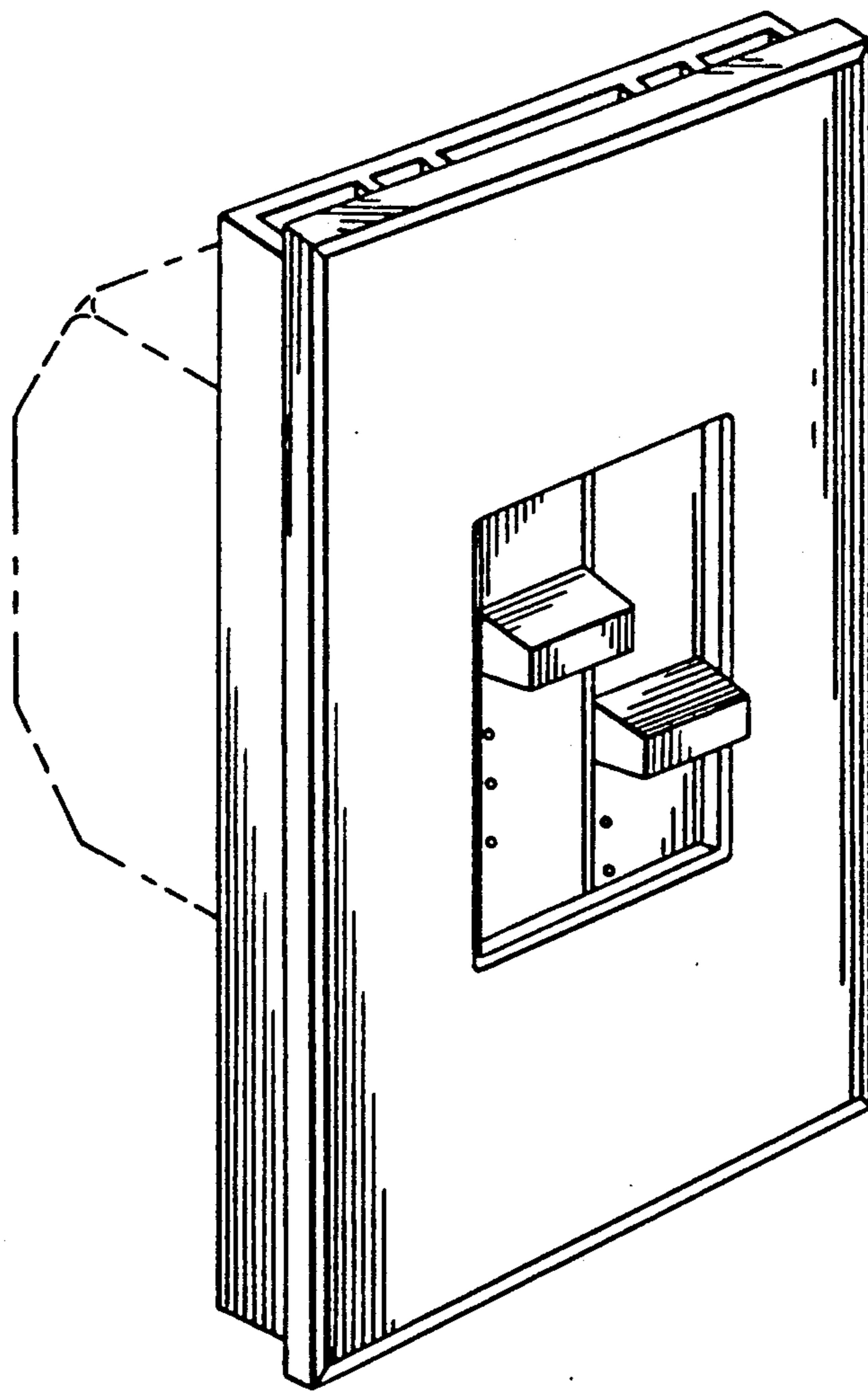

FIG. 14

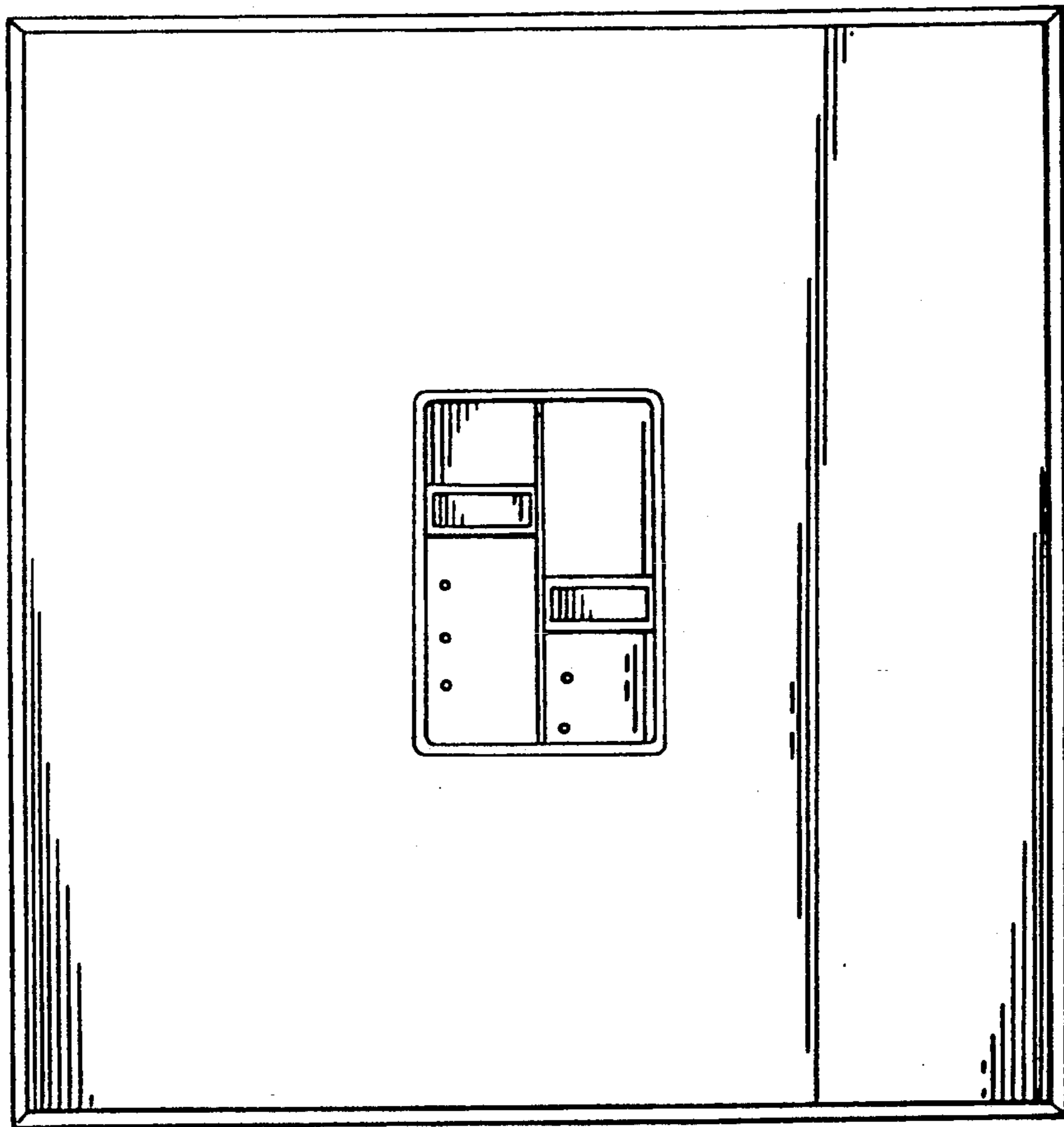

FIG. 15