



US00D325557S

United States Patent [19]

[11] Patent Number: **Des. 325,557**

Cummings et al.

[45] Date of Patent: **** Apr. 21, 1992**

[54] AIRPLANE

- D. 191,149 8/1961 Eaton D12/342
- D. 256,792 9/1980 McComas et al. D12/337
- D. 317,432 6/1991 Cummings D12/337
- 3,592,415 7/1971 Walley 244/55

[75] Inventors: **Darold B. Cummings**, Hawthorne;
Todd S. Malik, Rancho Palos Verdes, both of Calif.

Primary Examiner—Kay H. Chin
Attorney, Agent, or Firm—Charles T. Silberberg

[73] Assignee: **Rockwell International Corporation**, Seal Beach, Calif.

[57] **CLAIM**

[**] Term: **14 Years**

The ornamental design for an airplane, as shown and described.

[21] Appl. No.: **492,178**

[22] Filed: **Mar. 12, 1990**

DESCRIPTION

[52] U.S. Cl. **D12/337; D12/342**

FIG. 1 is a top plan view of an airplane showing our new design;

[58] Field of Search **D12/319, 337, 342, 338; 244/45 A, 15, 46**

FIG. 2 is a front elevational view thereof;

FIG. 3 is a rear elevational view thereof;

FIG. 4 is a bottom plan view thereof; and,

FIG. 5 is a left side elevational view thereof, the right side being a mirror image thereof.

[56] **References Cited**

U.S. PATENT DOCUMENTS

- D. 180,135 4/1957 Calhoun D12/342

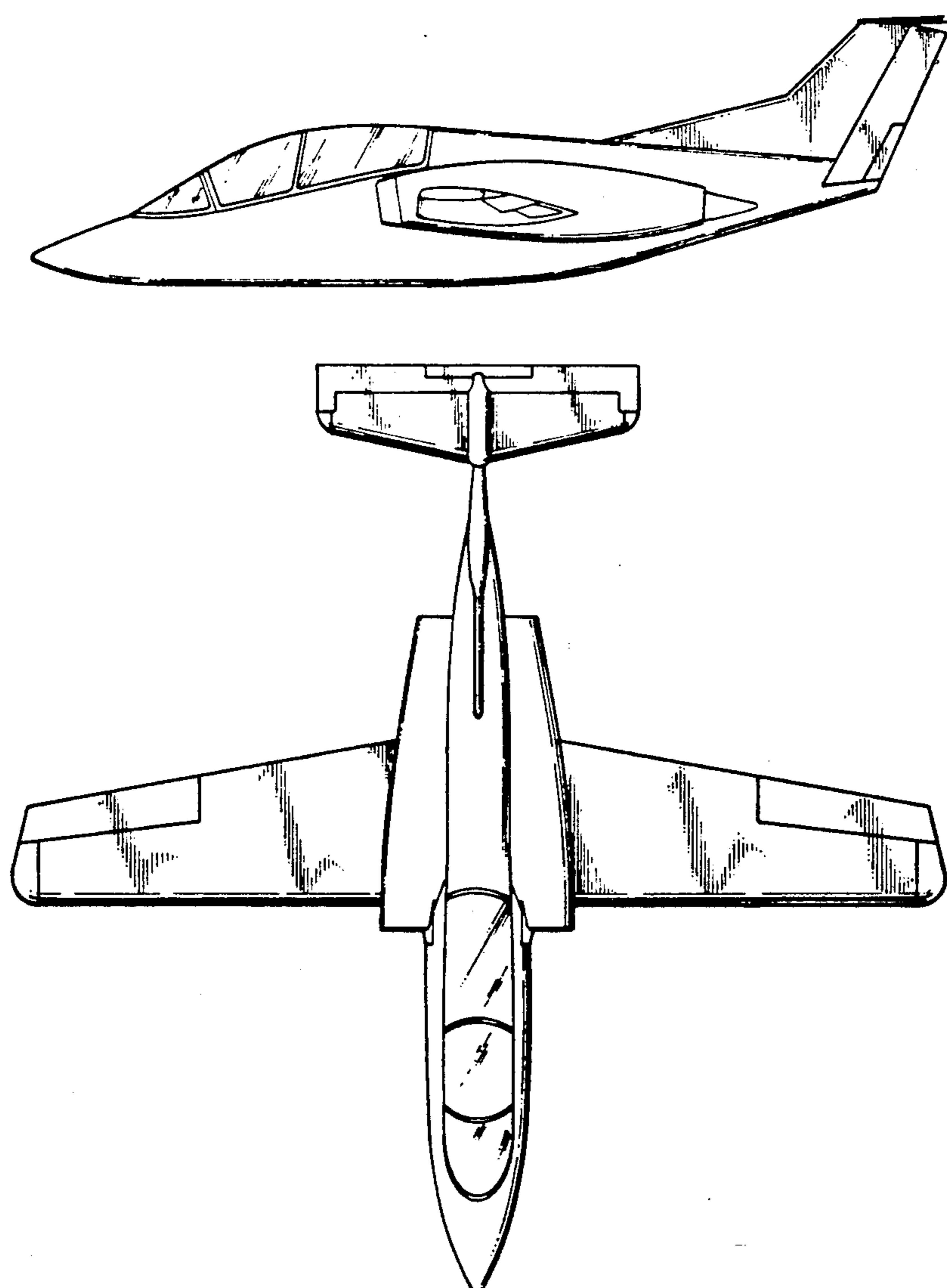

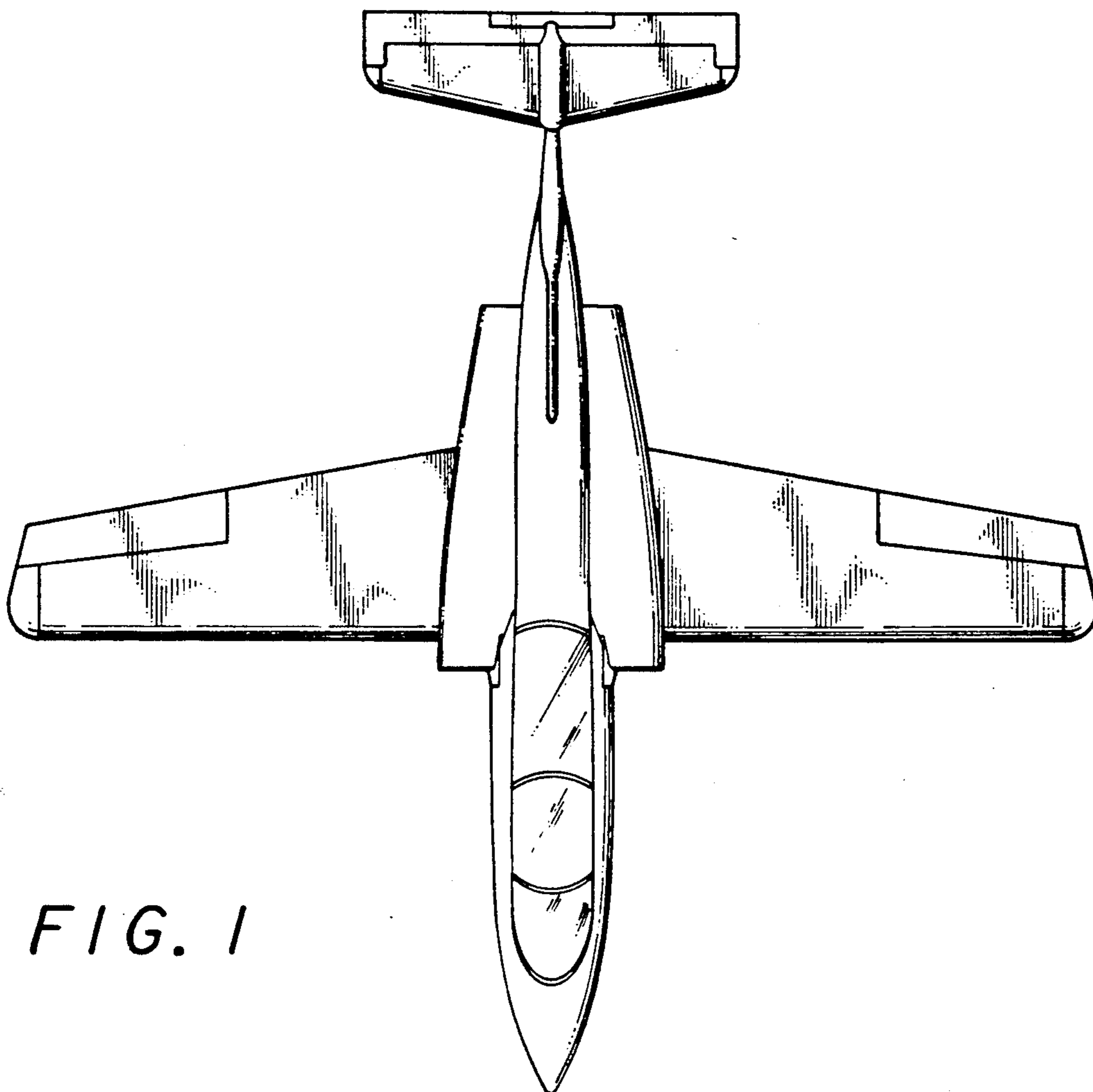

FIG. 1

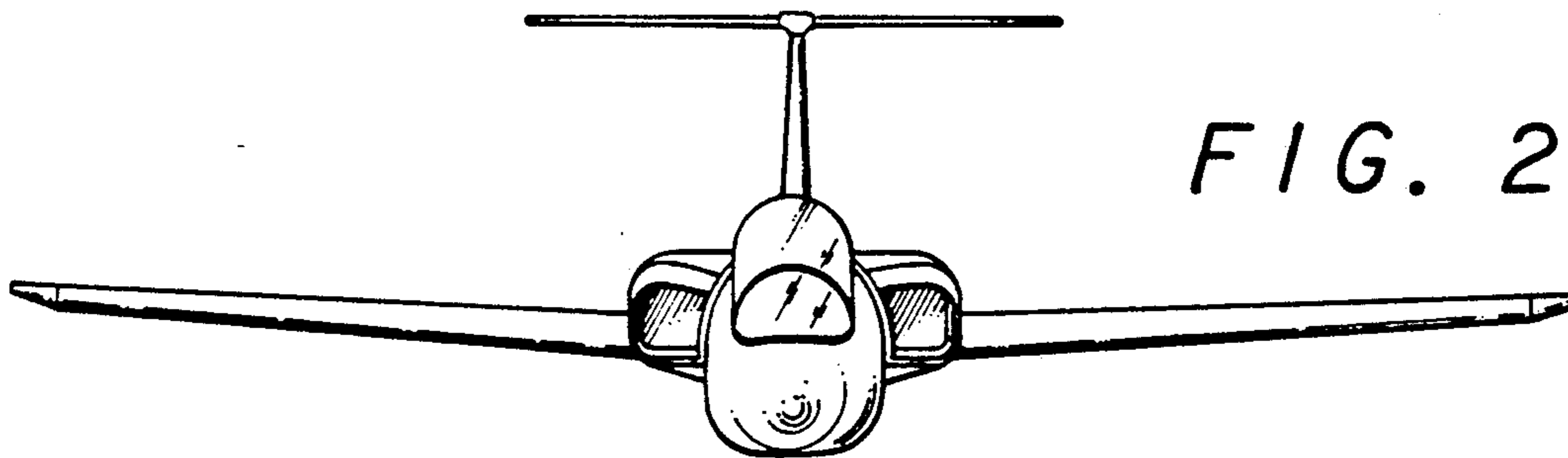

FIG. 2

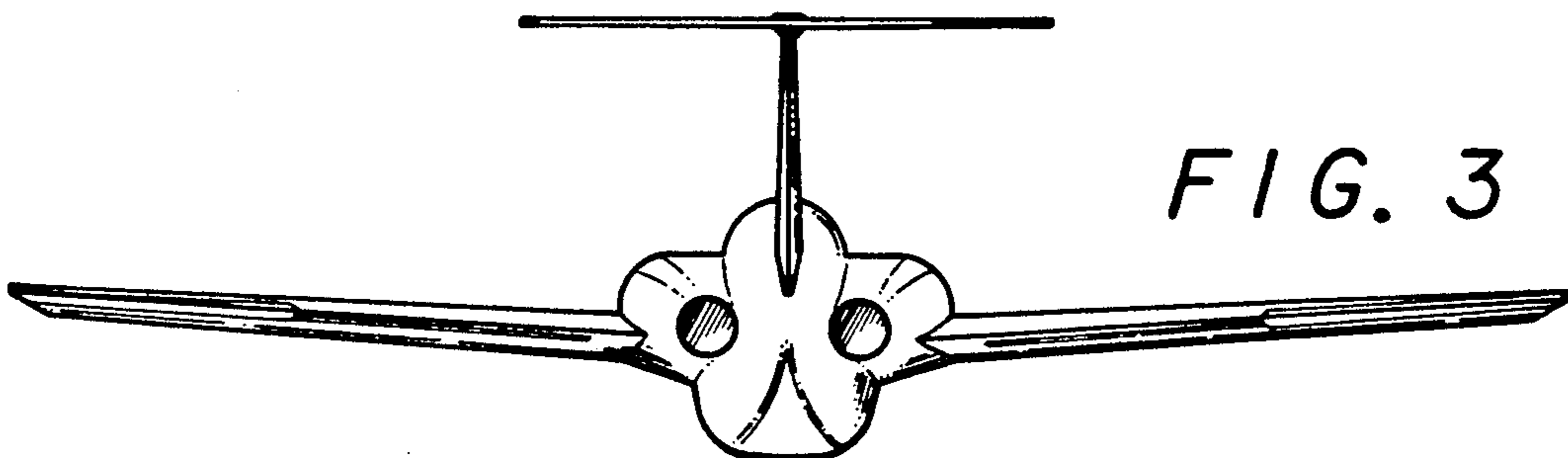

FIG. 3

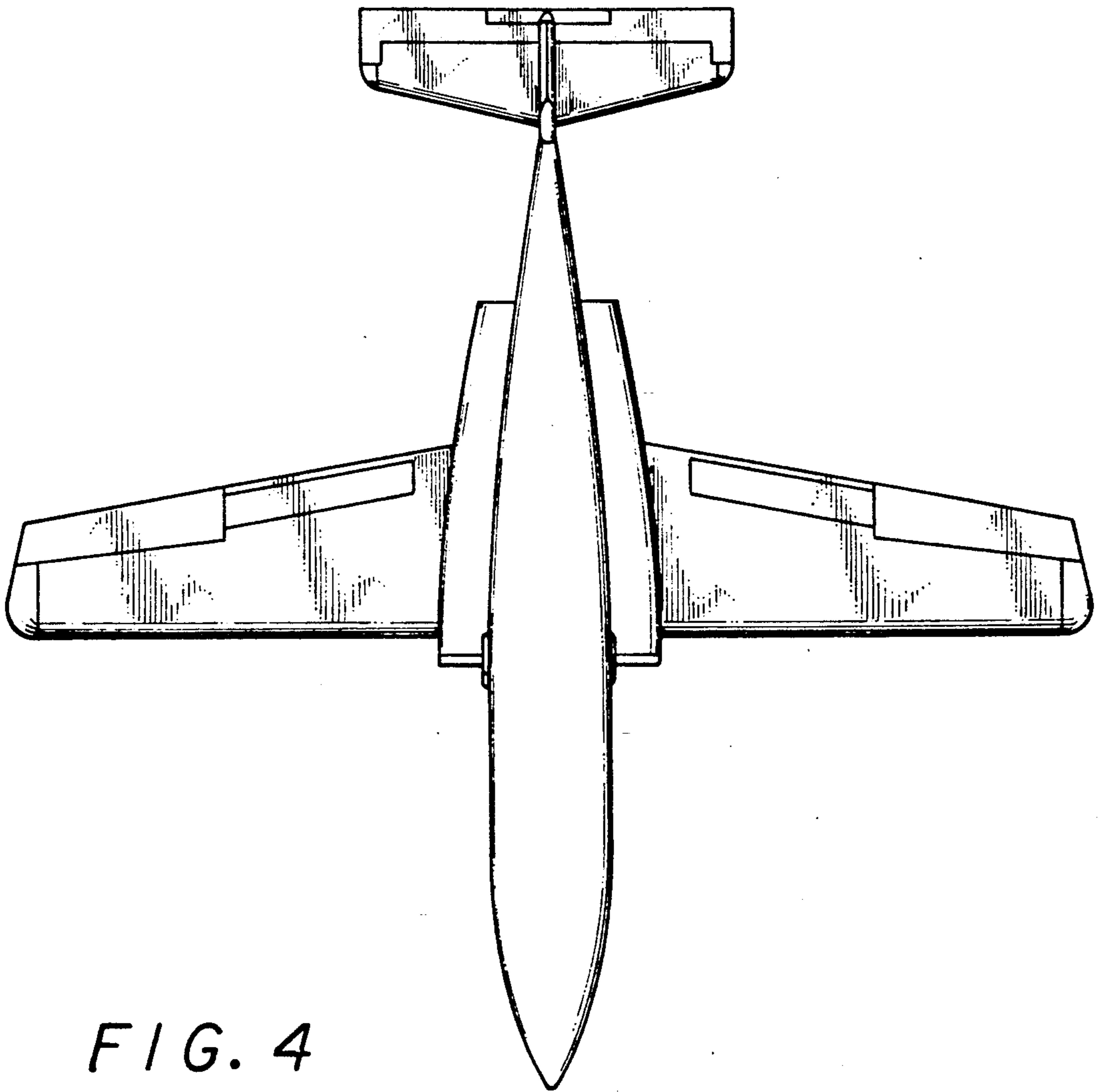

FIG. 4

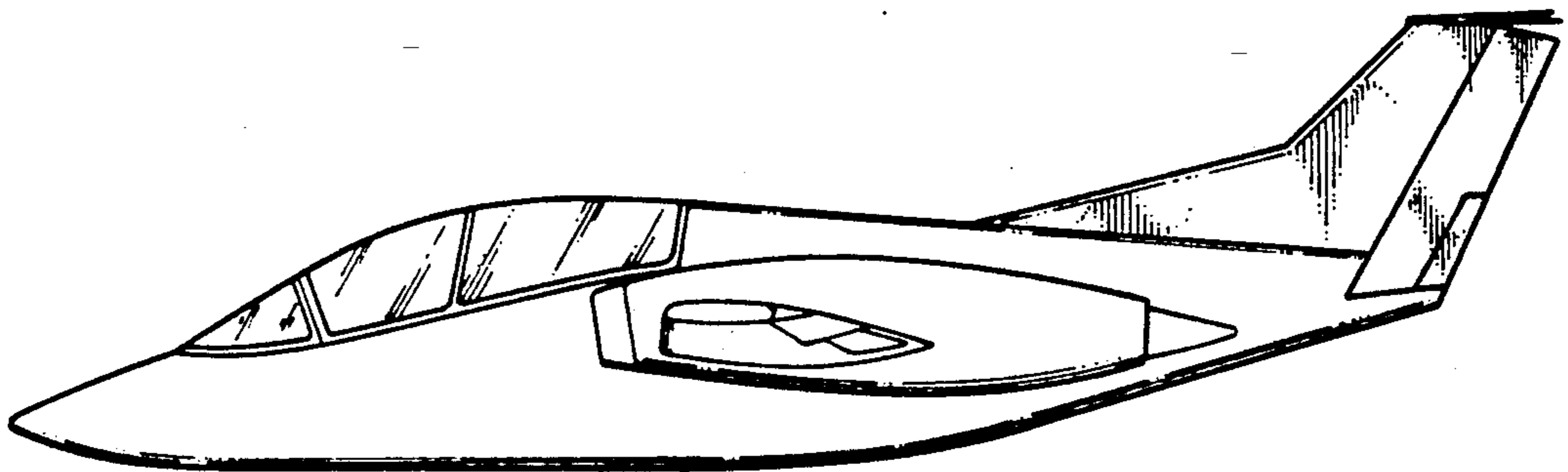

FIG. 5