



US00D325553S

United States Patent [19]

[11] Patent Number: **Des. 325,553**

Weiner et al.

[45] Date of Patent: **** Apr. 21, 1992**

[54] VEHICLE ATTACHED BICYCLE RACK

[76] Inventors: **Richard Weiner**, 722 Gettysburg Cir., Claremont, Calif. 91711; **Steven Ables**, 18232 Yukon Ave., Torrance, Calif. 90504; **Marc A. Ruggeri**, 5305 Carmelyn St., Torrance, Calif. 90503

[**] Term: **14 Years**

[21] Appl. No.: **429,864**

[22] Filed: **Oct. 31, 1989**

[52] U.S. Cl. **D12/158**

[58] Field of Search **D12/158; 224/42.03 B**

[56] References Cited

U.S. PATENT DOCUMENTS

4,400,129	8/1983	Eisenberg et al.	224/42.03 B
4,461,410	7/1984	Tartaglia	224/42.03 B
4,676,414	6/1987	Deguevara	224/42.03 B
4,901,896	2/1990	Speer	224/42.03 B
5,004,133	4/1991	Wyers	224/42.03 B

OTHER PUBLICATIONS

American Bicyclist & Motorcyclist, Jan. 1987, p. 14, the bike slider bike rack.

Primary Examiner—James M. Gandy

Assistant Examiner—Melody Brown

Attorney, Agent, or Firm—Koda and Androlia

[57] CLAIM

The ornamental design for a vehicle attached bicycle rack, as shown.

DESCRIPTION

FIG. 1 is a perspective view of a vehicle attached bicycle rack showing our new design; FIG. 2 is a rear elevational view thereof; FIG. 3 is a front elevational view thereof; FIG. 4 is a top plan view thereof; FIG. 5 is a bottom plan view thereof; FIG. 6 is a left side elevational view thereof; and, FIG. 7 is a right side elevational view thereof.

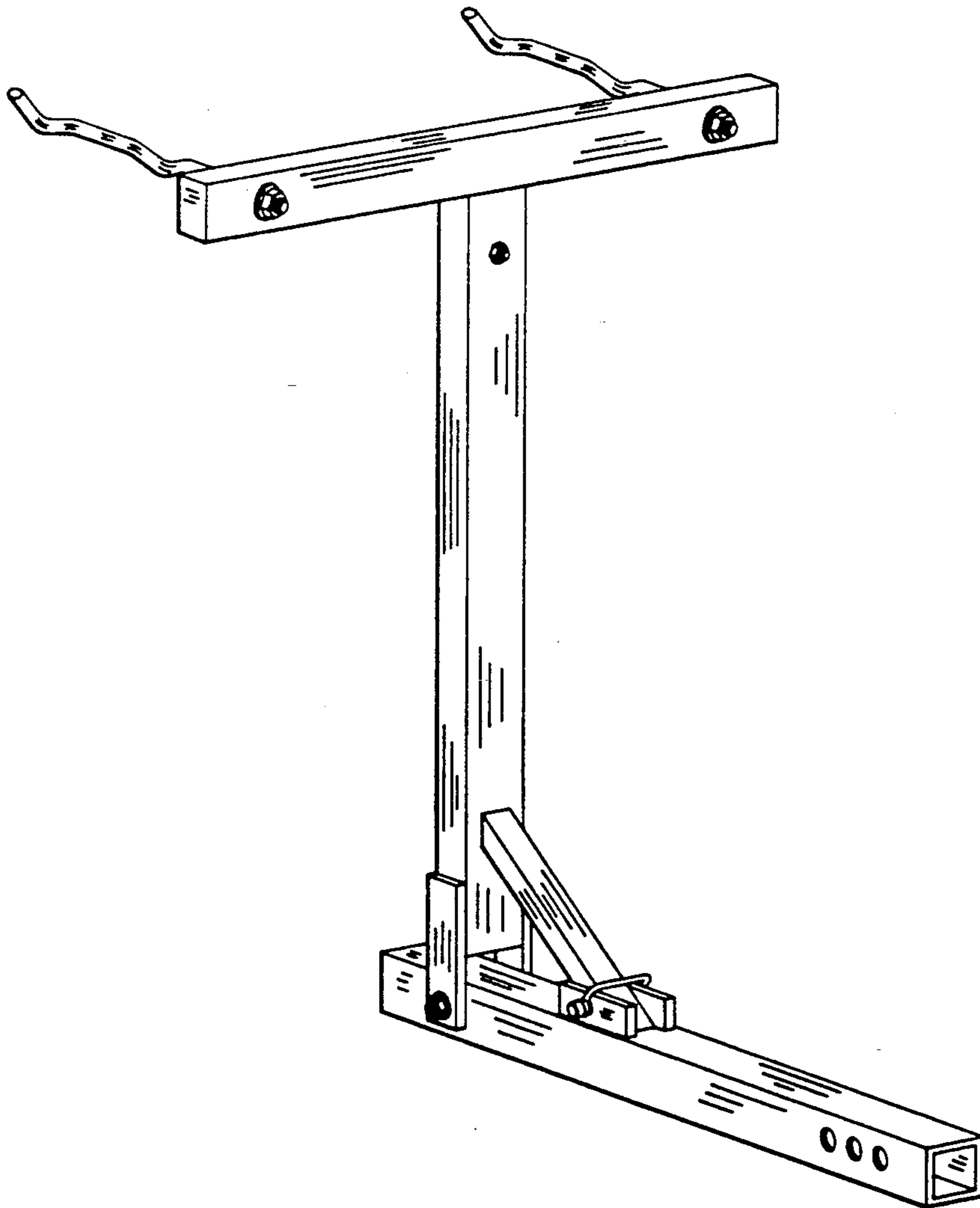

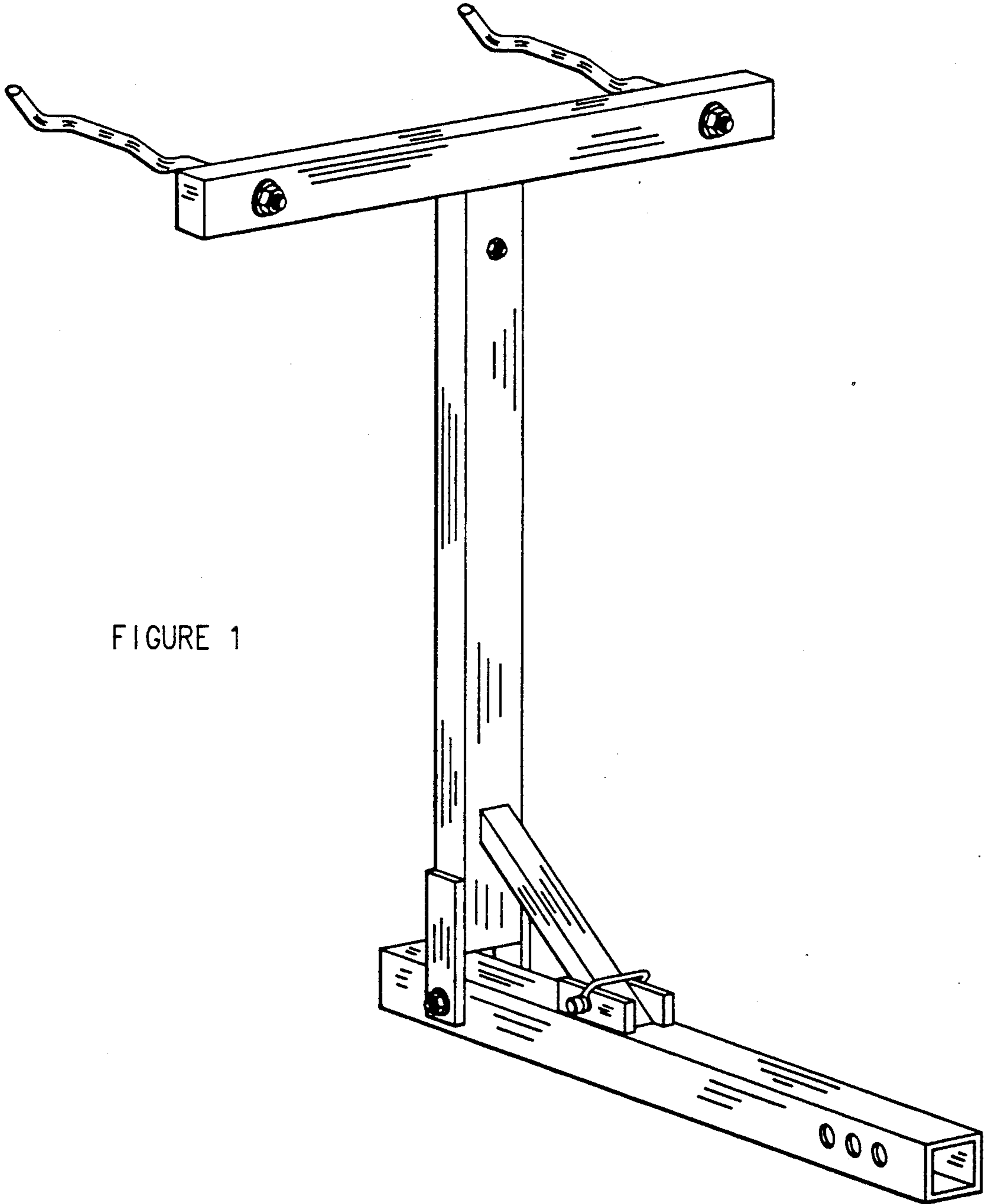

FIGURE 1

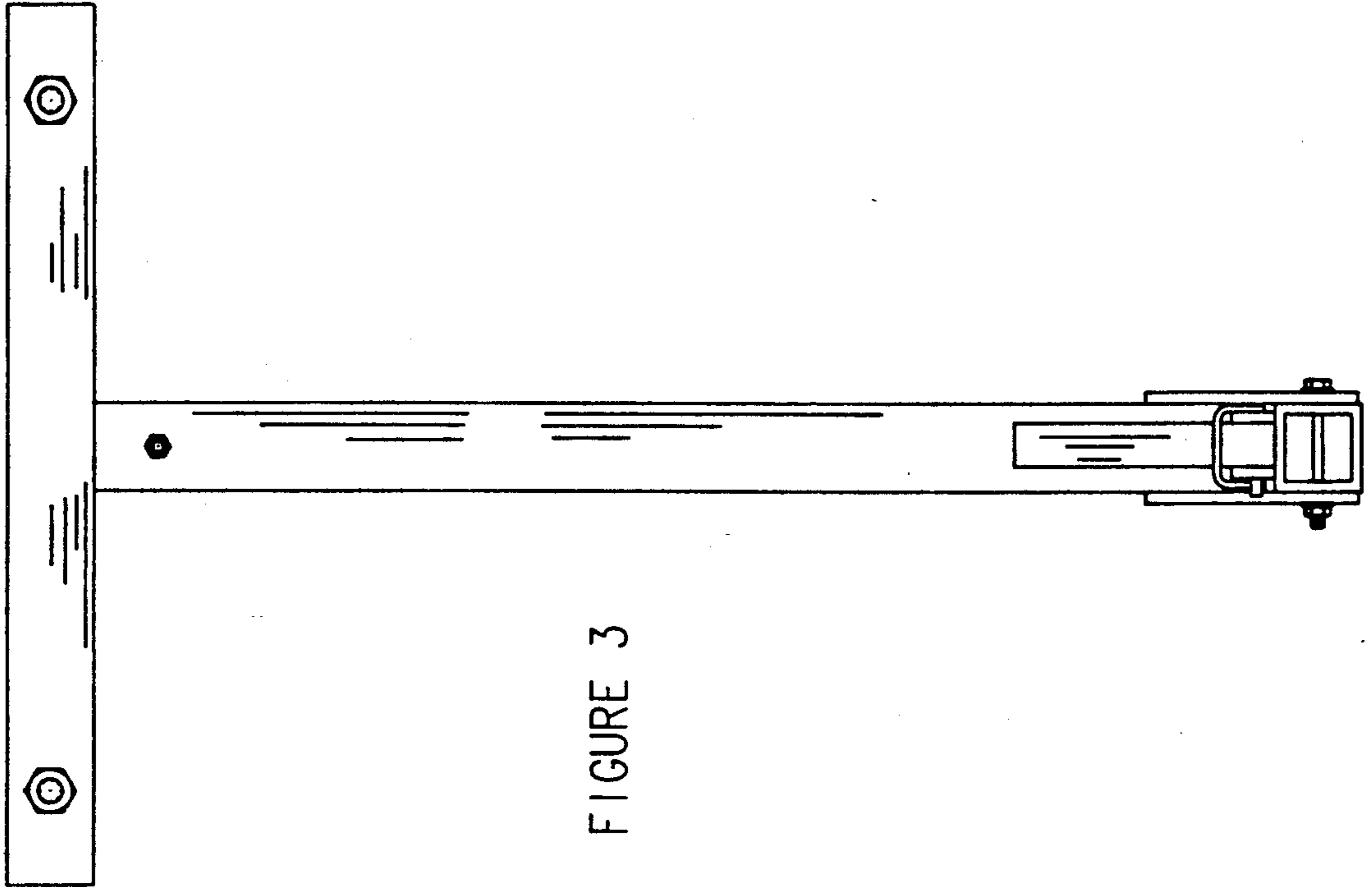

FIGURE 3

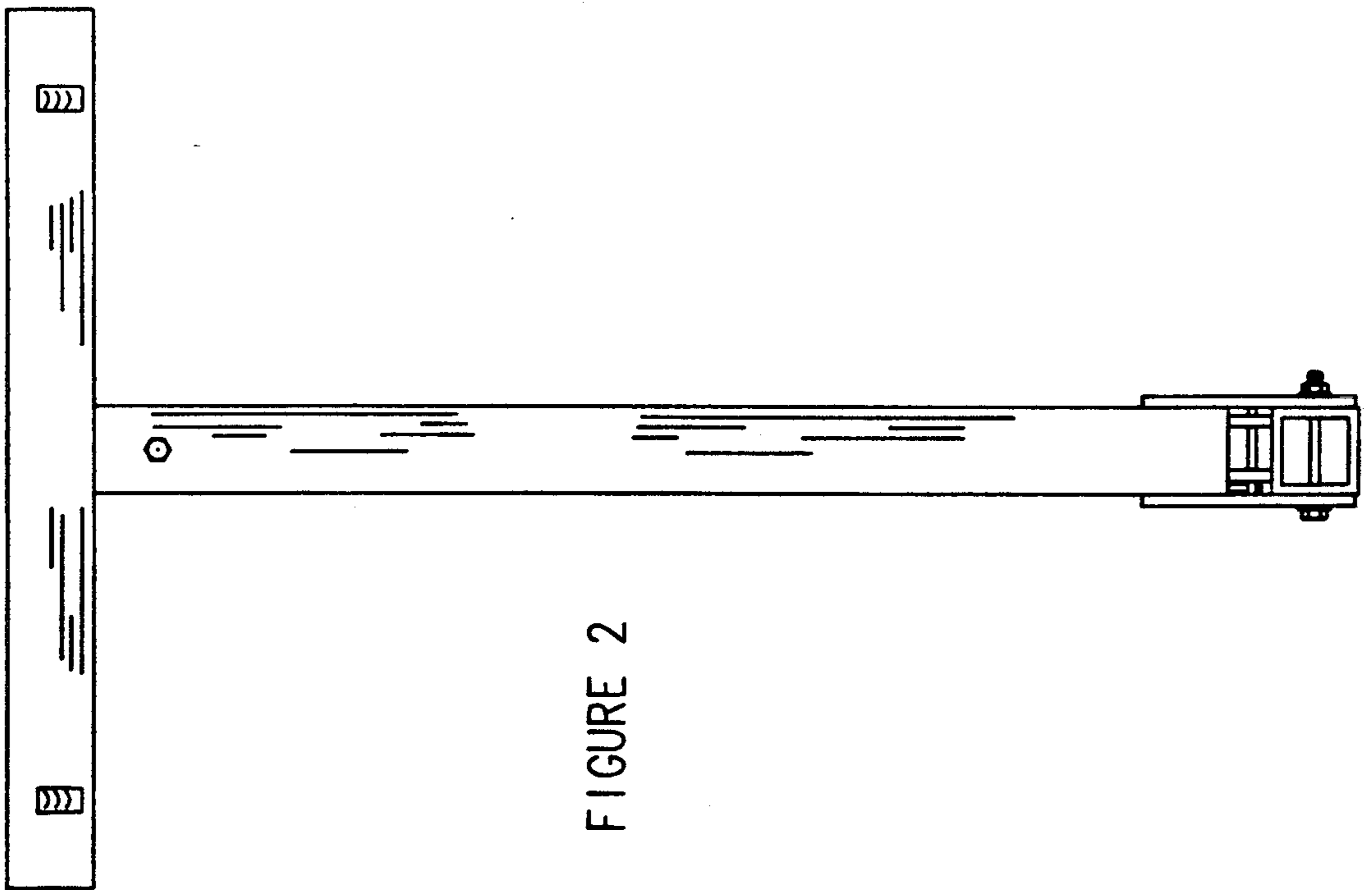

FIGURE 2

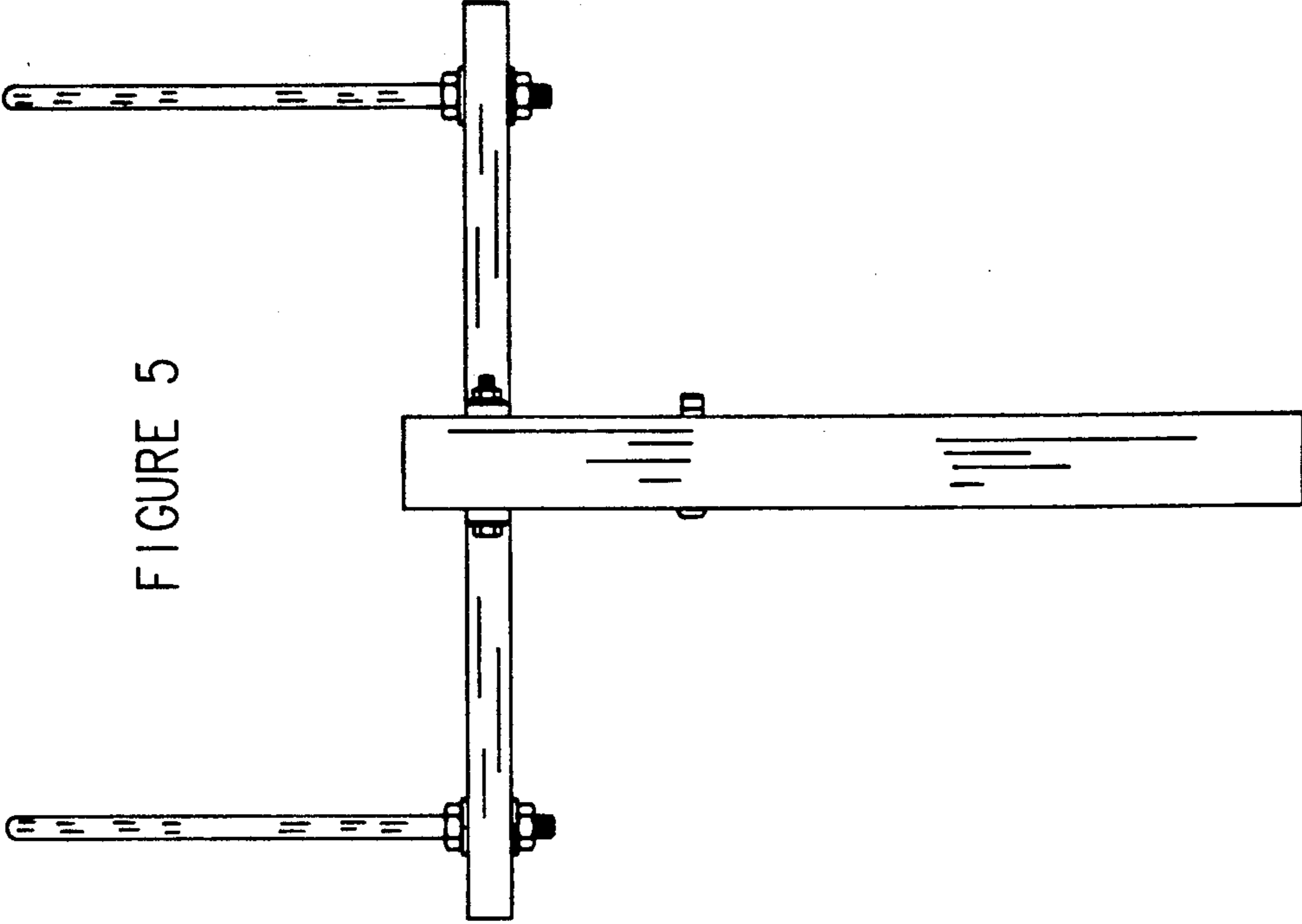

FIGURE 5

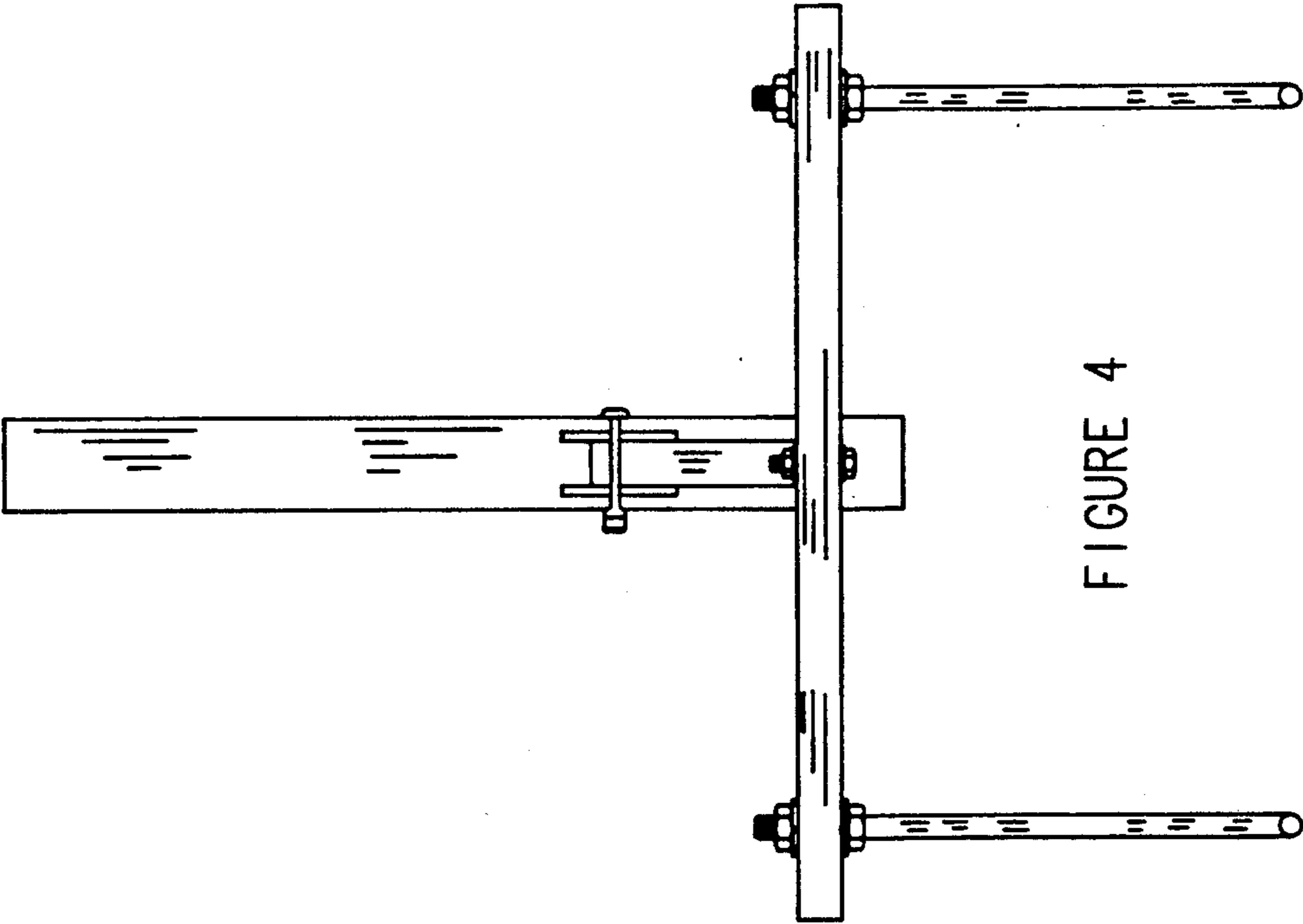

FIGURE 4

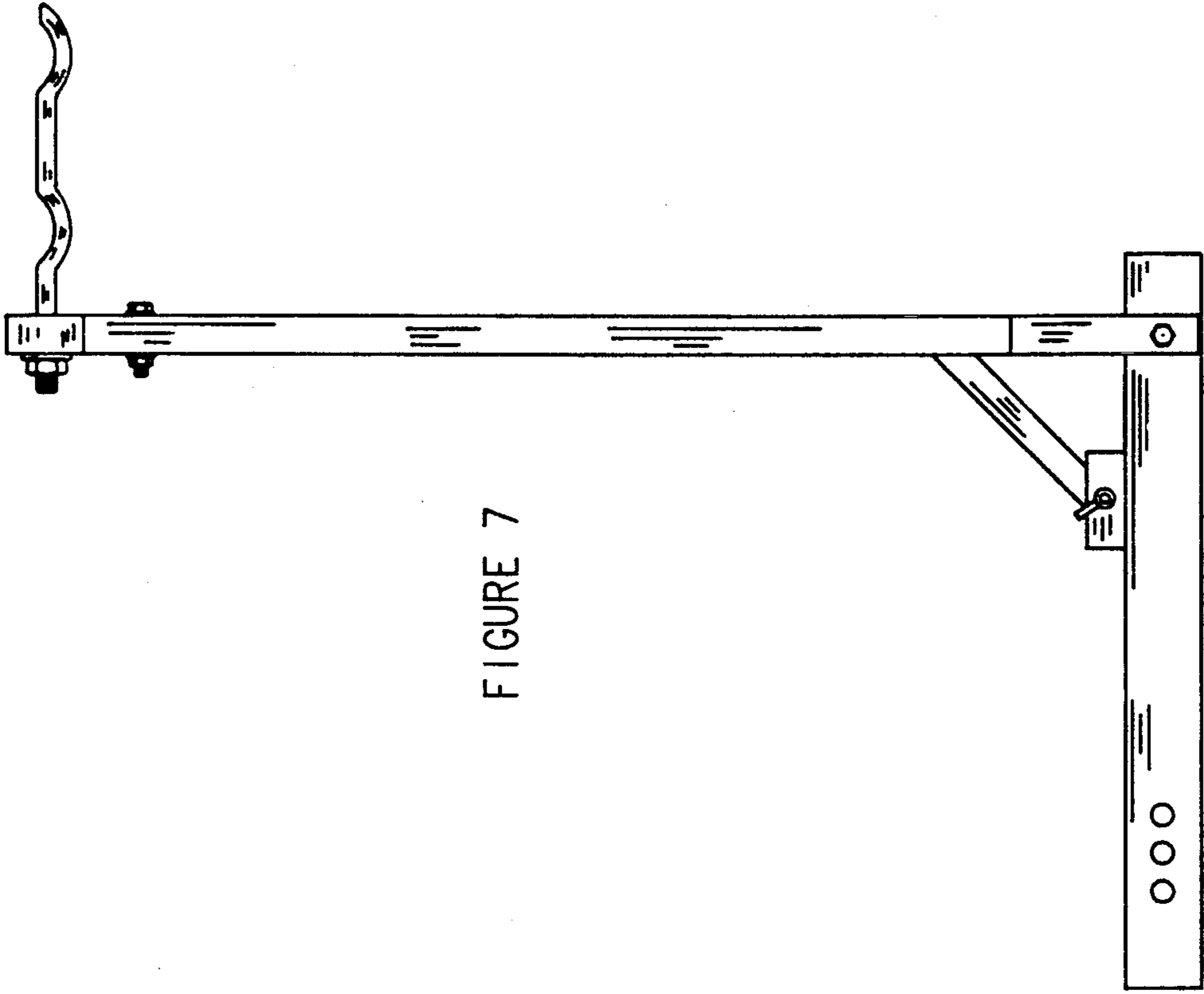

FIGURE 7

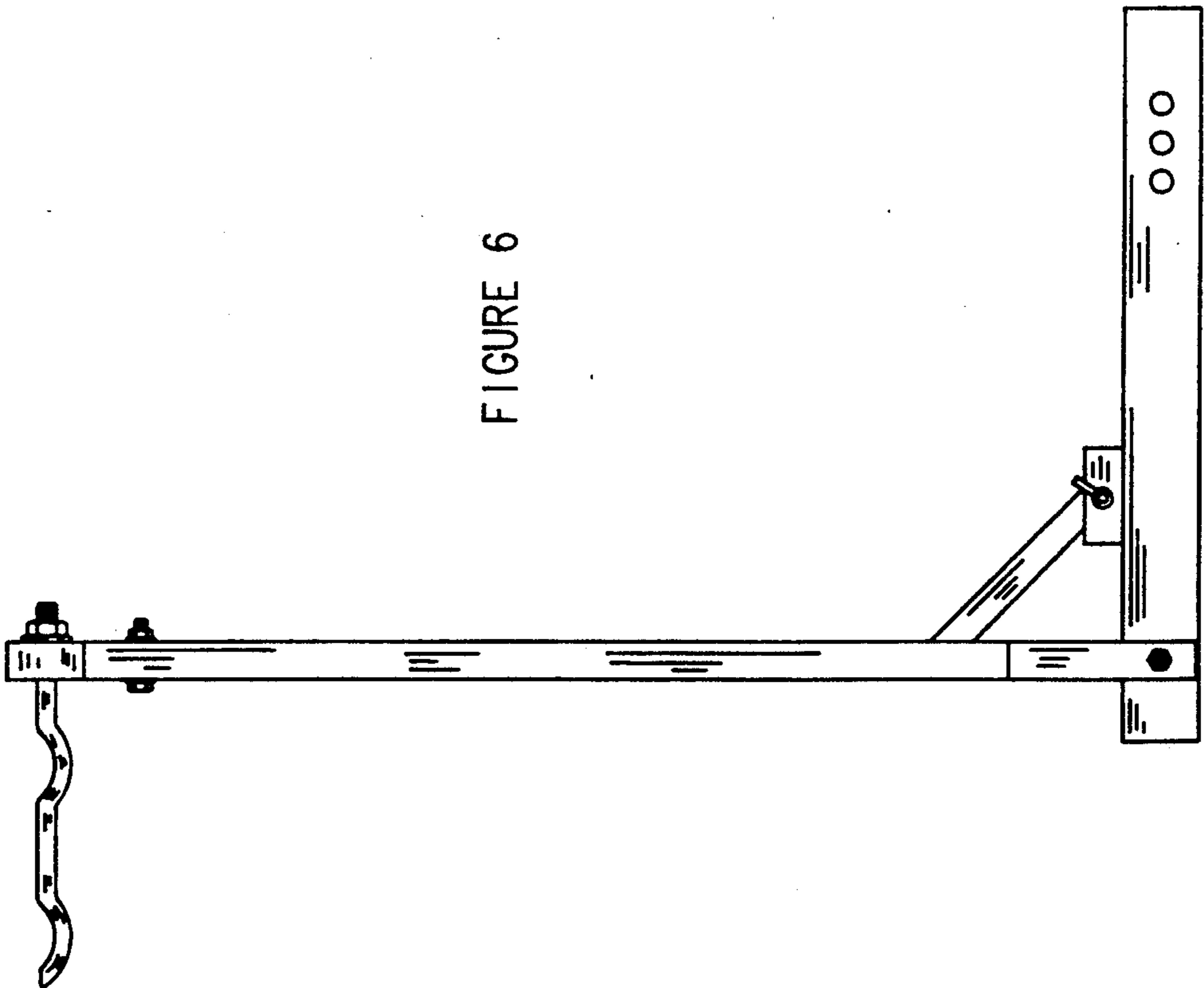

FIGURE 6