



US00D325511S

# United States Patent [19]

[11] Patent Number: **Des. 325,511**

Jan et al.

[45] Date of Patent: **\*\* Apr. 21, 1992**

[54] **AUTOMOBILE STEERING WHEEL LOCK**

4,103,524 8/1978 Mitchell et al. .... 70/209  
4,935,047 6/1990 Wu ..... 70/209

[76] Inventors: **Shwu-Meei Jan**, No. 7-2, Alley 13, Lane 54, Sec. 2, Hsing-Nan Road, Jung-Heh; **Hsien-Pao Chen**, No. 76, Lane 274, Jung-Jeng S. Road, Yung-Kang Shiang, both of Tainan Hsien, Taiwan

**FOREIGN PATENT DOCUMENTS**

2039840 8/1980 United Kingdom ..... 70/209 X

*Primary Examiner*—Brian N. Vinson  
*Attorney, Agent, or Firm*—Bacon & Thomas

[\*\*] Term: **14 Years**

[57] **CLAIM**

[21] Appl. No.: **593,633**

The ornamental design for an automobile steering wheel lock, as shown.

[22] Filed: **Oct. 5, 1990**

**DESCRIPTION**

[52] U.S. Cl. .... **D8/331**

[58] Field of Search ..... **D8/330-346;**  
70/207-211, 214-217, 225-227, 237-238,  
252-253

FIG. 1 is top, front, and left side perspective view of an automobile steering wheel lock showing our new design;

FIG. 2 is a front elevational view thereof;

FIG. 3 is a rear elevational view thereof;

FIG. 4 is a left side elevational view thereof;

FIG. 5 is a right side elevational view thereof;

FIG. 6 is a top plan view thereof; and,

FIG. 7 is a bottom plan view thereof.

[56] **References Cited**

**U.S. PATENT DOCUMENTS**

D. 289,491 4/1987 Johnson ..... D8/330  
D. 312,202 11/1990 Wang ..... D8/331 X

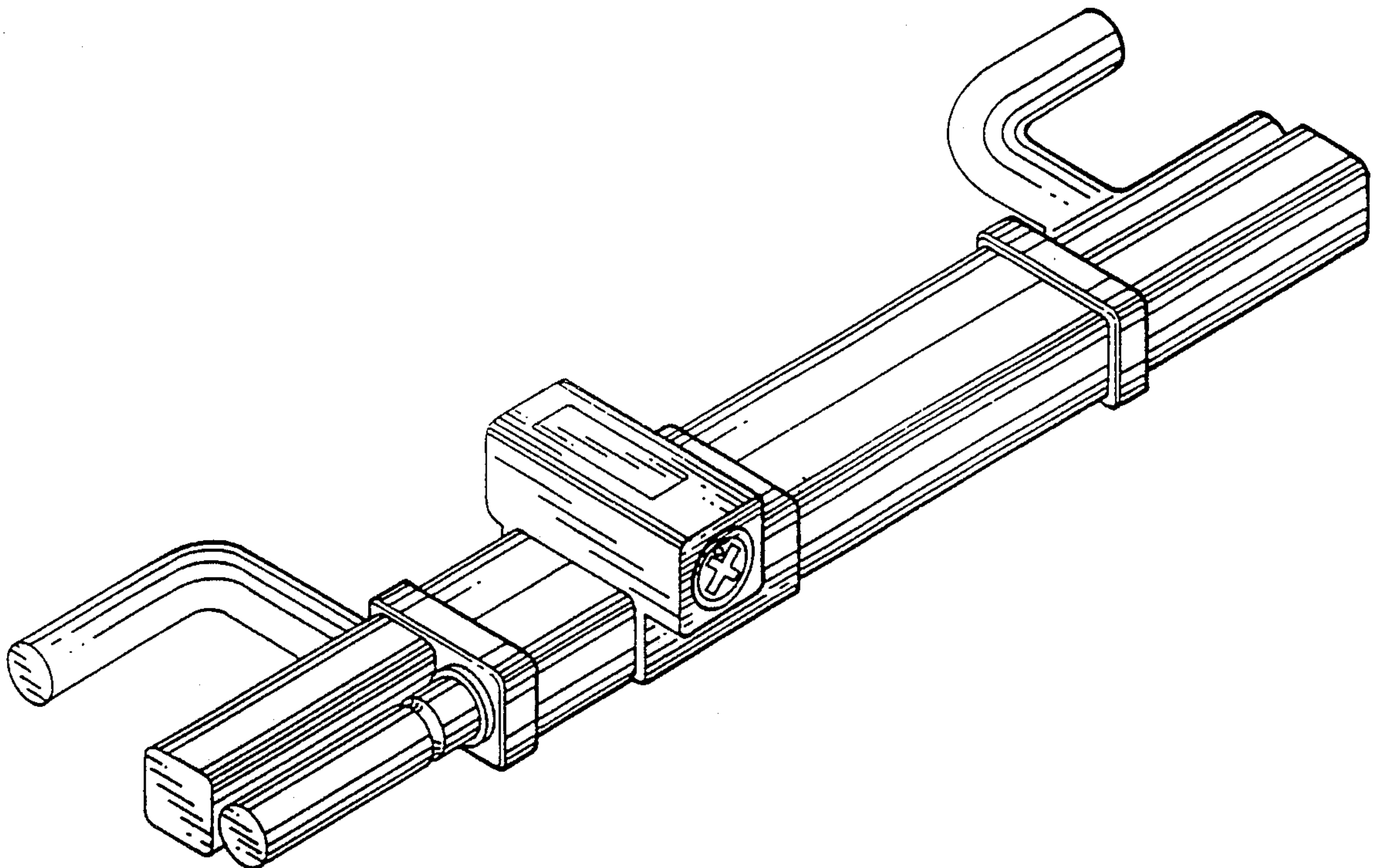

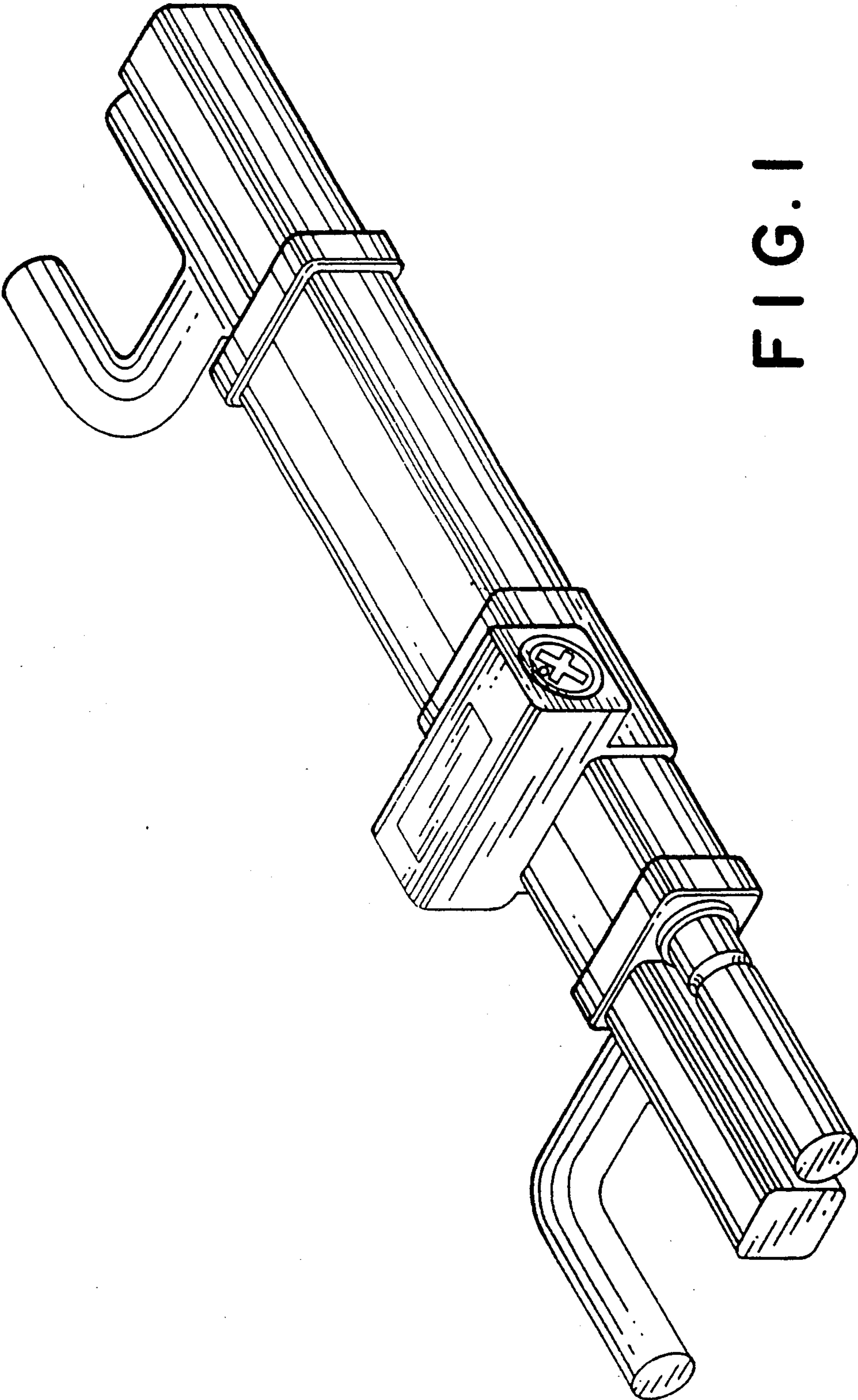

FIG. 1

FIG. 2

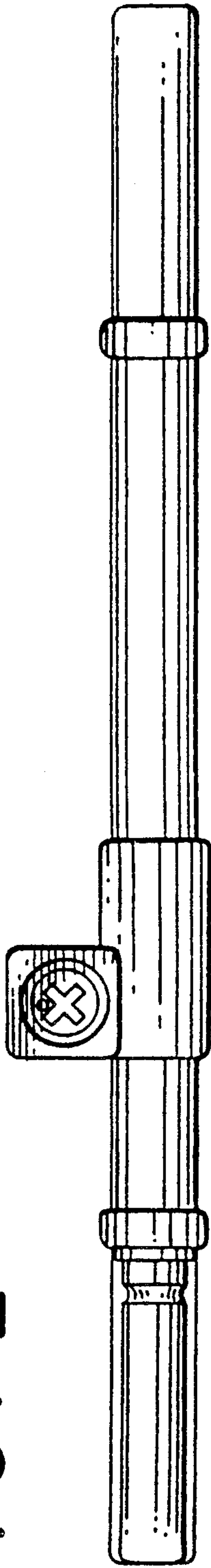

FIG. 3

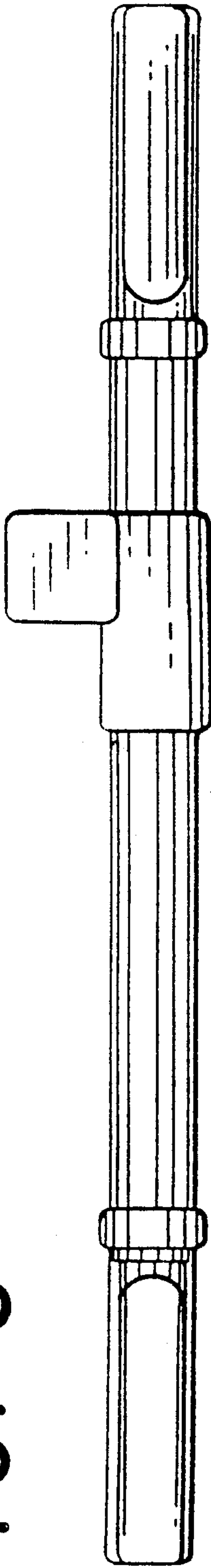

FIG. 4

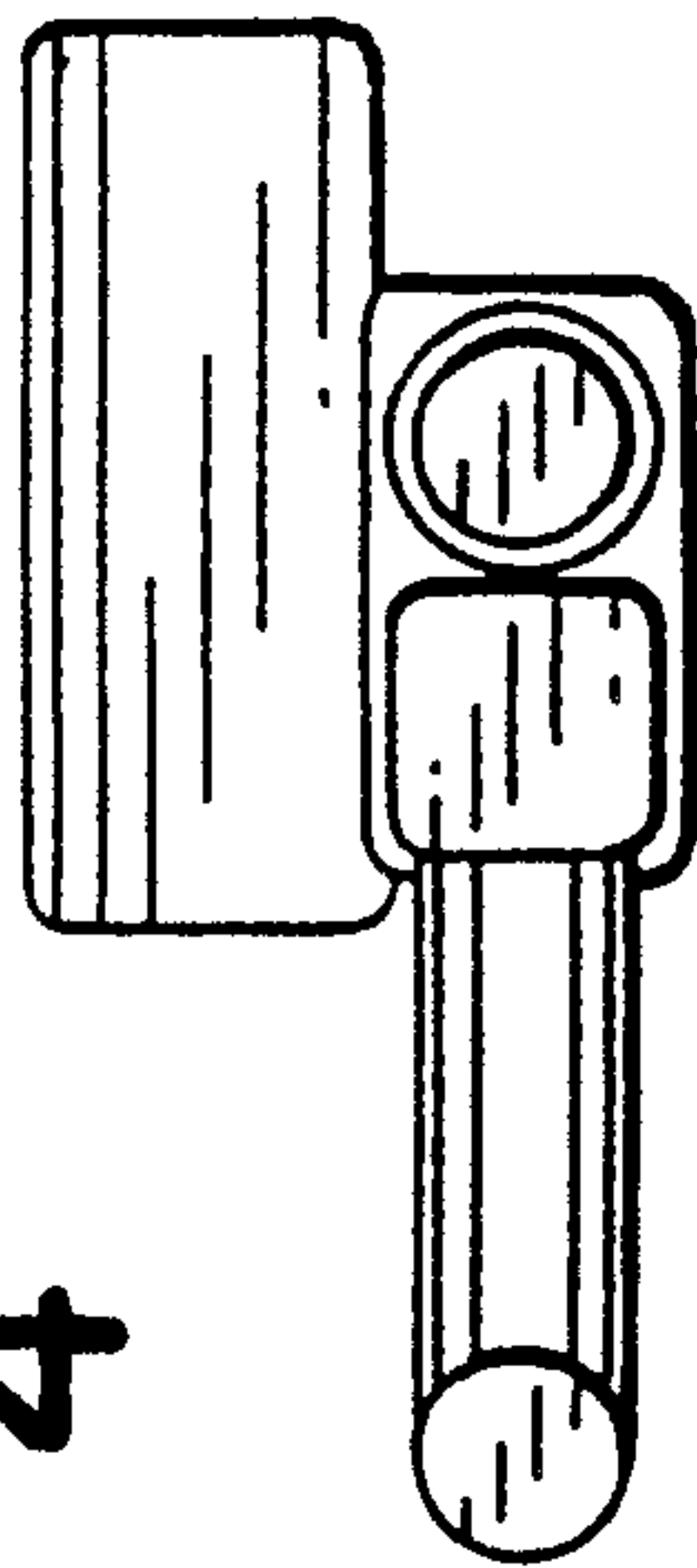
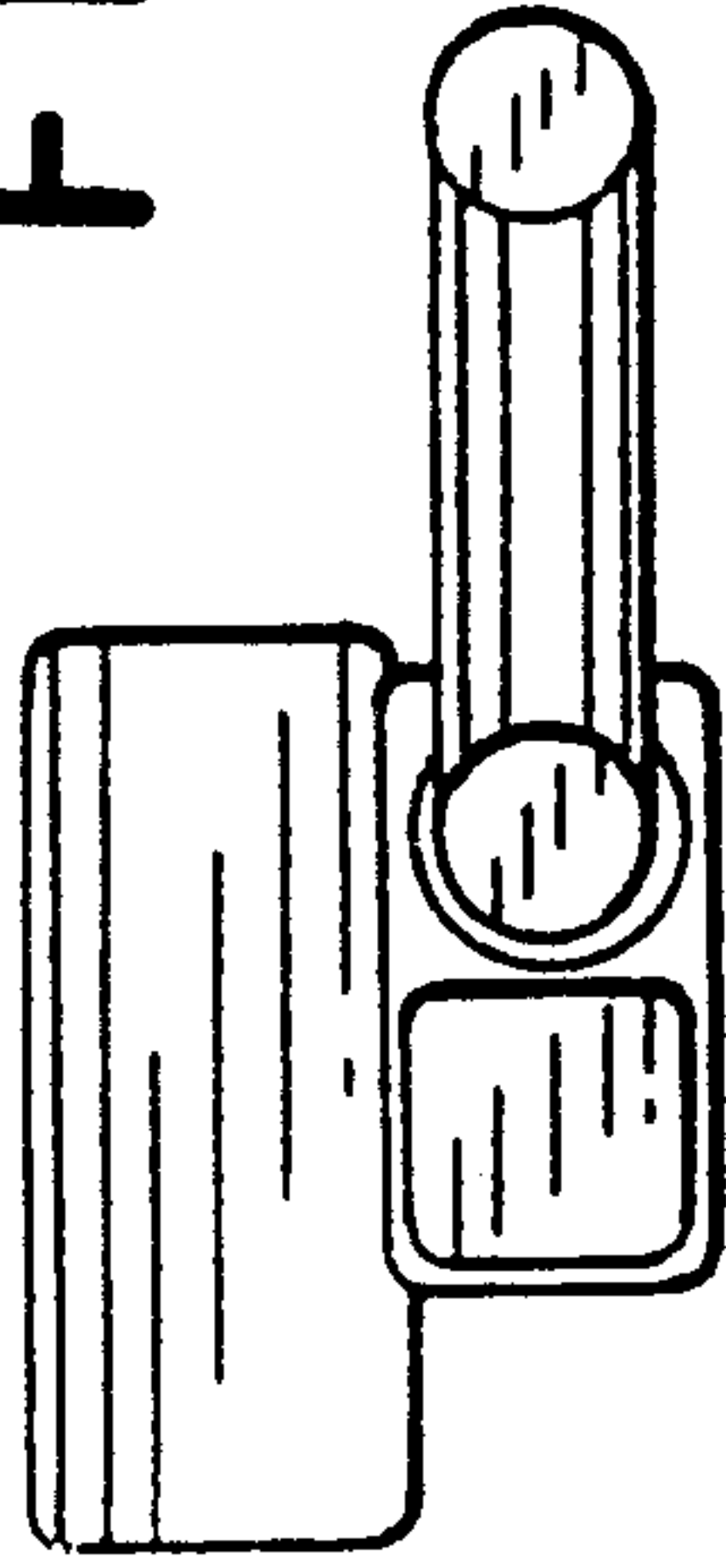

FIG. 5





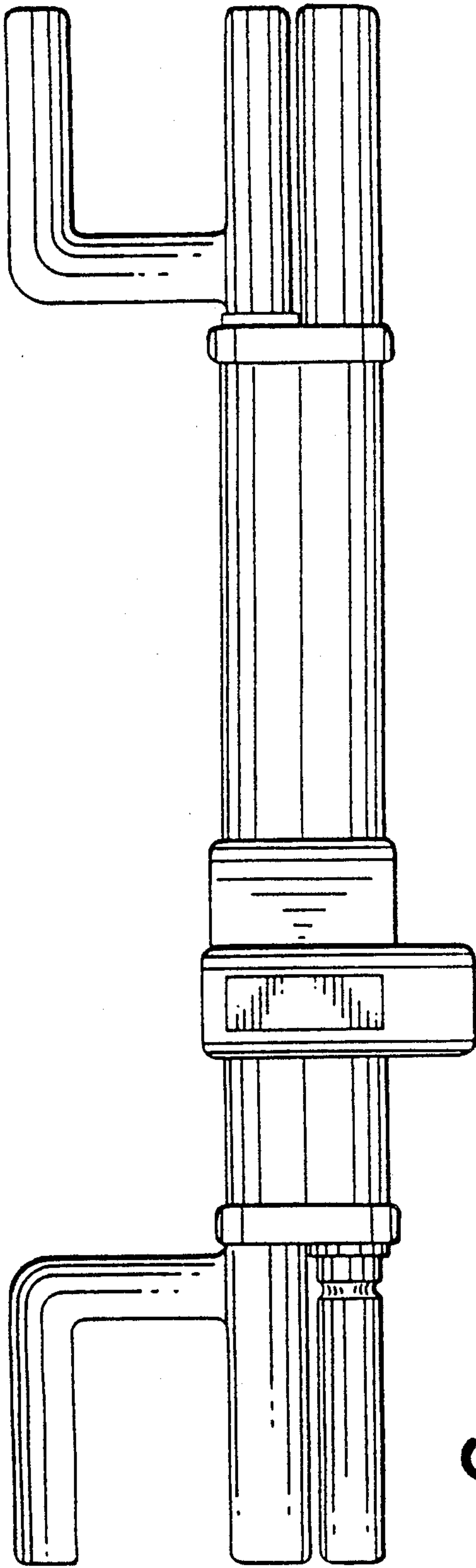

FIG. 6

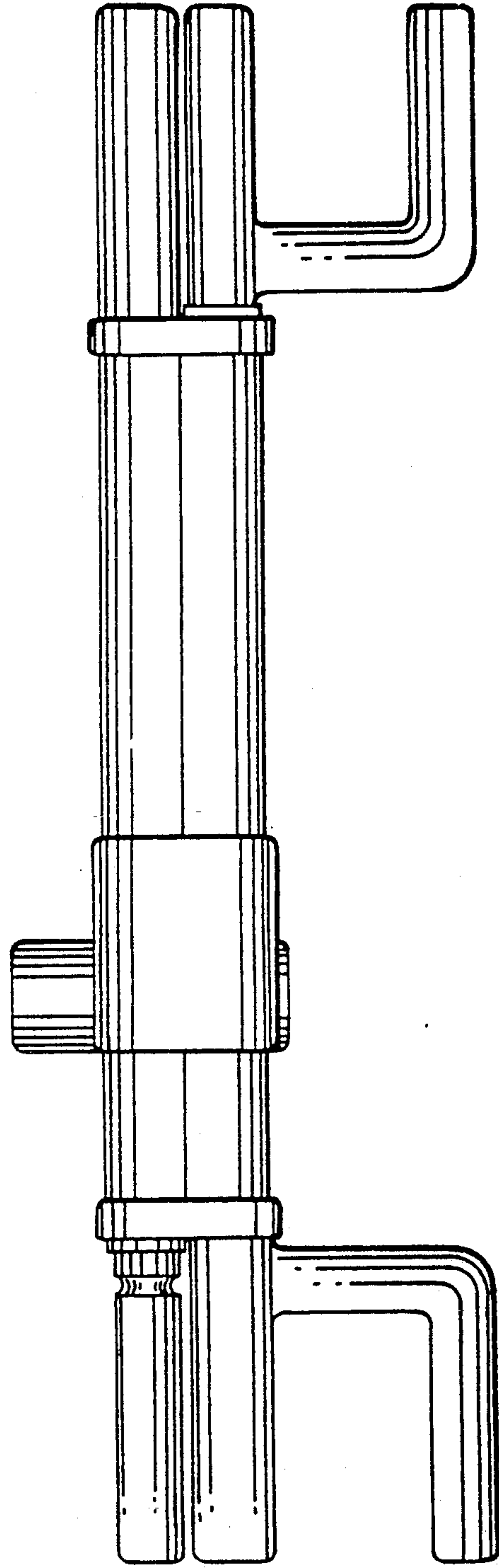

FIG. 7