



US00D325388S

# United States Patent [19]

[11] Patent Number: Des. 325,388

Saito

[45] Date of Patent: \*\* Apr. 14, 1992

[54] LEAD WIRE CUTTING MACHINE

[75] Inventor: Masayuki Saito, Maizuru, Japan

[73] Assignee: Nitto Seiko Co., Ltd., Kyoto, Japan

[\*\*] Term: 14 Years

[21] Appl. No.: 413,654

[22] Filed: Sep. 27, 1989

[30] Foreign Application Priority Data

Jun. 30, 1989 [JP] Japan ..... 1-24477

[52] U.S. Cl. .... D15/127

[58] Field of Search ..... D15/127, 129;  
140/123.6, 139, 140, 105; 83/580

[56] References Cited

U.S. PATENT DOCUMENTS

D. 292,100	9/1987	Goldsmith et al. ....	D15/127
3,396,758	8/1968	Hall .....	140/140 X
3,799,017	3/1974	Halligan .....	83/580 X
4,624,160	11/1986	Linker et al. ....	83/580 X
4,696,178	9/1987	Bihler et al. ....	140/105 X

Primary Examiner—Bruce W. Dunkins  
Assistant Examiner—Antoine D. Davis  
Attorney, Agent, or Firm—Armstrong, Nikaido,  
Marmelstein, Kubovcik and Murray

[57] CLAIM

The ornamental design for a lead wire cutting machine, as shown and described.

DESCRIPTION

FIG. 1 is a top, front and left side perspective view of a lead wire cutting machine showing my new design; FIG. 2 is a front elevational view; FIG. 3 is a rear elevational view; FIG. 4 is a left side elevational view; FIG. 5 is a right side elevational view; FIG. 6 is a top plan view; FIG. 7 is a bottom plan view; and, FIG. 8 is a top plan view thereof, shown in working condition. FIGS. 2-8 have been drawn to a reduced scale with respect to FIG. 1.

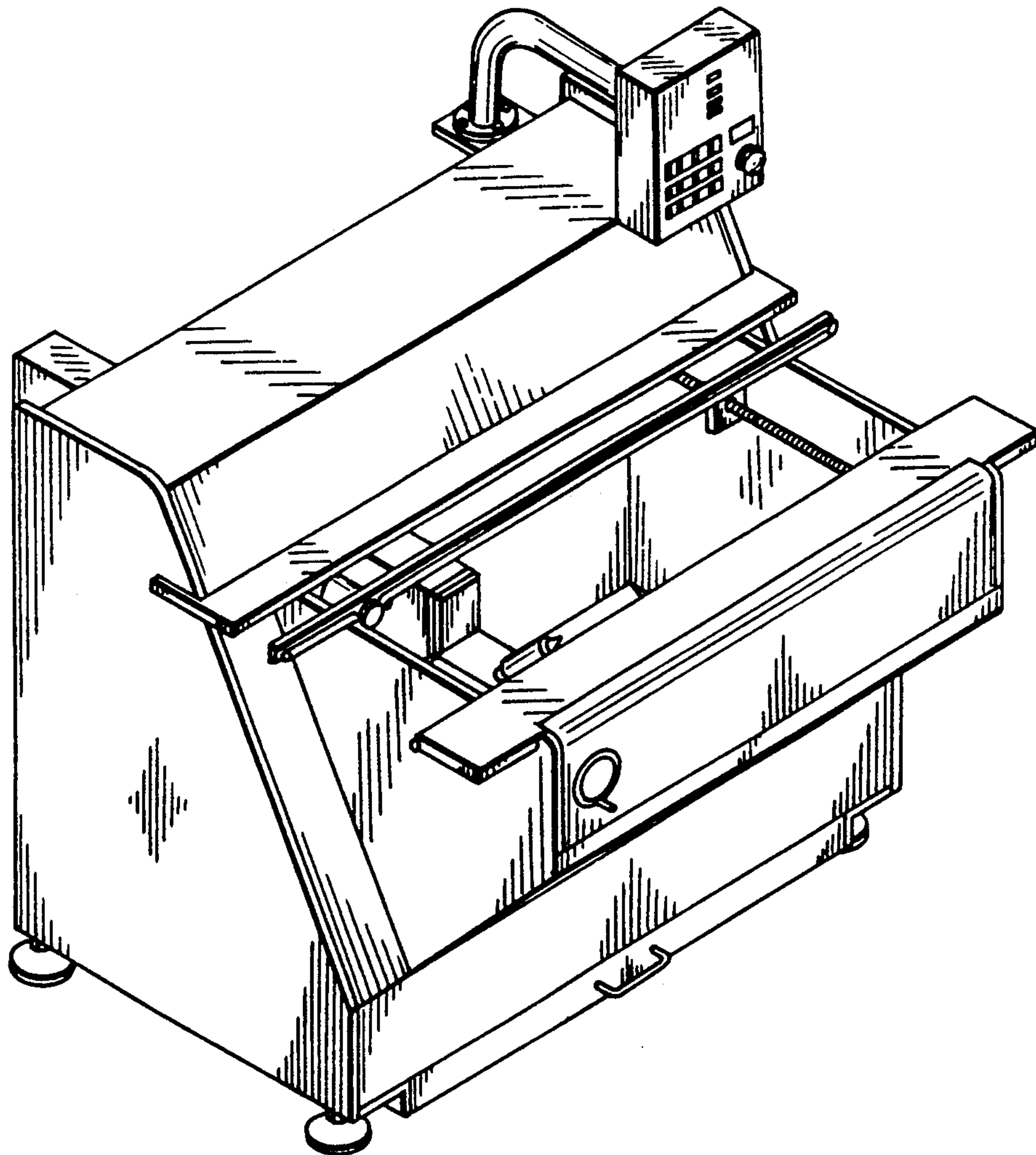

Fig. 1

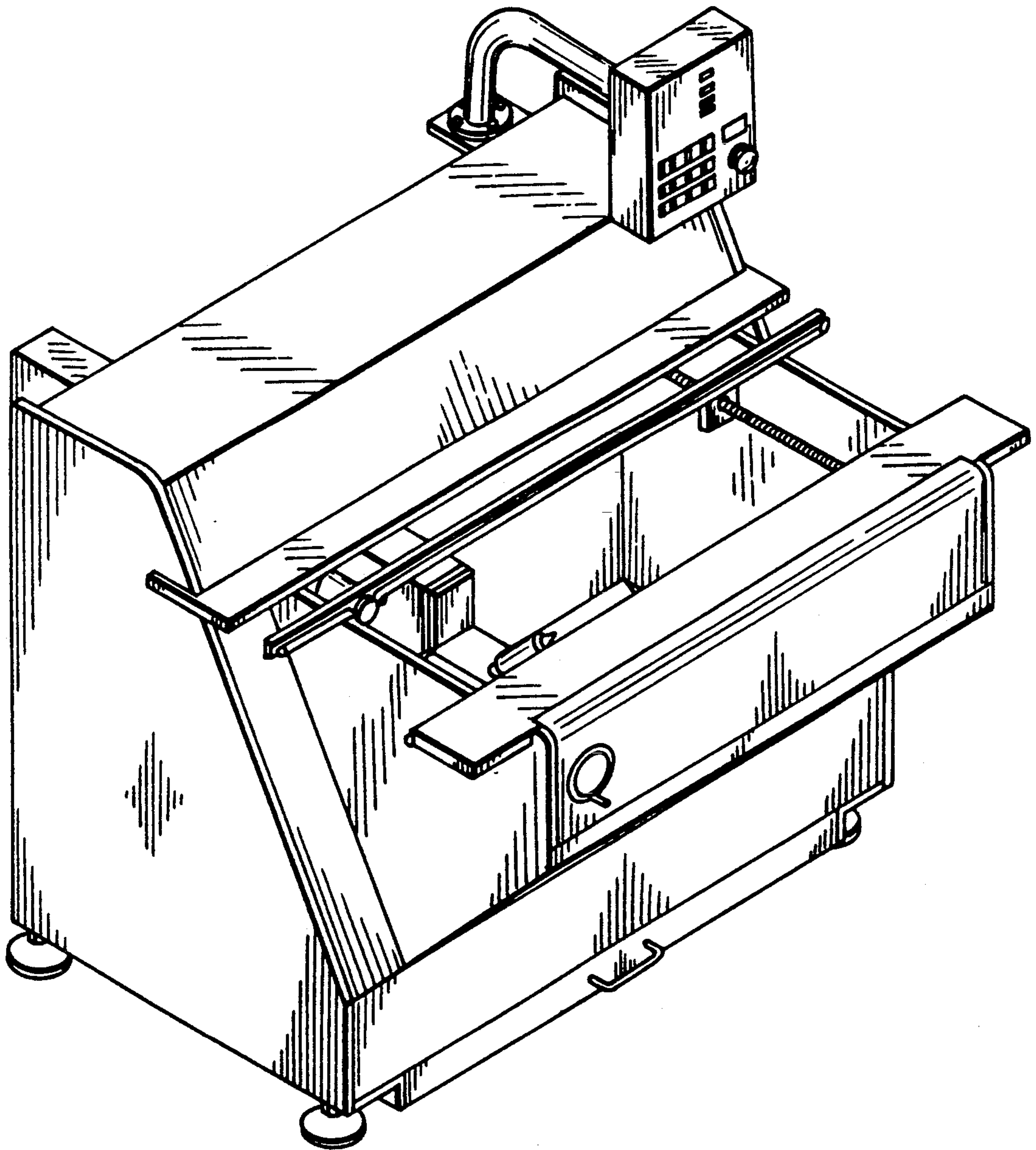

Fig. 2

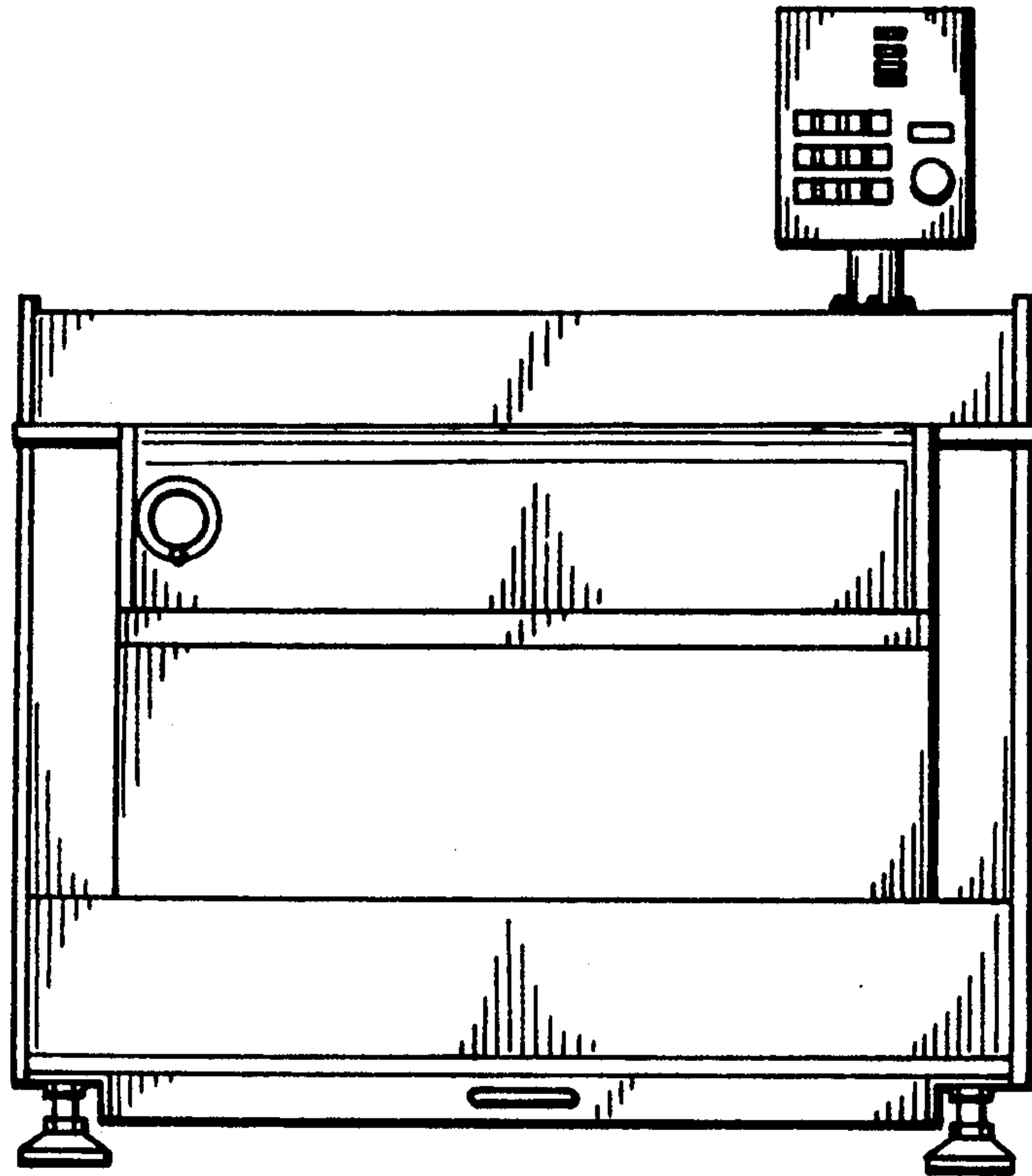

Fig. 3

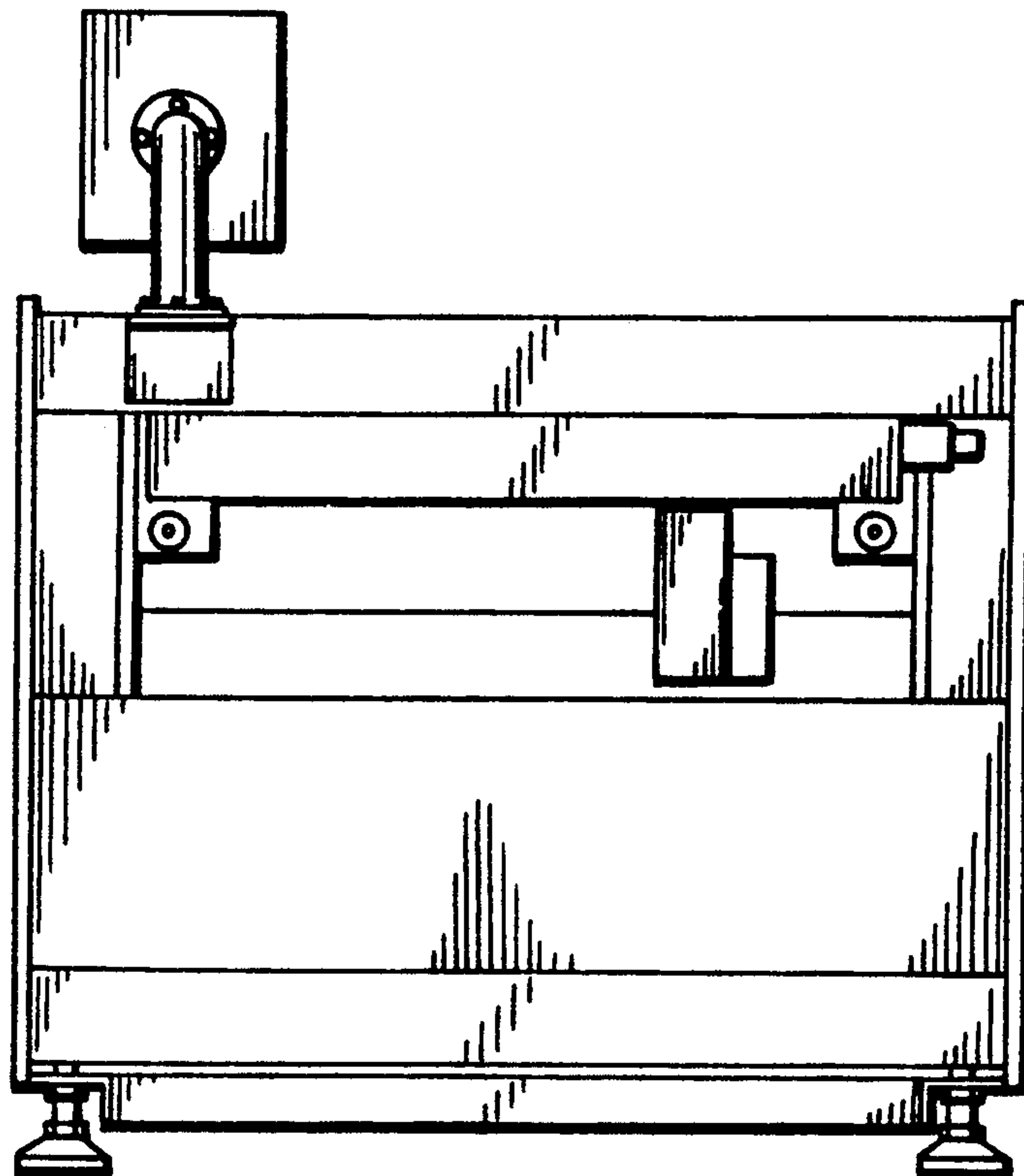

Fig. 4

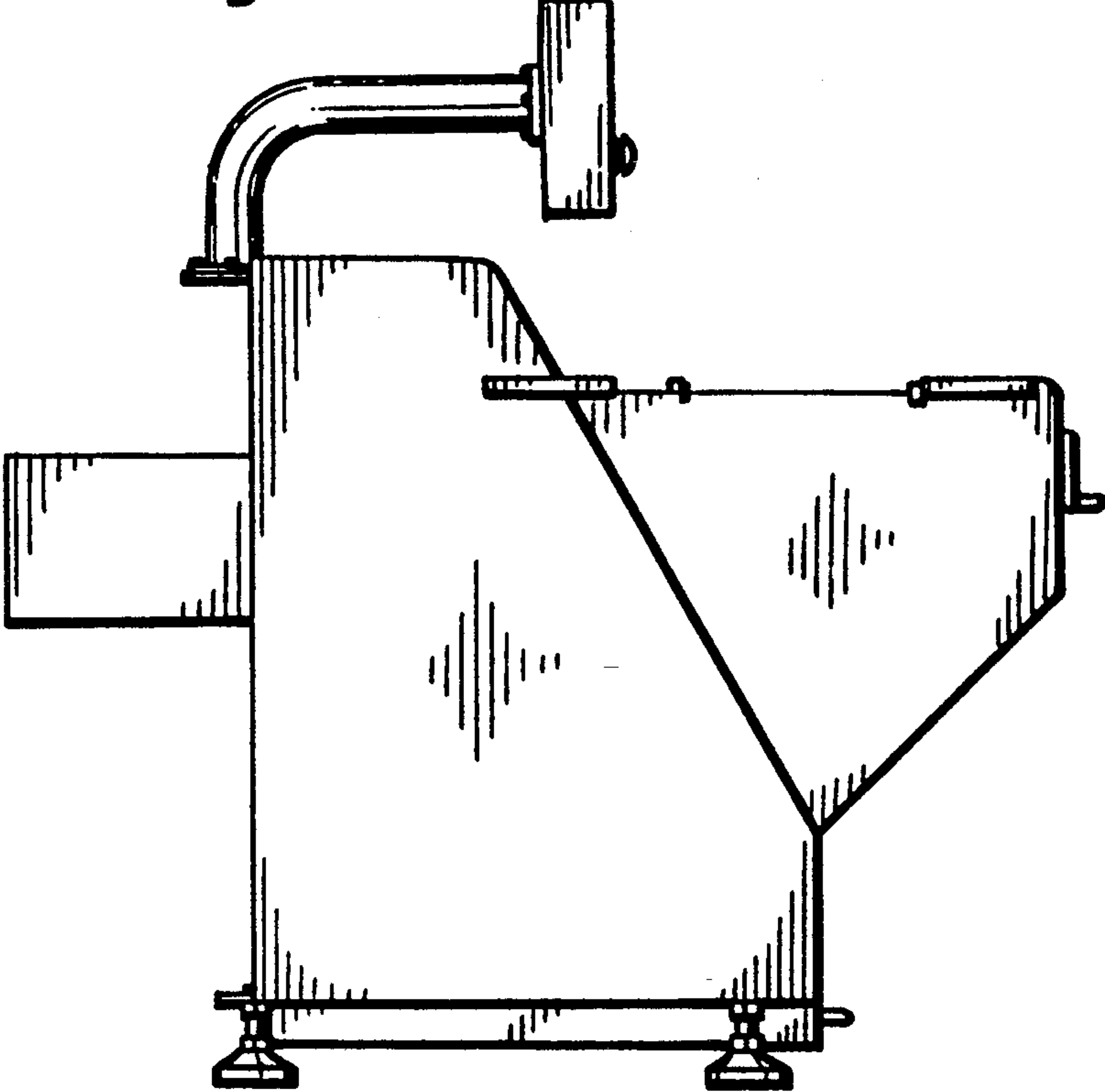

Fig. 5

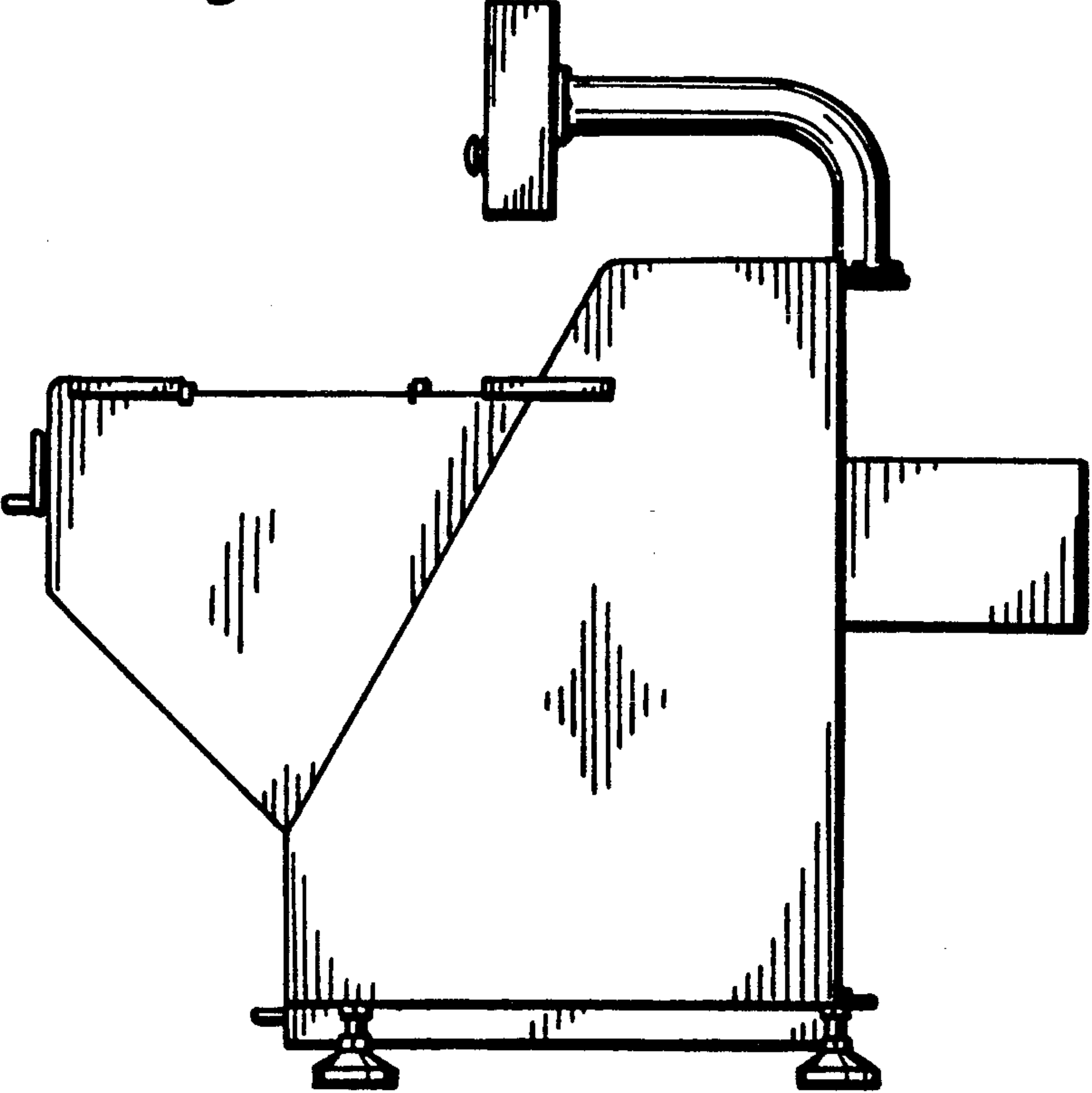



Fig. 6

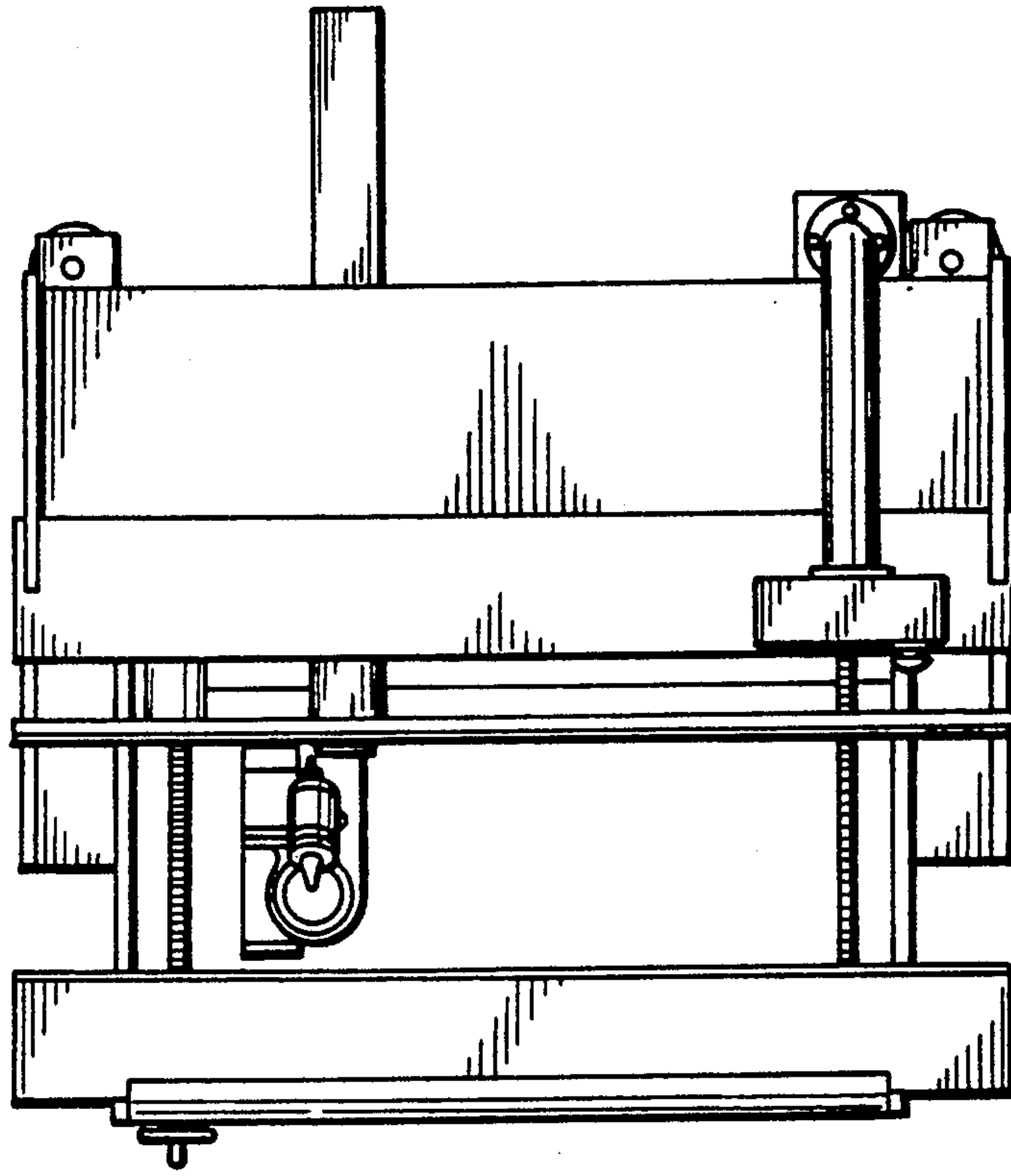

Fig. 7

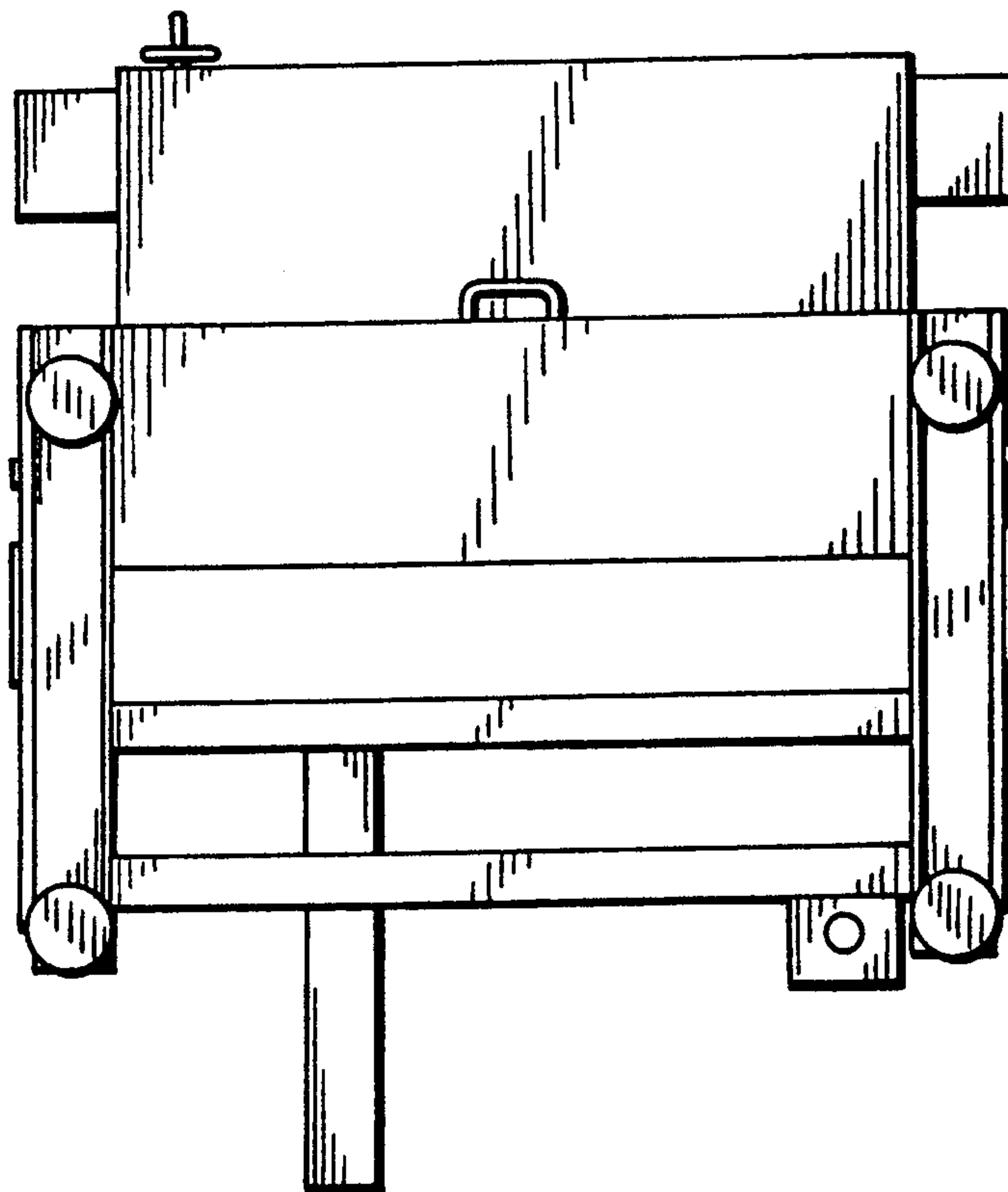

Fig. 8

