



US00D325361S

United States Patent [19]

[11] Patent Number: Des. 325,361

Gevert

[45] Date of Patent: ** Apr. 14, 1992

[54] MOTORCYCLE

[75] Inventor: Klaus V. Gevert, Munich, Fed. Rep. of Germany

[73] Assignee: Bayerische Motoren Werke Aktiengesellschaft, Fed. Rep. of Germany

[**] Term: 14 Years

[21] Appl. No.: 311,572

[22] Filed: Feb. 15, 1989

[30] Foreign Application Priority Data

Aug. 16, 1988 [DE] Fed. Rep. of Germany 8801064

[52] U.S. Cl. D12/110; D12/110; 180/219

[58] Field of Search D12/110; 180/219

[56] References Cited

U.S. PATENT DOCUMENTS

D. 275,469	9/1984	Morioka et al.	D12/110
D. 283,605	4/1986	Abe	D12/110
D. 285,185	8/1986	Morioka et al.	D12/110
4,709,774	12/1987	Saito et al.	D12/110

OTHER PUBLICATIONS

Cycle World, Dec. 1988, p. 49, BMW R100GS Paris-Dakar Motorcycle.

Cycle World, Jul. 1988, p. 33, BMW R100GS Motorcycle.

Primary Examiner—James M. Gandy

Assistant Examiner—Melody Brown

Attorney, Agent, or Firm—Evenson, Wands, Edwards, Lenahan & McKeown

[57] CLAIM

The ornamental design for a motorcycle, as shown.

DESCRIPTION

FIG. 1 is a front elevation view of a motorcycle showing my new design;

FIG. 2 is a rear elevation view thereof;

FIG. 3 is a left side elevation view thereof;

FIG. 4 is a right side elevation view thereof;

FIG. 5 is a top plan view thereof;

FIG. 6 is a rear and right side perspective view thereof, with the gas tank lid in open condition; and,

FIG. 7 is a front and right side perspective view thereof, with the gas tank lid in open condition.

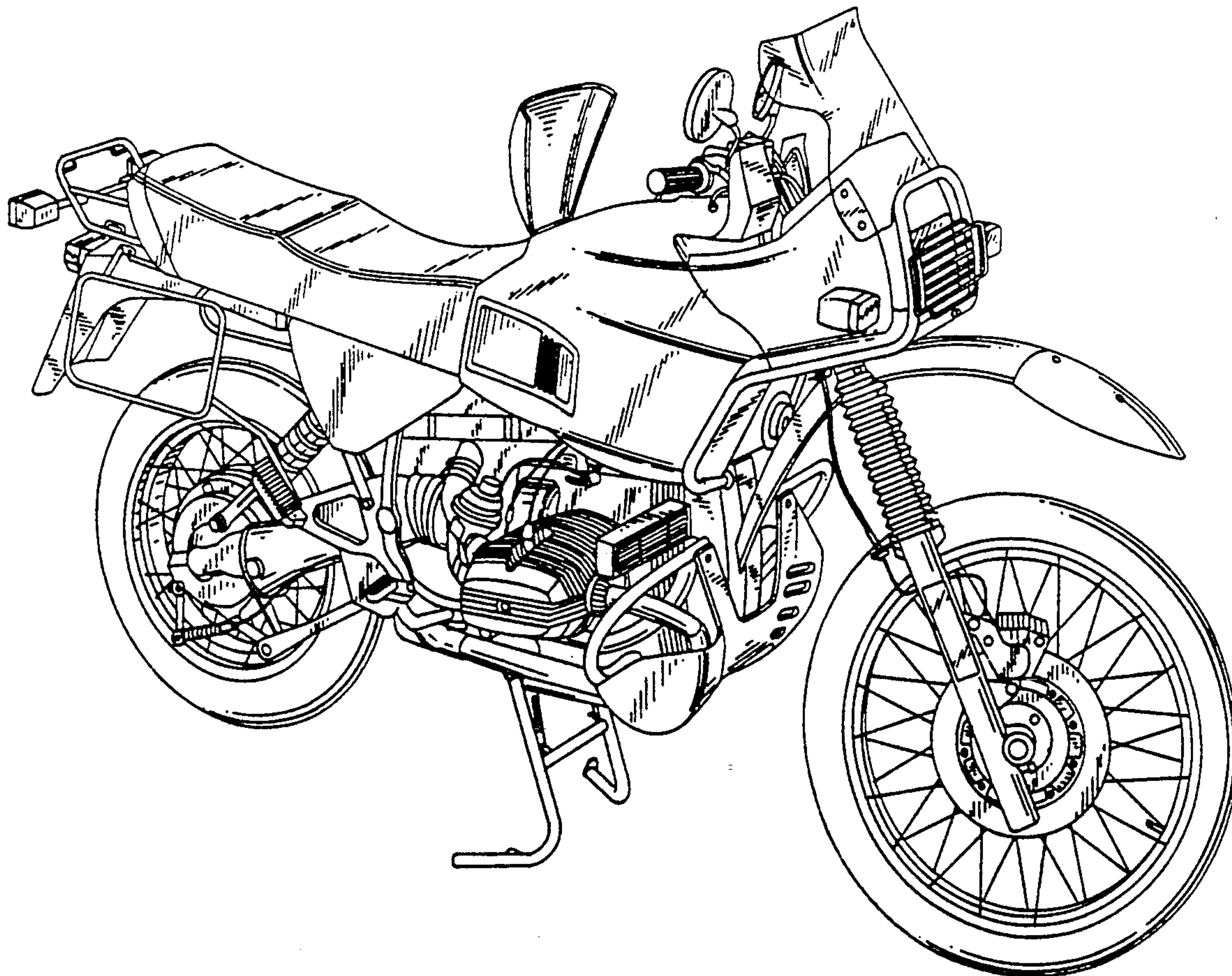

FIG. 1

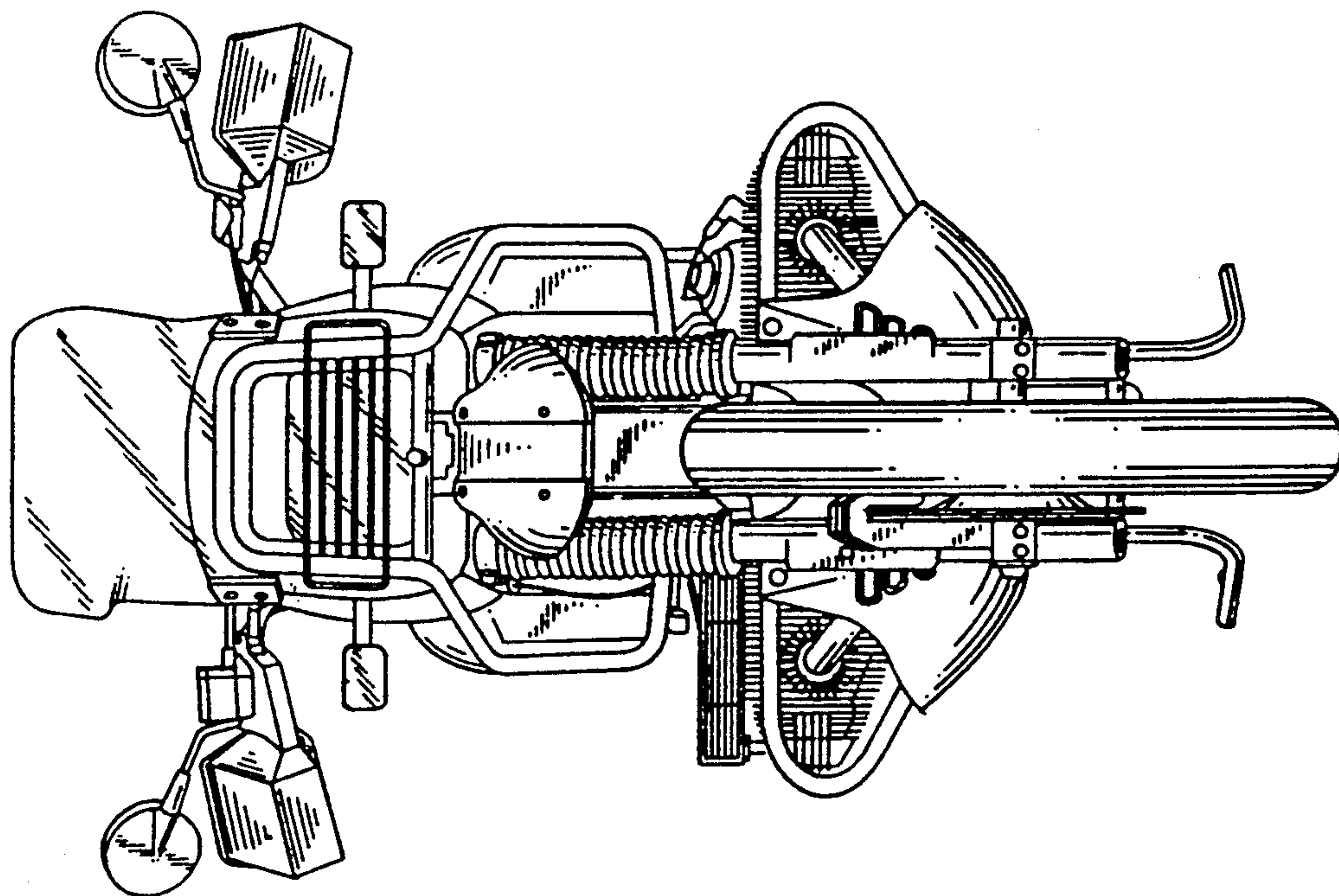
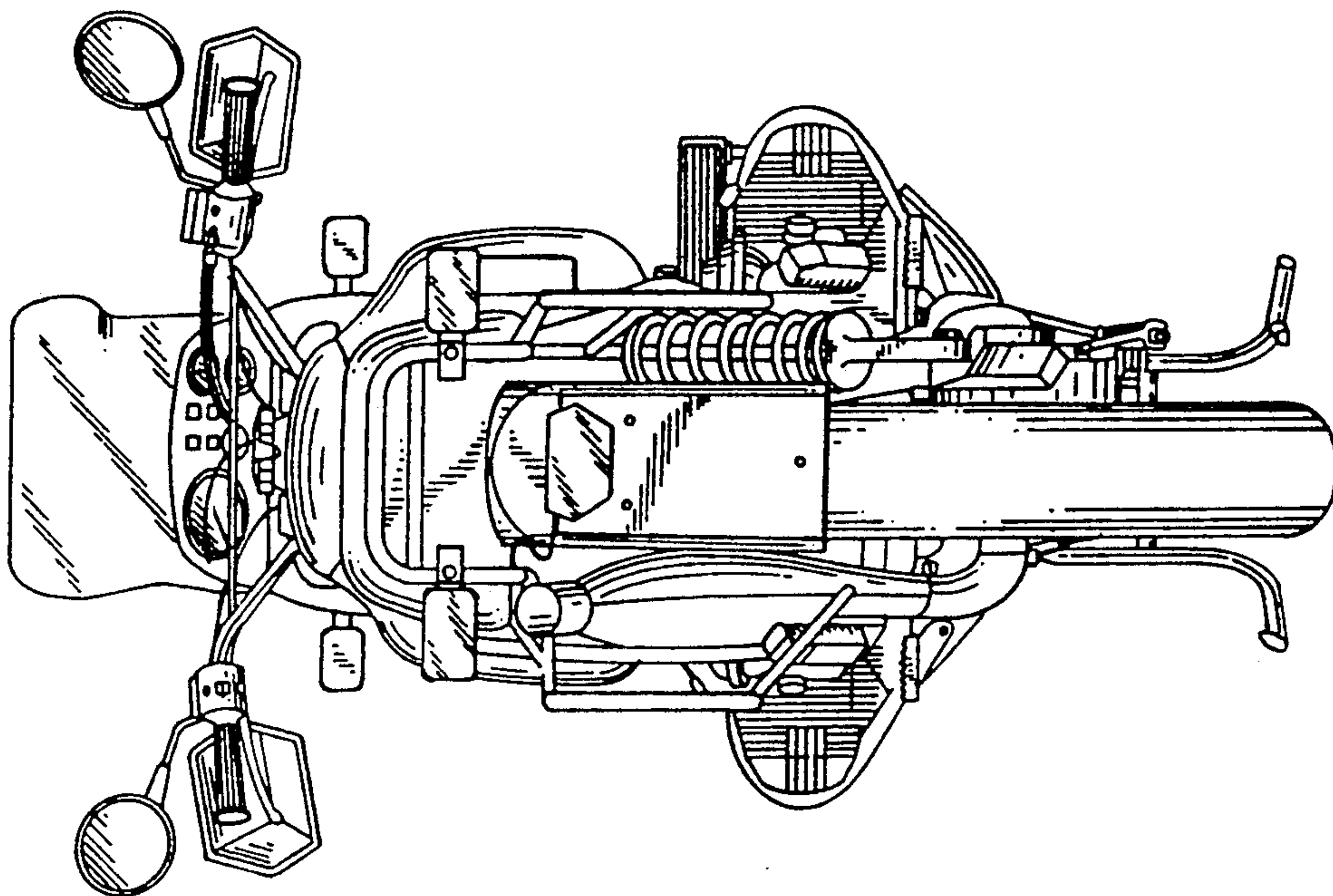

FIG. 2



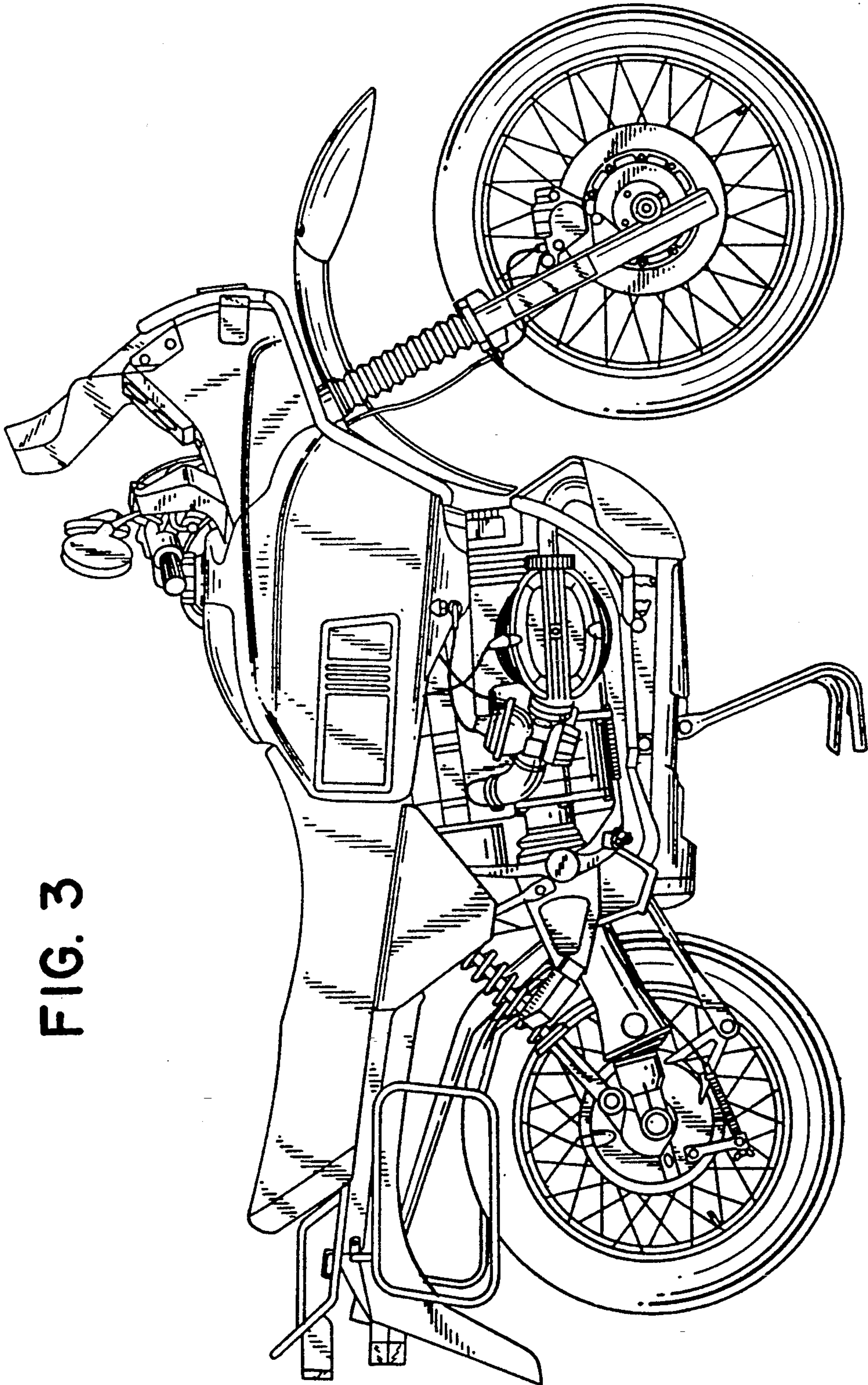

FIG. 3

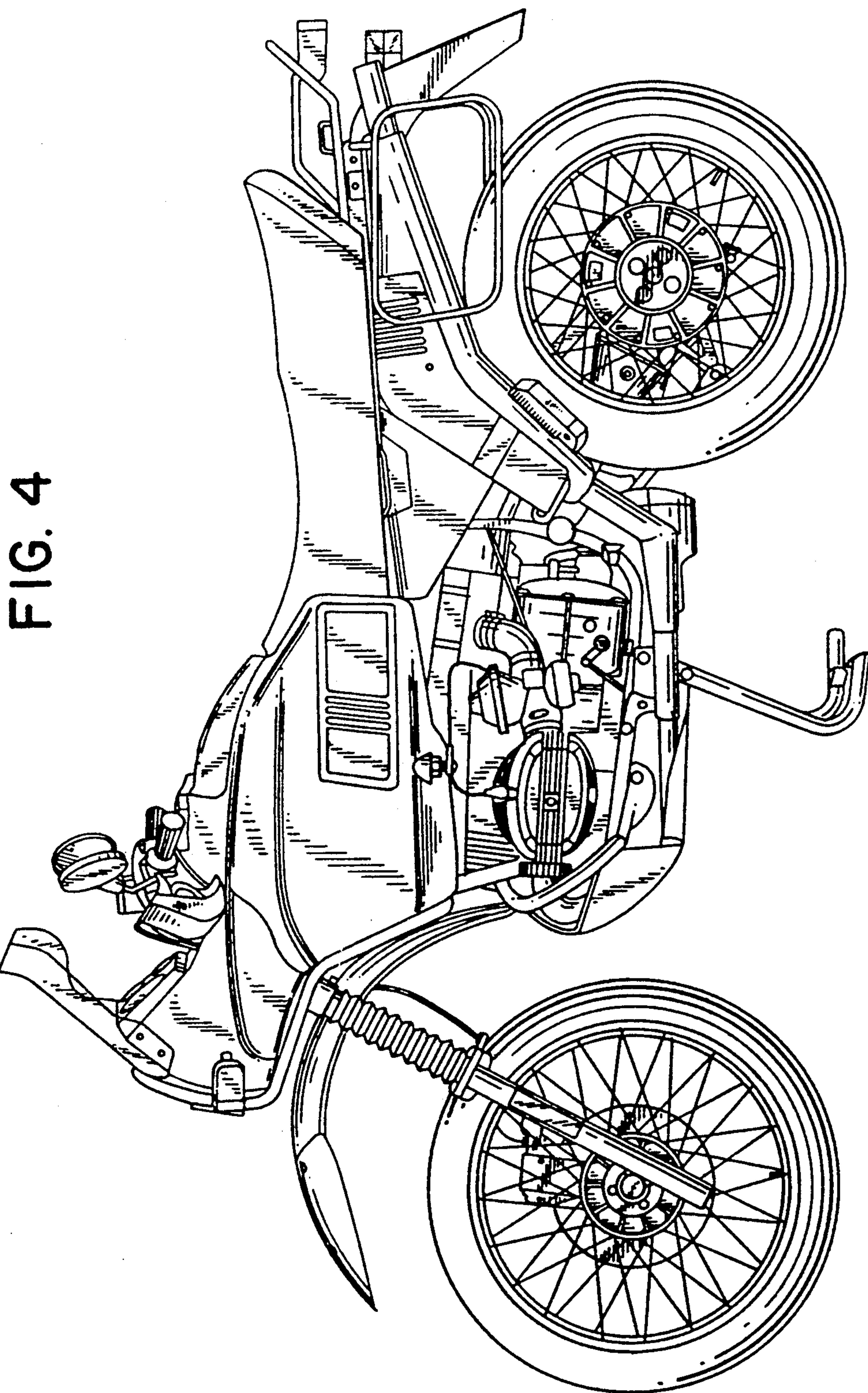

FIG. 4

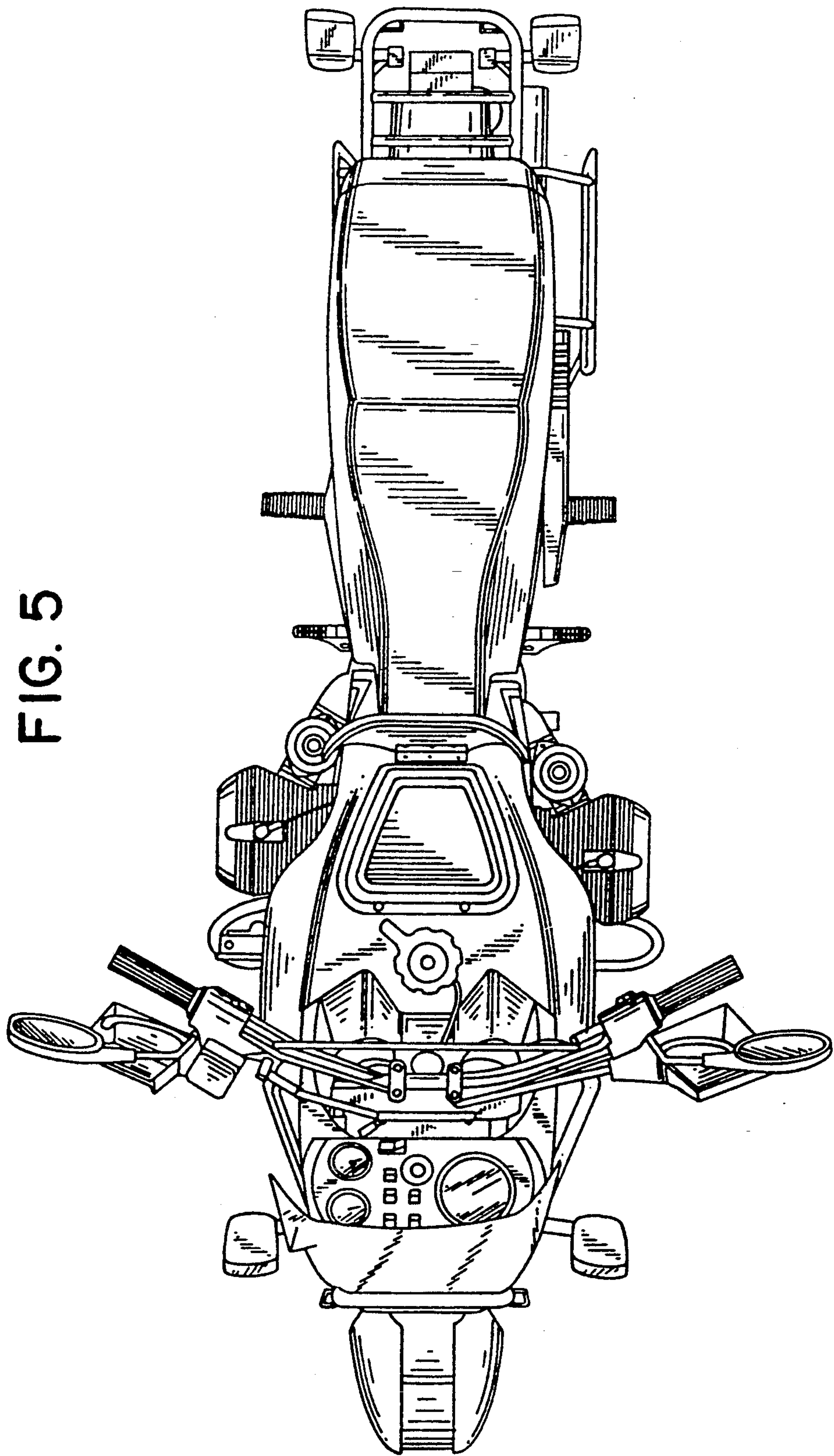

FIG. 5

FIG. 6

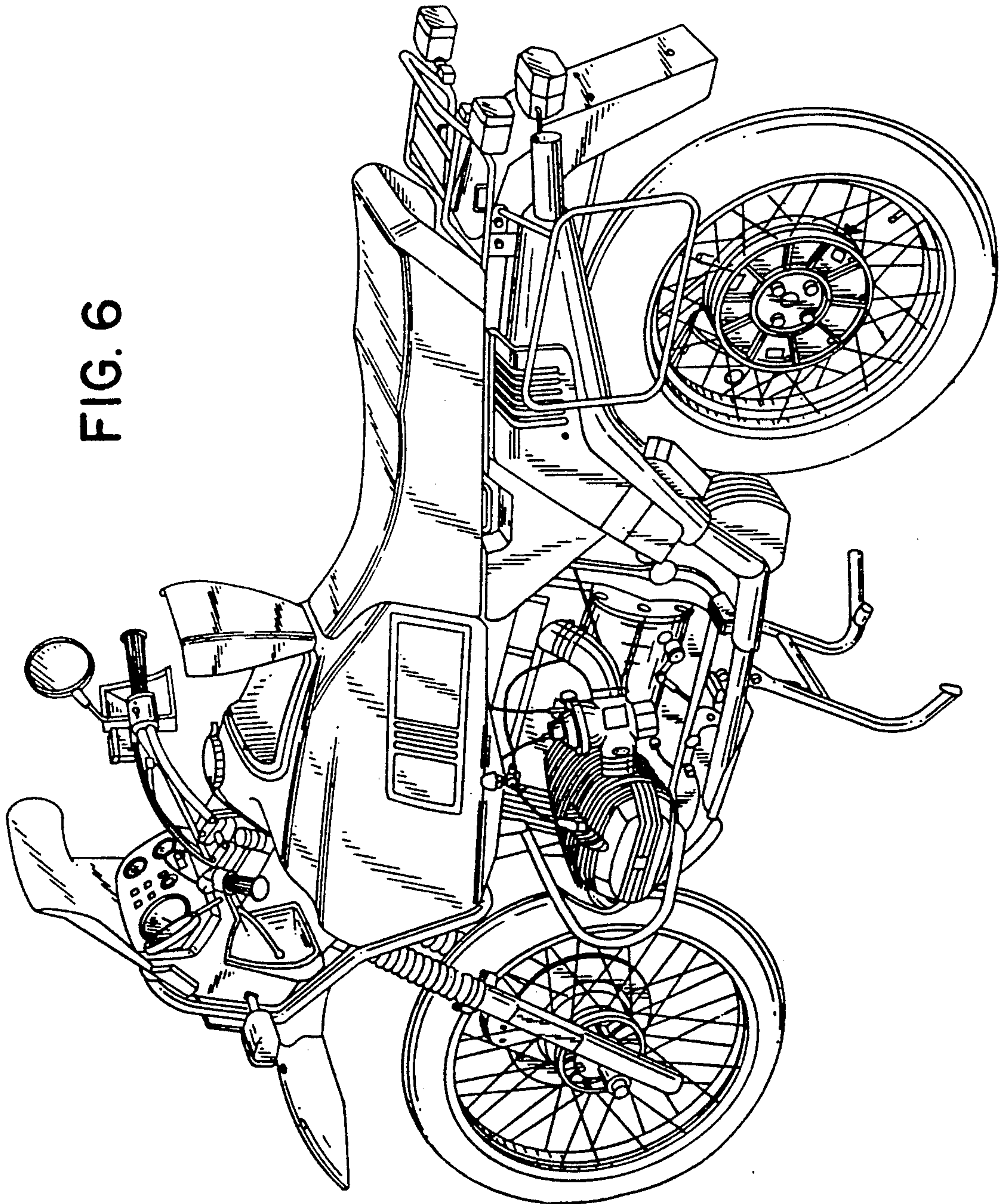

FIG. 7

