



US00D325360S

United States Patent [19]

[11] Patent Number: **Des. 325,360**

Saito et al.

[45] Date of Patent: **** Apr. 14, 1992**

[54] **FOUR WHEEL VEHICLE**

[75] Inventors: **Kazuhiko Saito**, Rancho Palos Verdes; **Yutaka Kawasaki**, Redondo Beach, both of Calif.

[73] Assignee: **Honda Giken Kogyo Kabushiki Kaisha**, Tokyo, Japan

[**] Term: **14 Years**

[21] Appl. No.: **337,123**

[22] Filed: **Apr. 12, 1989**

[52] U.S. Cl. **D12/107**

[58] Field of Search **D12/107; 180/233, 311, 180/312, 215**

[56] **References Cited**

U.S. PATENT DOCUMENTS

D. 289,986	5/1987	Ooba et al.	D12/107
D. 293,324	1/1989	Oba et al.	D12/107
D. 293,900	1/1988	Murakami	D12/107
D. 298,811	12/1988	Morita	D12/107
D. 299,707	2/1989	Makita et al.	D12/107
4,573,550	3/1986	Inomata et al.	180/215

Primary Examiner—James M. Gandy
Assistant Examiner—Melody Brown
Attorney, Agent, or Firm—Irving M. Weiner; Joseph P. Carrier; Pamela S. Burt

[57] **CLAIM**

The ornamental design for a four wheel vehicle, as shown.

DESCRIPTION

FIG. 1 is a perspective view of a four wheel vehicle showing our new design from the rear;
FIG. 2 is a left side elevational view thereof;
FIG. 3 is a right side elevational view thereof;
FIG. 4 is a front elevational view thereof;
FIG. 5 is a rear elevational view thereof;
FIG. 6 is a top plan view thereof;
FIG. 7 is a bottom view thereof;
FIG. 8 is a left side elevational view thereof, with rear upper lid removed for convenience of illustration;
FIG. 9 is a right side elevational view of FIG. 8;
FIG. 10 is a front elevational view of FIG. 8;
FIG. 11 is a rear elevational view of FIG. 8;
FIG. 12 is a top plan view of FIG. 8; and,
FIG. 13 is a bottom plan view of FIG. 8.

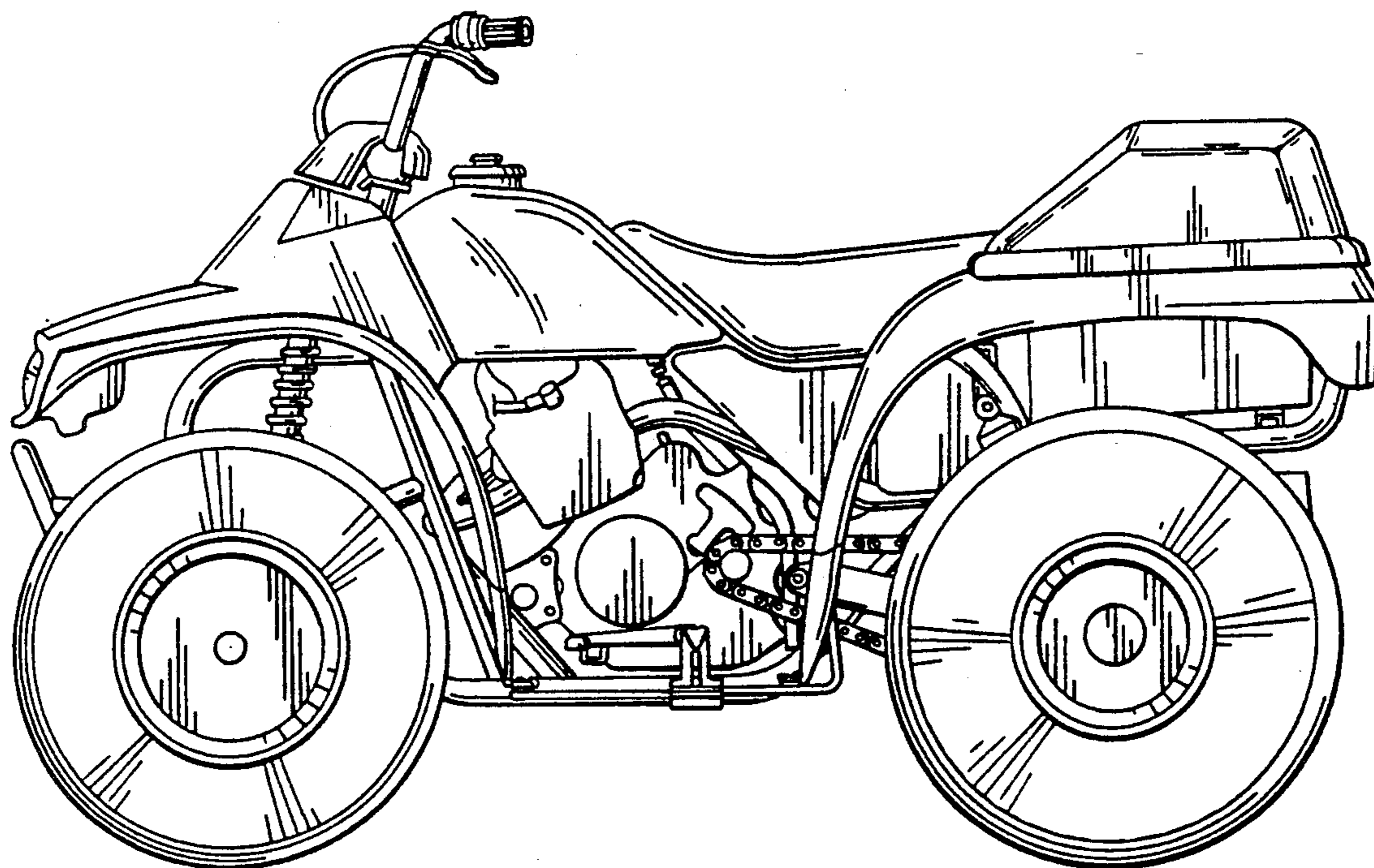

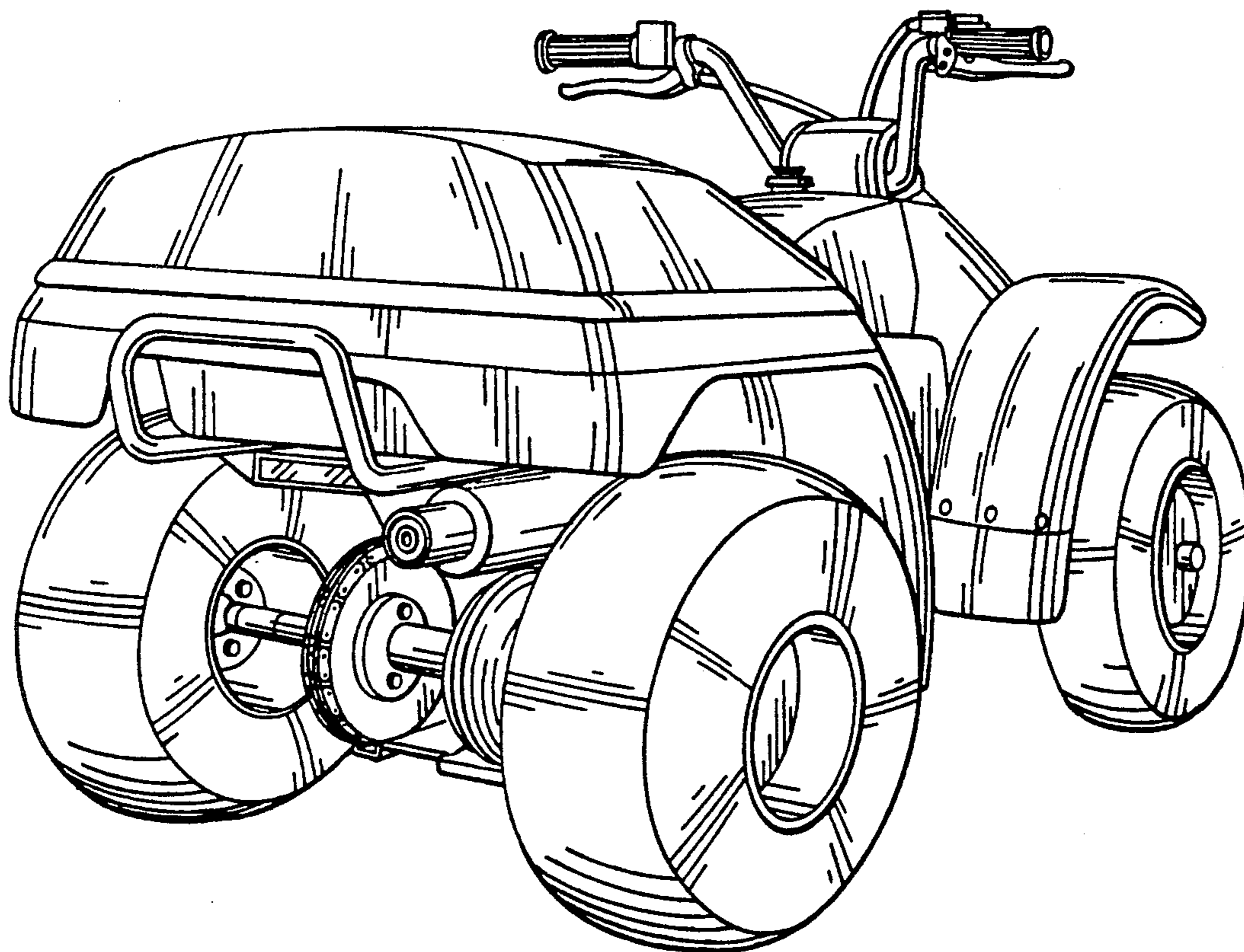

Fig. 1

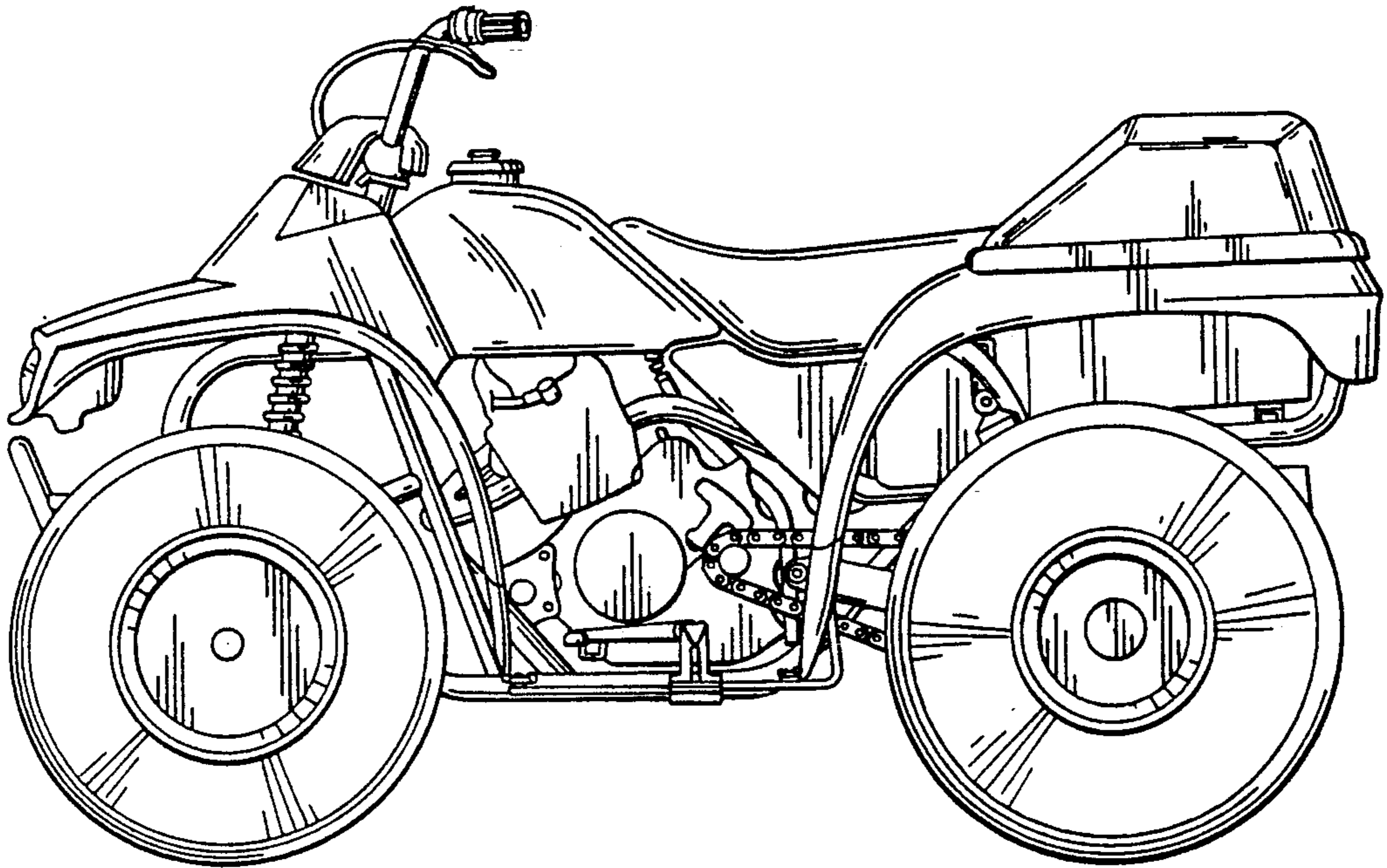

Fig. 2

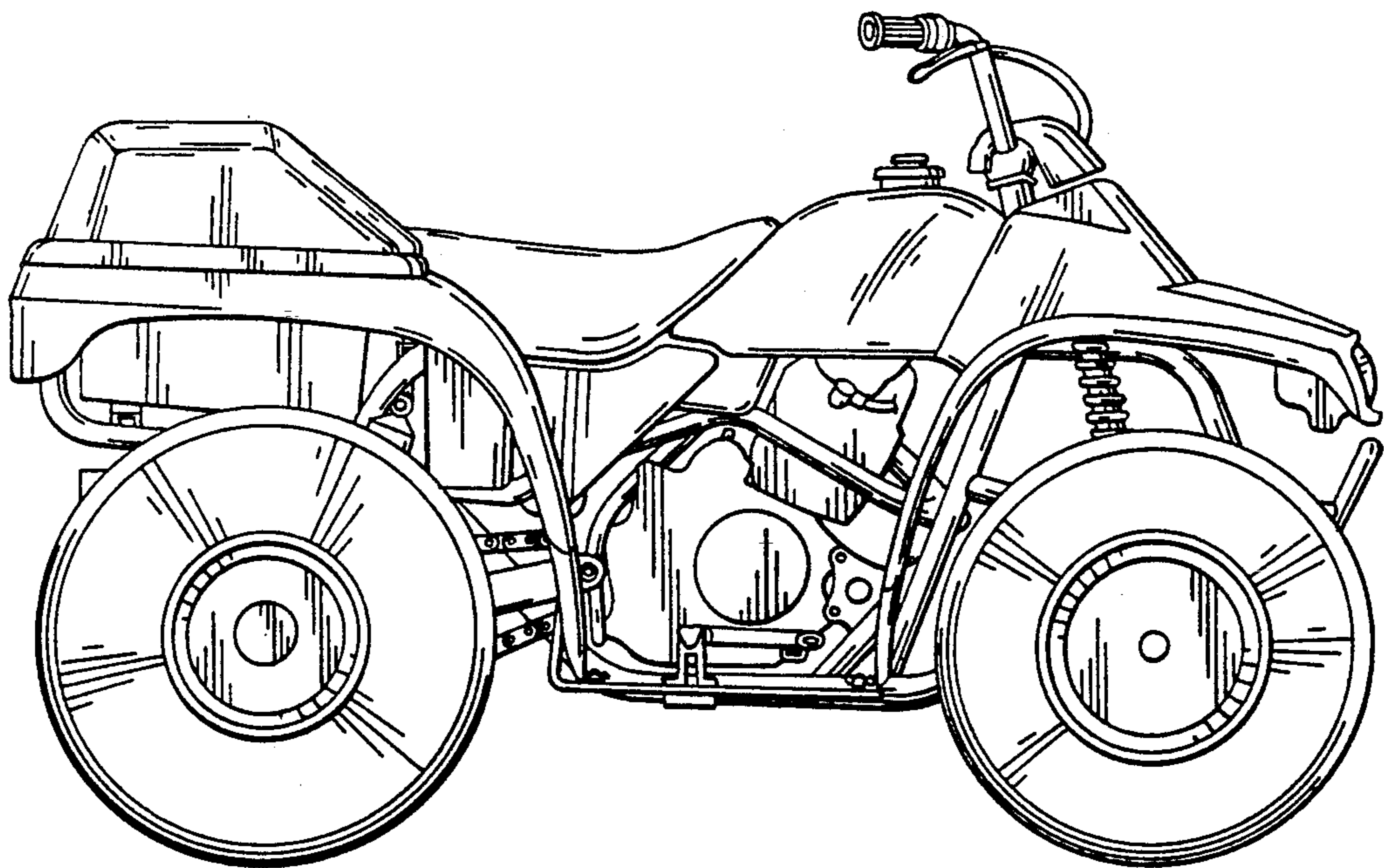

Fig. 3

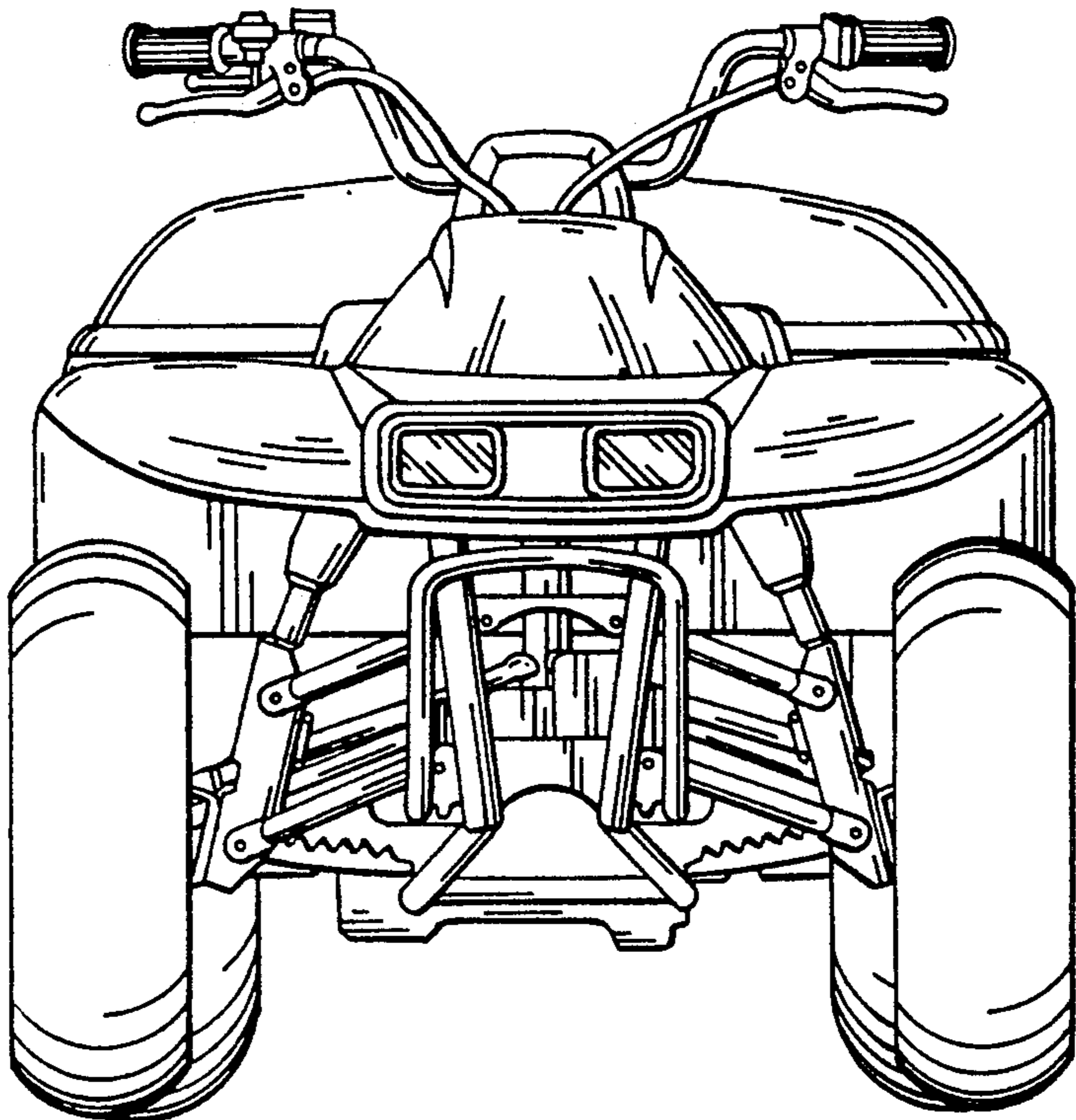

Fig. 4

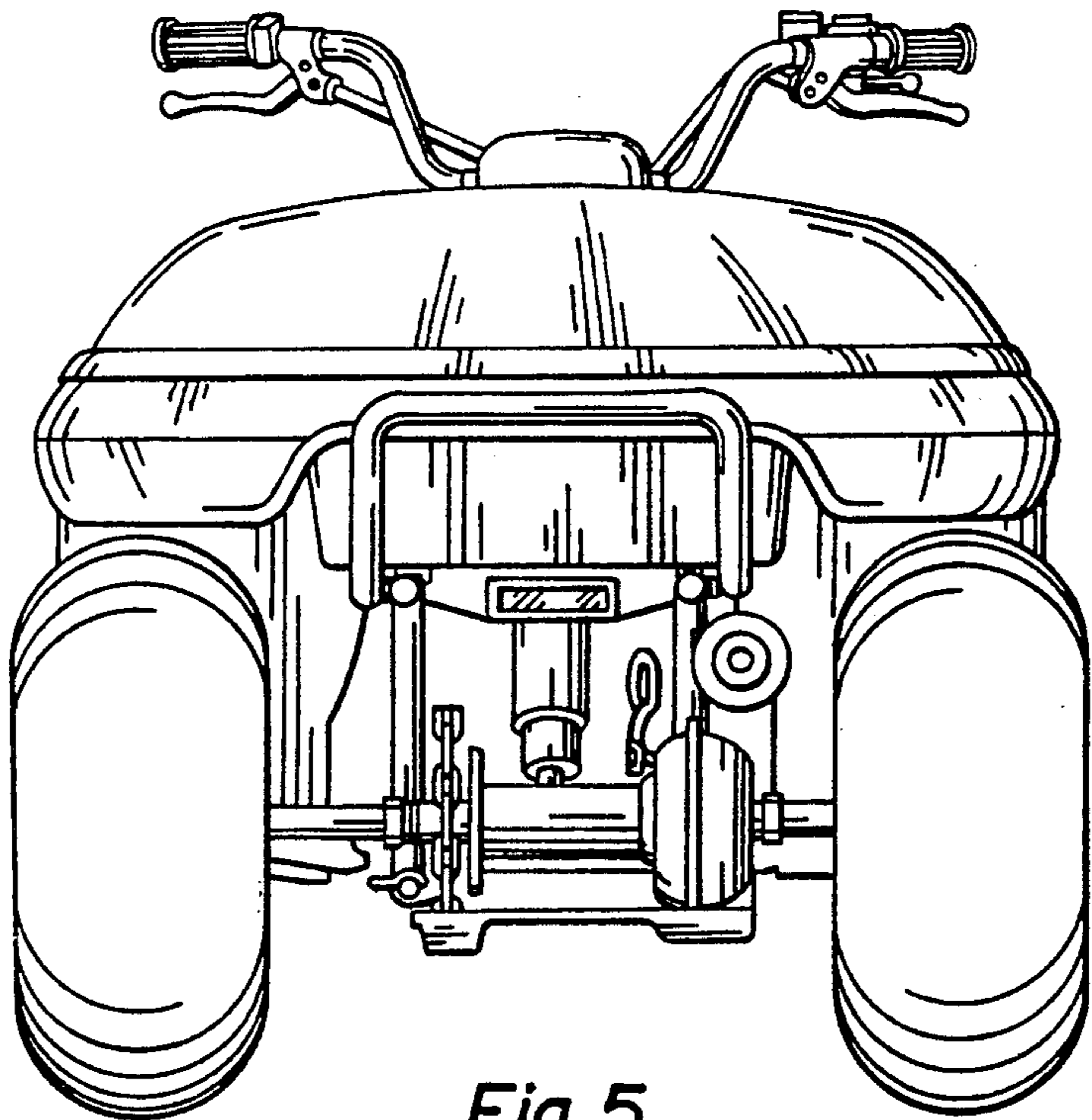

Fig. 5

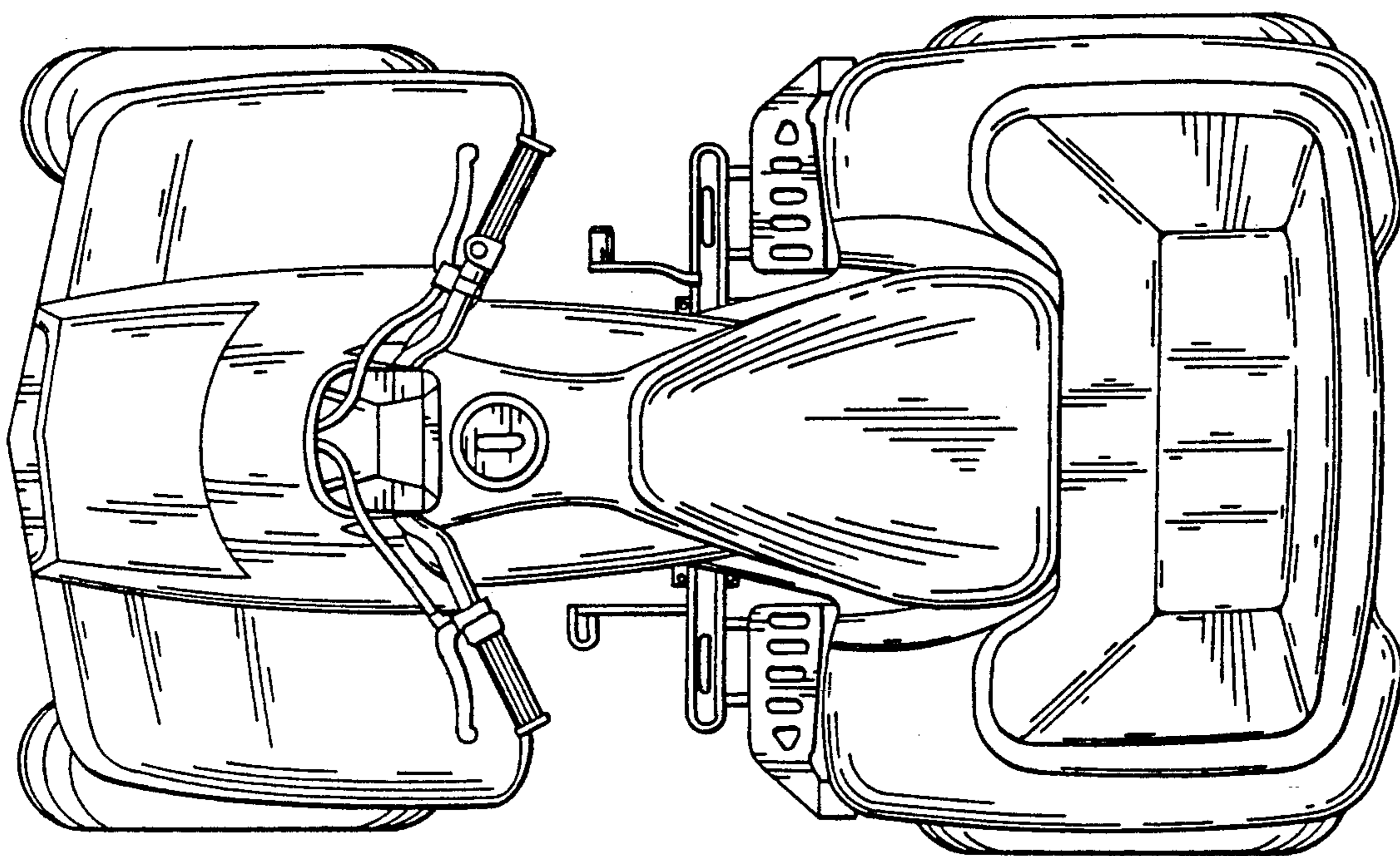

Fig. 6

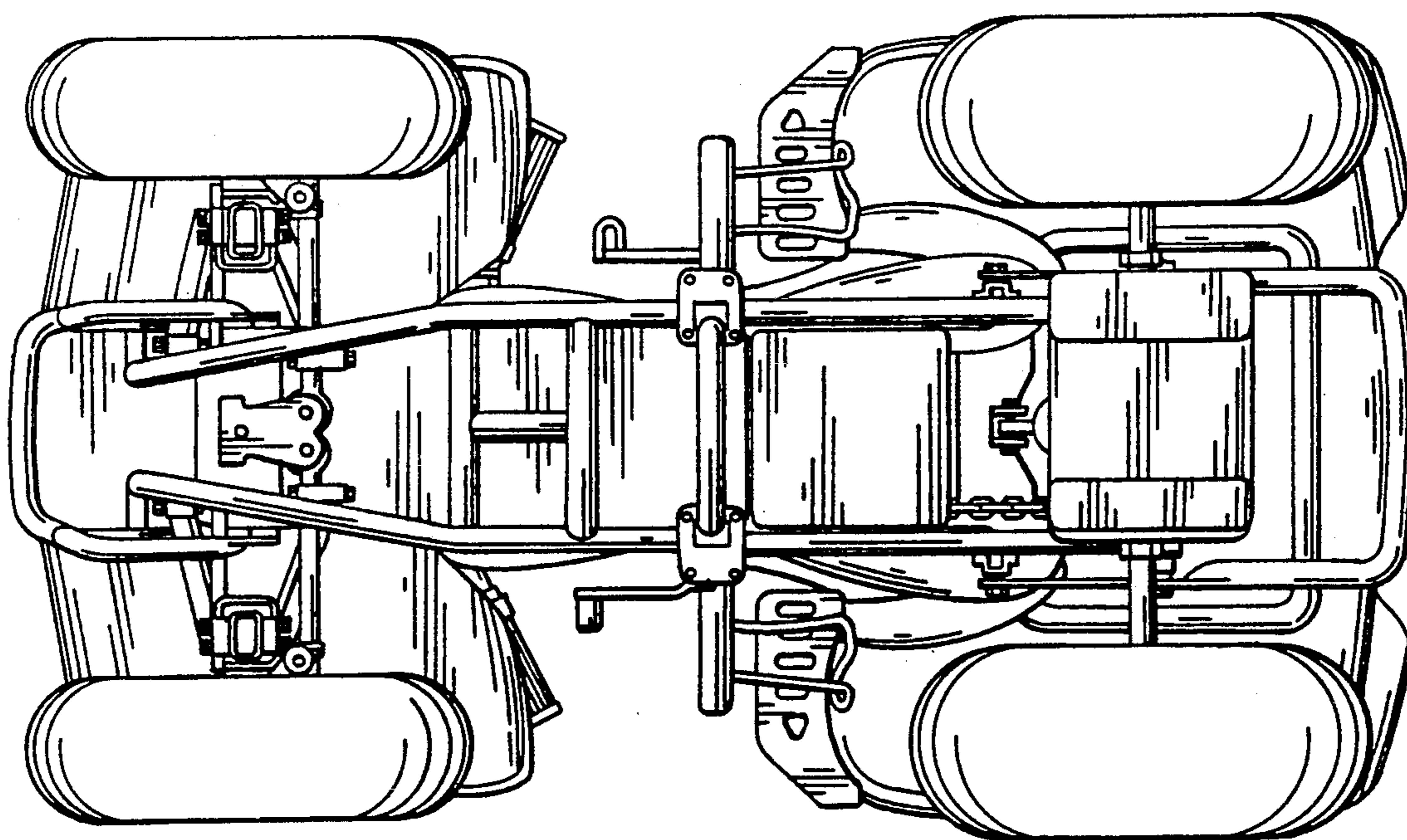

Fig. 7

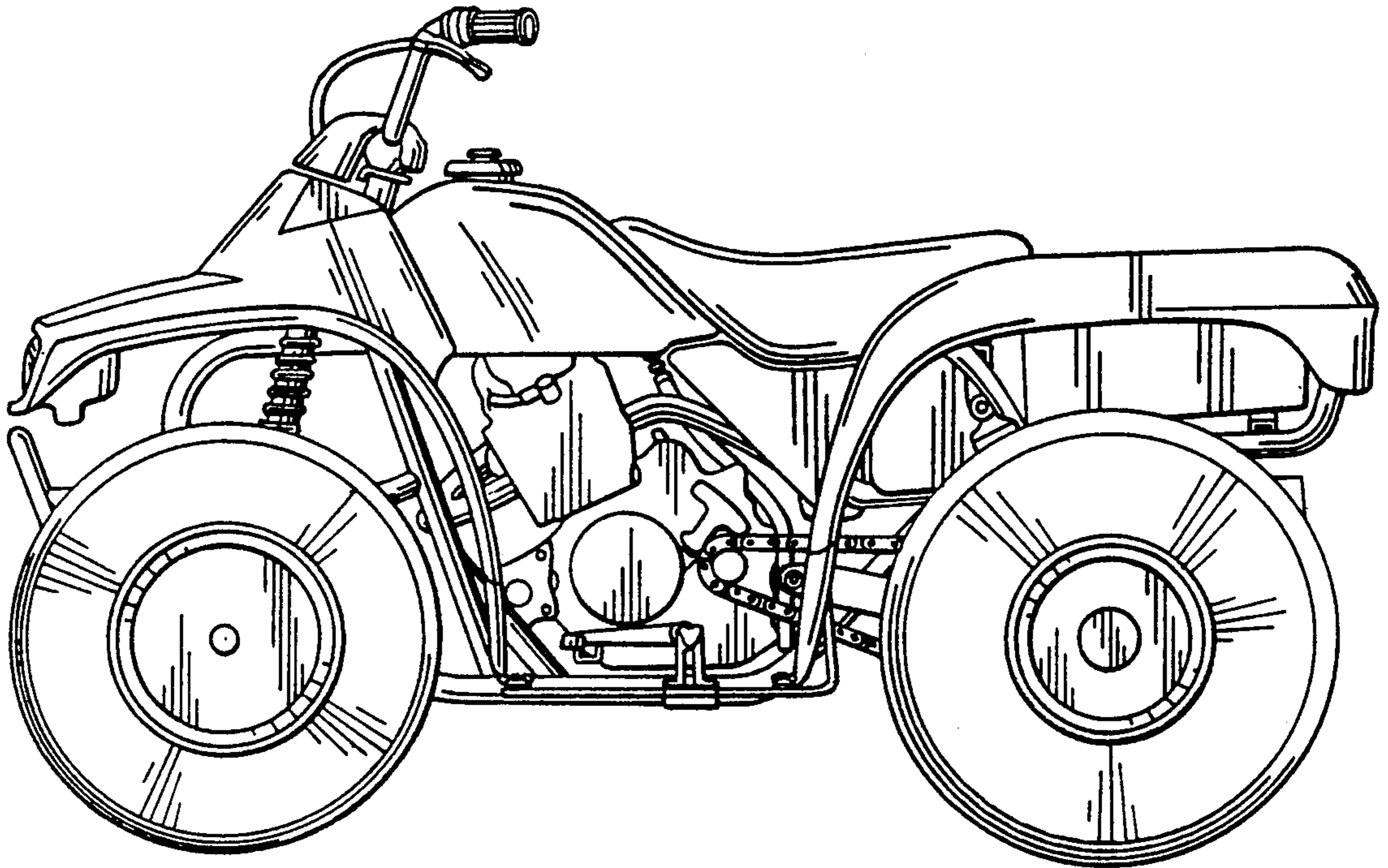

Fig. 8

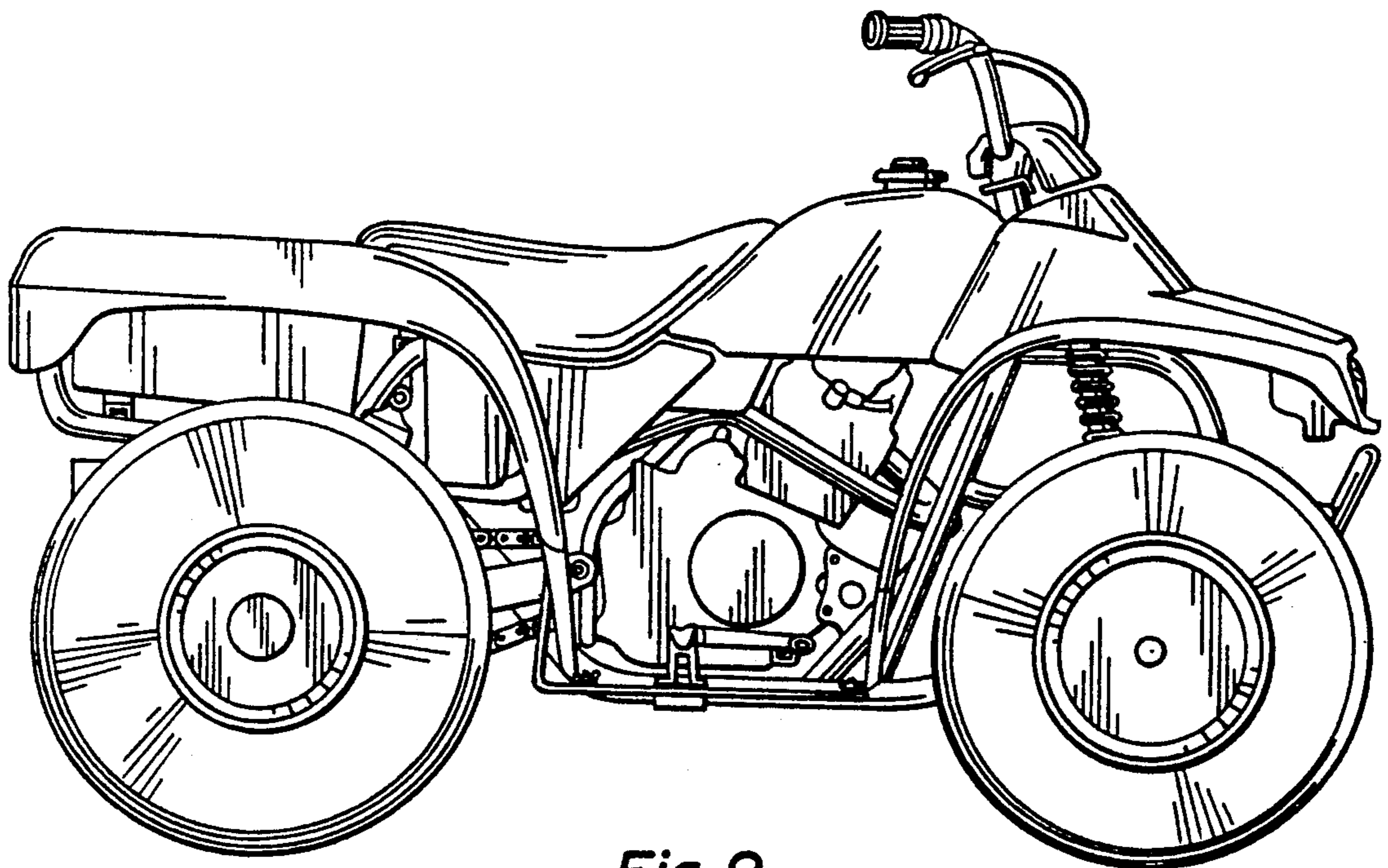

Fig. 9

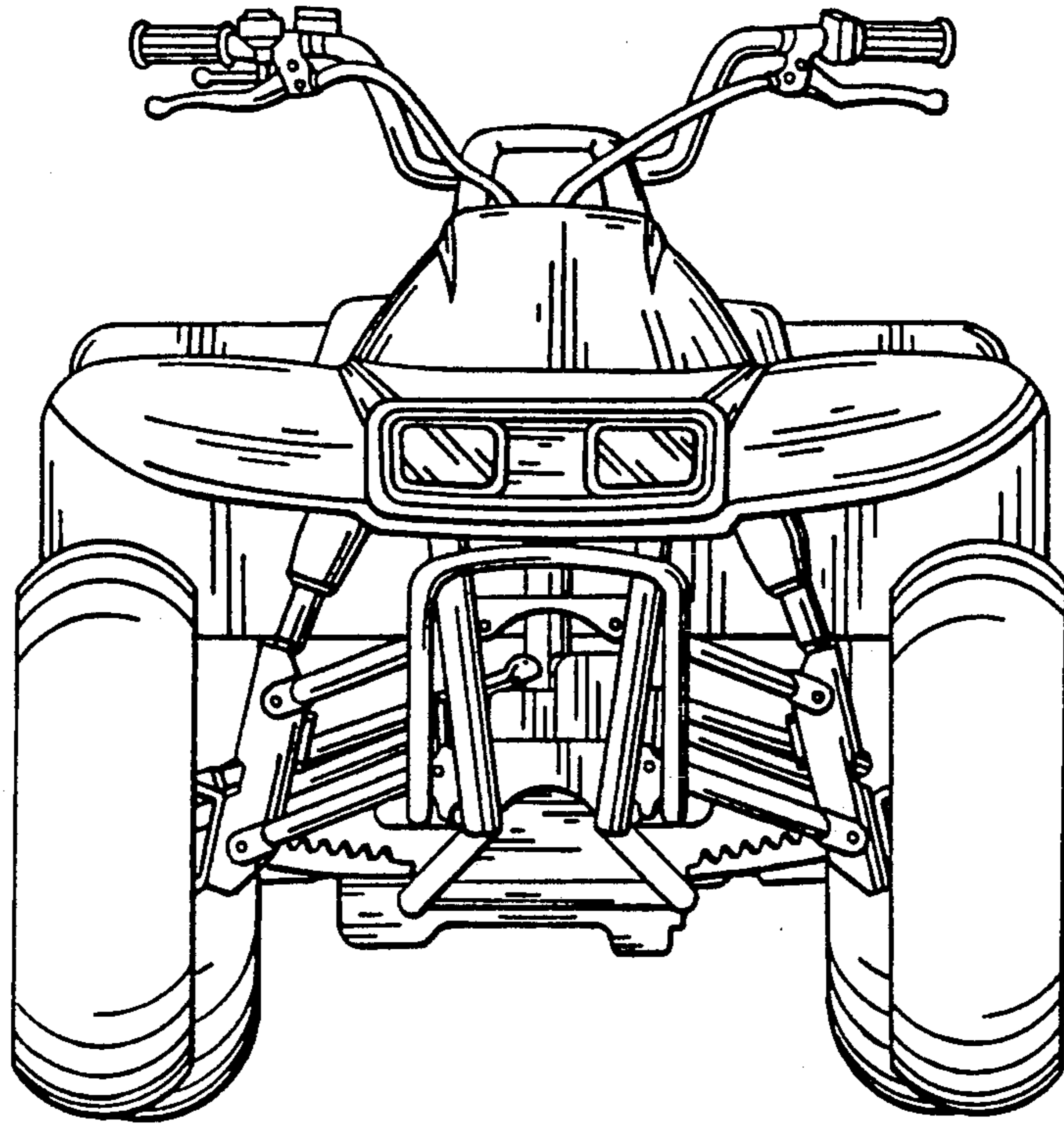

Fig. 10

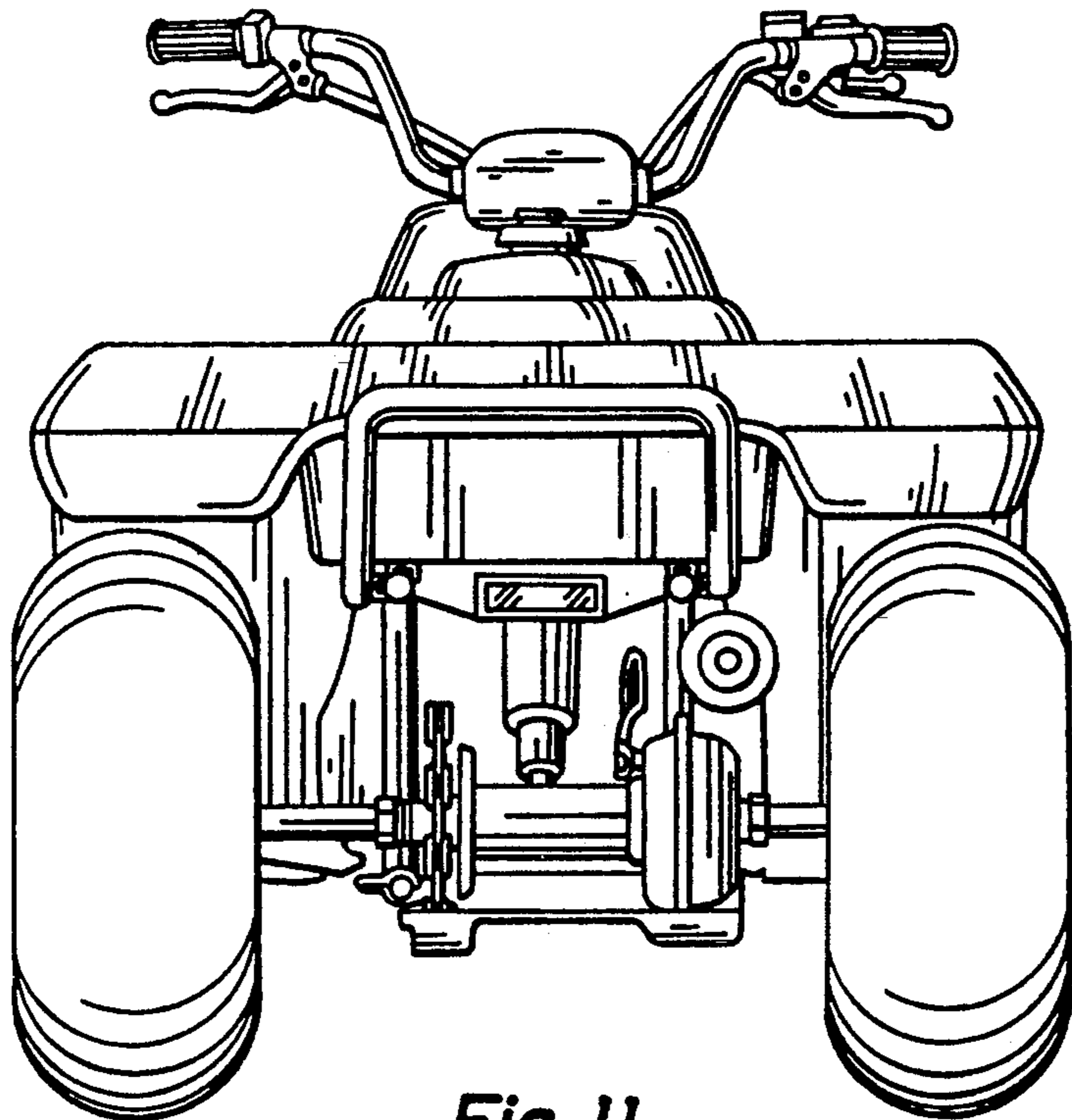

Fig. 11

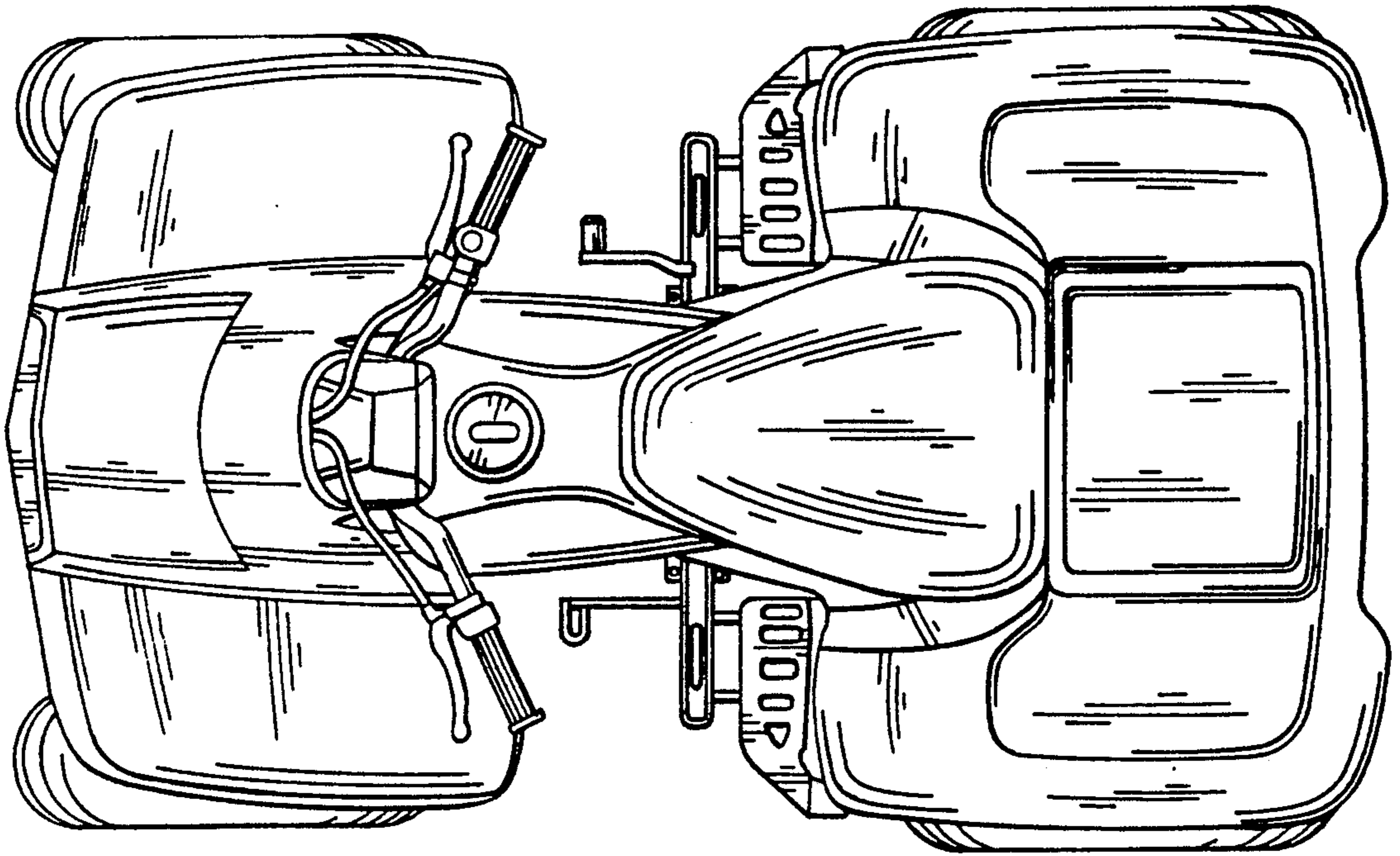

Fig. 12

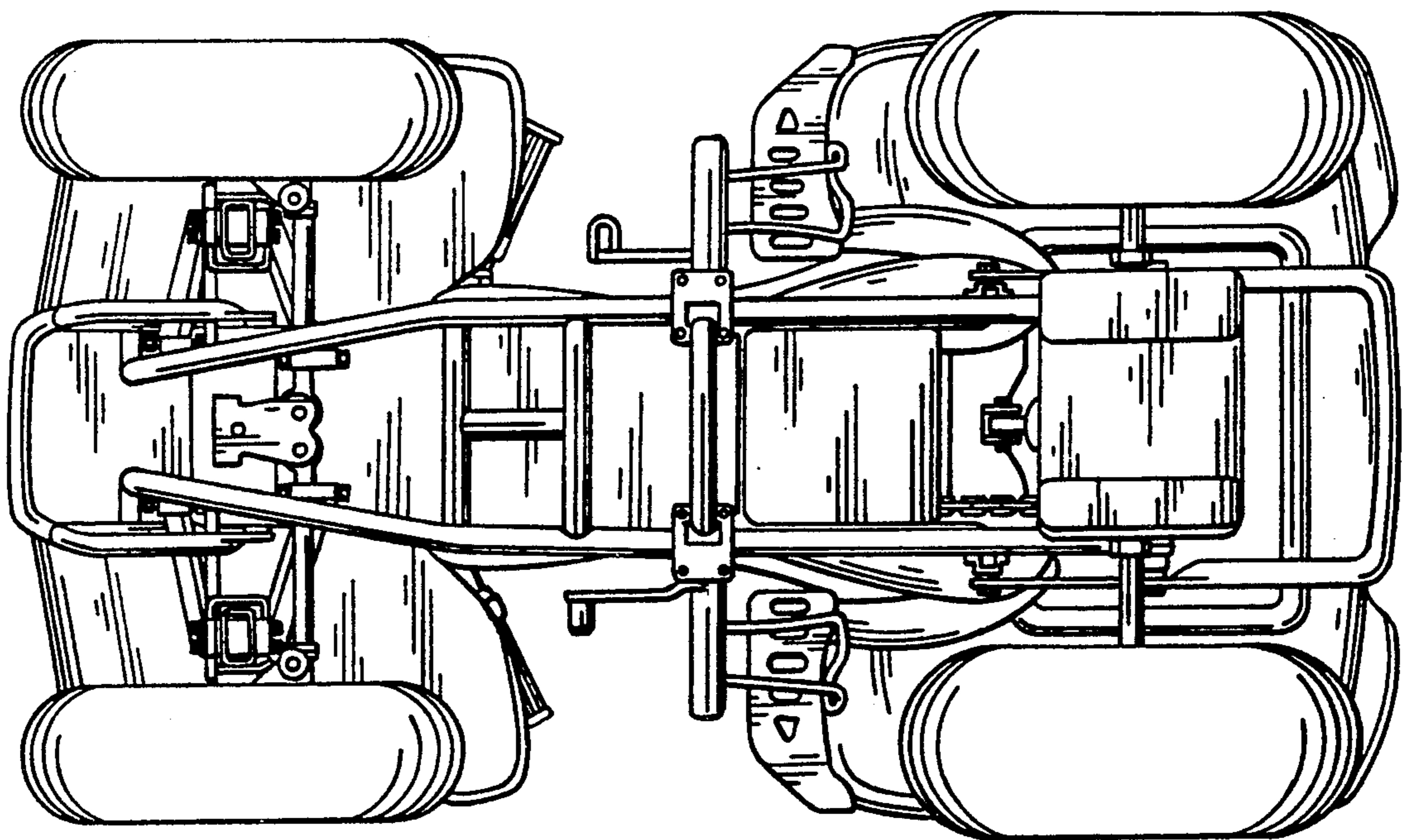

Fig. 13