



US00D325209S

# United States Patent [19]

Rollinson

[11] Patent Number: **Des. 325,209**

[45] Date of Patent: **\*\* Apr. 7, 1992**

[54] **TREAD ELEMENT FOR A WHEEL OR ENDLESS TRACK**

[76] Inventor: **Phillip J. Rollinson, 47 McCoy Street, Myaree, Australia**

[\*\*] Term: **14 Years**

[21] Appl. No.: **281,233**

[22] Filed: **Dec. 7, 1988**

[30] **Foreign Application Priority Data**

Sep. 14, 1988 [AU] Australia ..... 3108/88

[52] U.S. Cl. .... **D15/28; D12/153**

[58] Field of Search ..... D12/135, 149, 151, 153, D12/154; 152/209 A, 209 WT, 523; 305/35 R, 35 EB, 39, 53, 56; 180/9.1; D15/28

[56] **References Cited**

**U.S. PATENT DOCUMENTS**

D. 241,734 10/1976 Pfoertner ..... D12/154

D. 285,672 9/1985 Igarashi et al. .... D12/151  
D. 303,779 10/1989 Bonko ..... D12/151  
3,895,845 7/1975 Hale ..... 305/35 EB  
3,950,038 4/1976 Wood ..... 180/9.1  
4,469,379 9/1984 Kotyok, Jr. .... 305/35 EB

*Primary Examiner*—Bernard Ansher  
*Assistant Examiner*—Sandra Morris  
*Attorney, Agent, or Firm*—Handal & Morofsky

[57] **CLAIM**

The ornamental design for a ground engaging tread element for a wheel or endless track, as shown and described.

**DESCRIPTION**

FIG. 1 is a top, rear perspective view of a ground engaging tread element for a wheel or endless track, showing my new design;

FIG. 2 is a top, front perspective view thereof;

FIG. 3 is a bottom, rear perspective view thereof; and,

FIG. 4 is a bottom, front perspective view thereof.

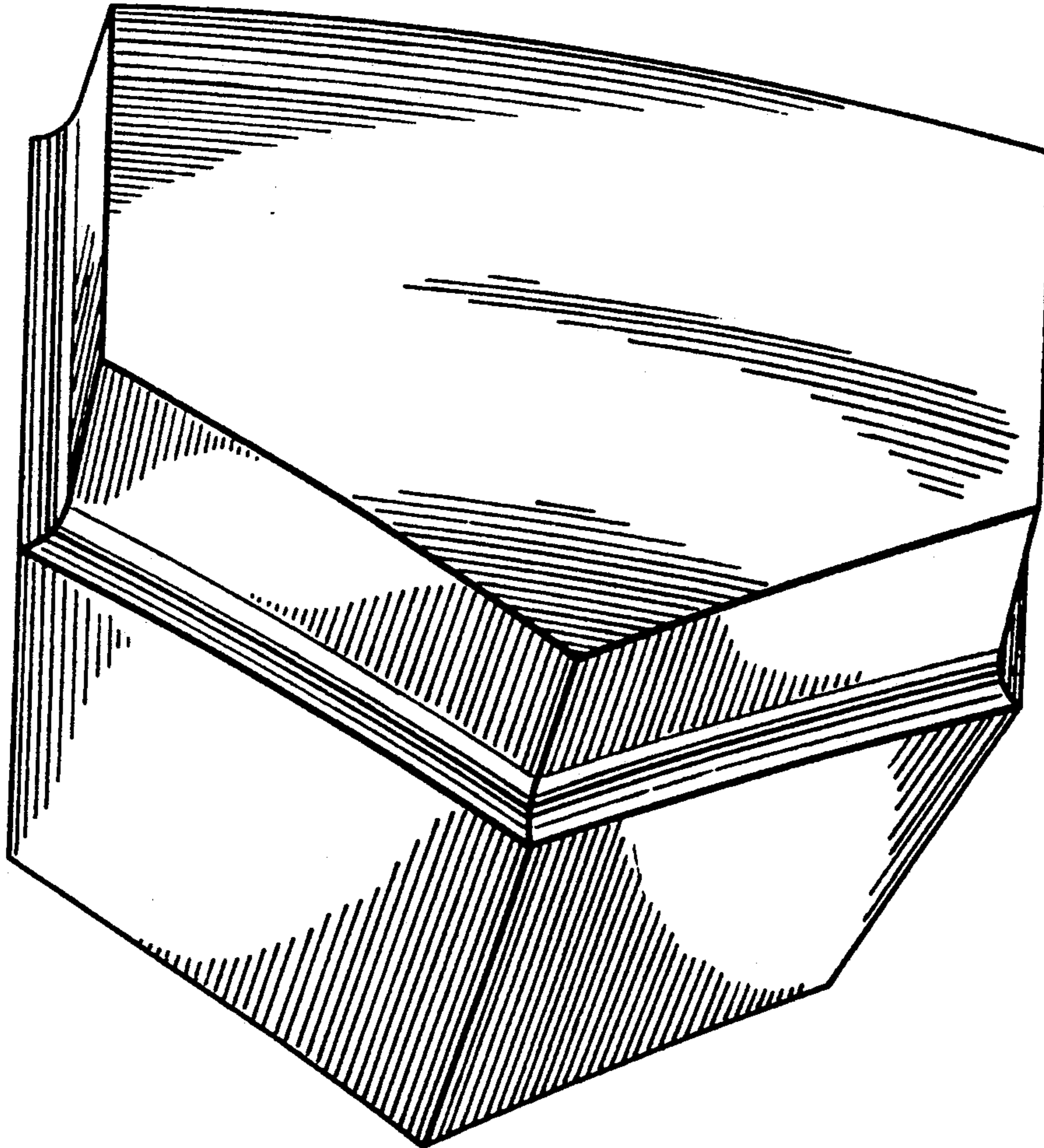

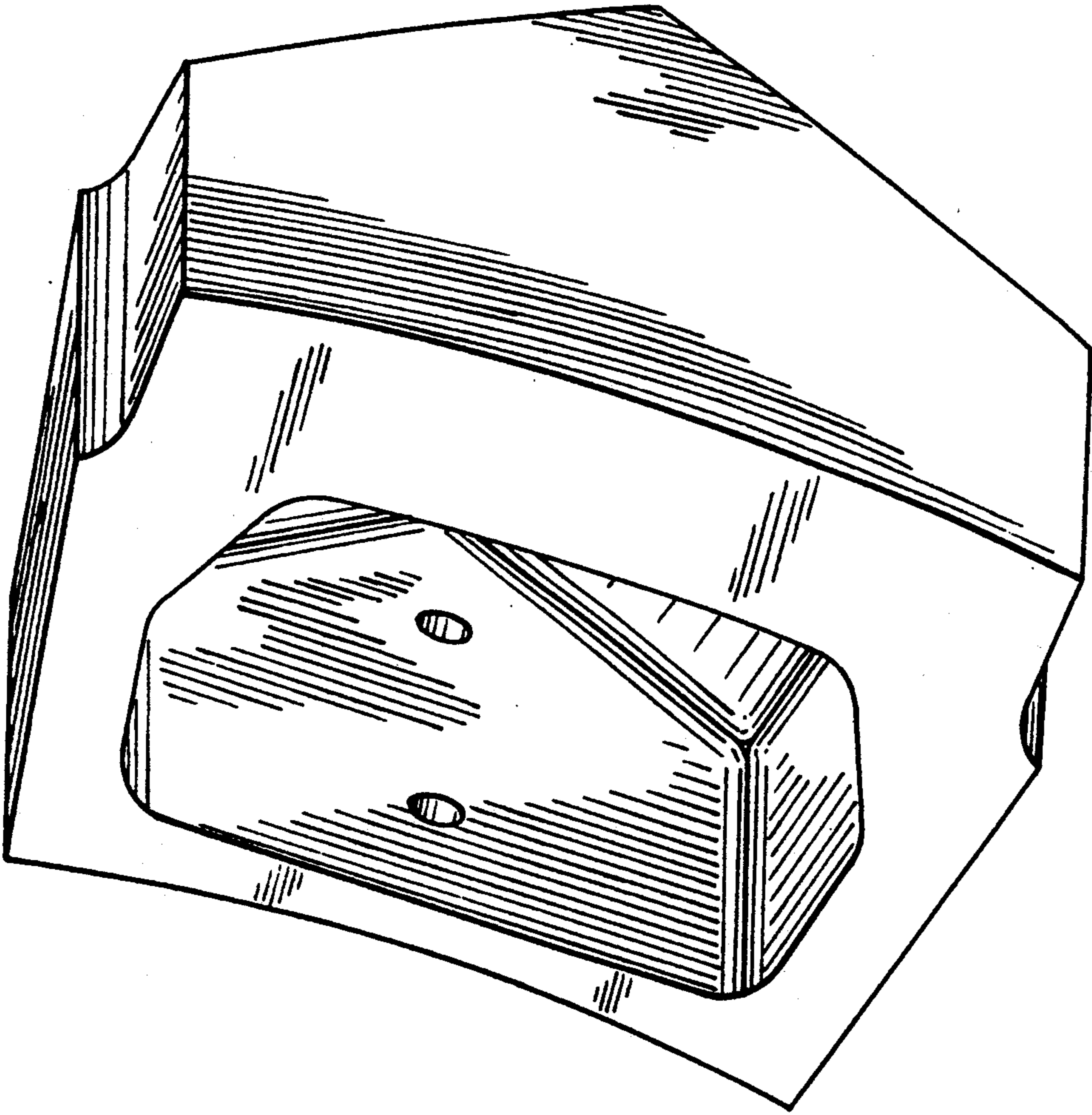

FIG. 1

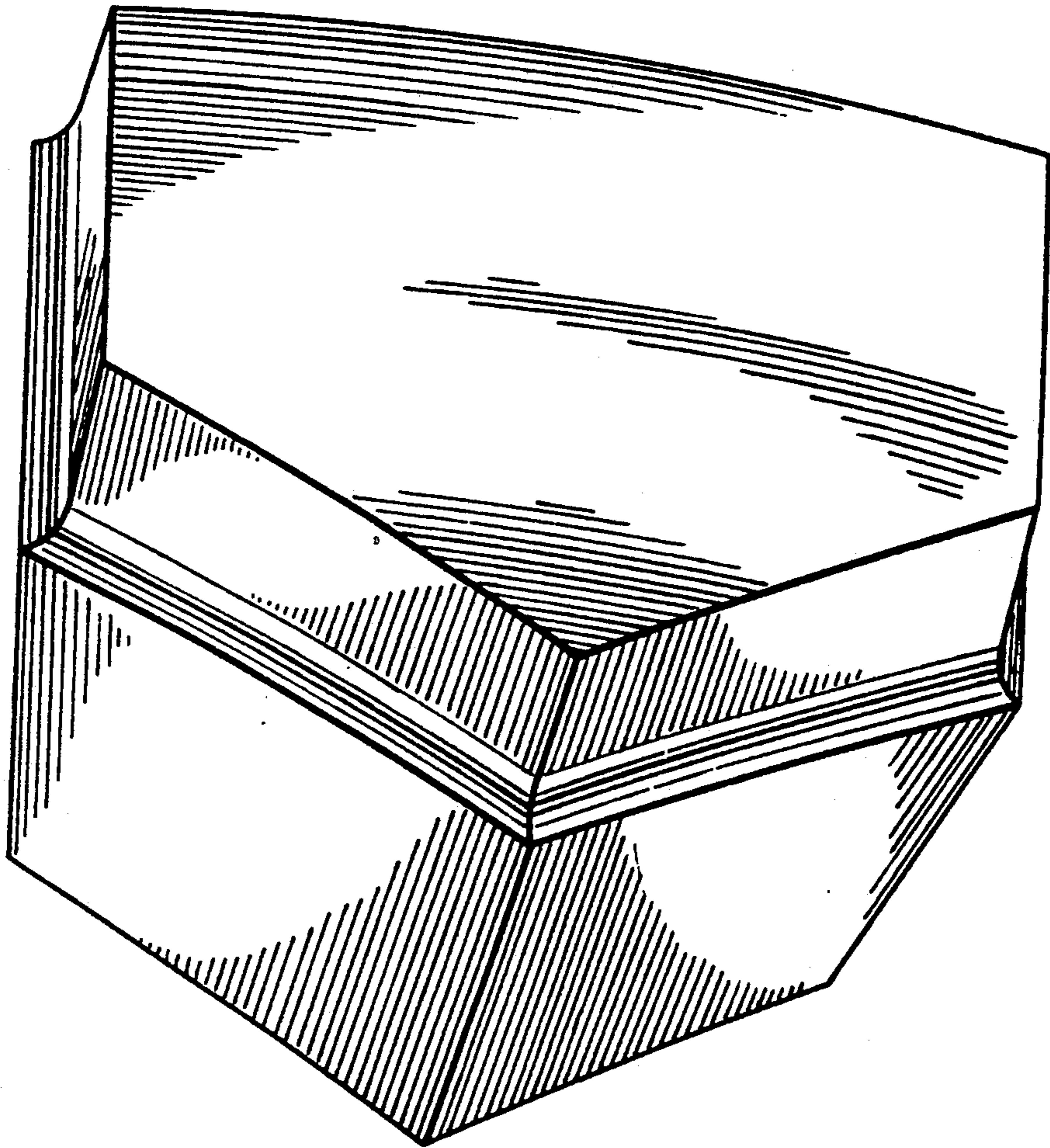

FIG. 2

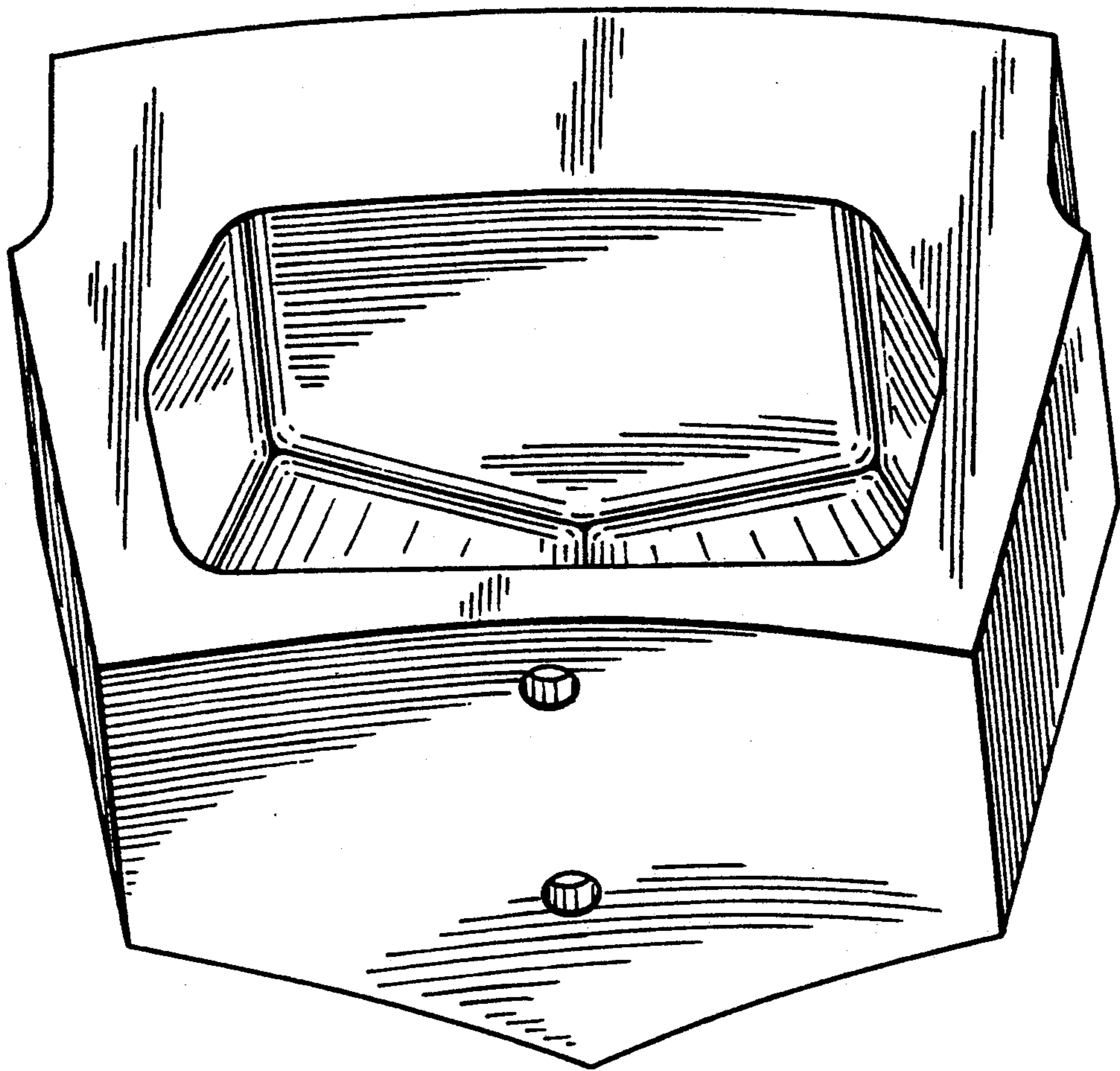

FIG. 3

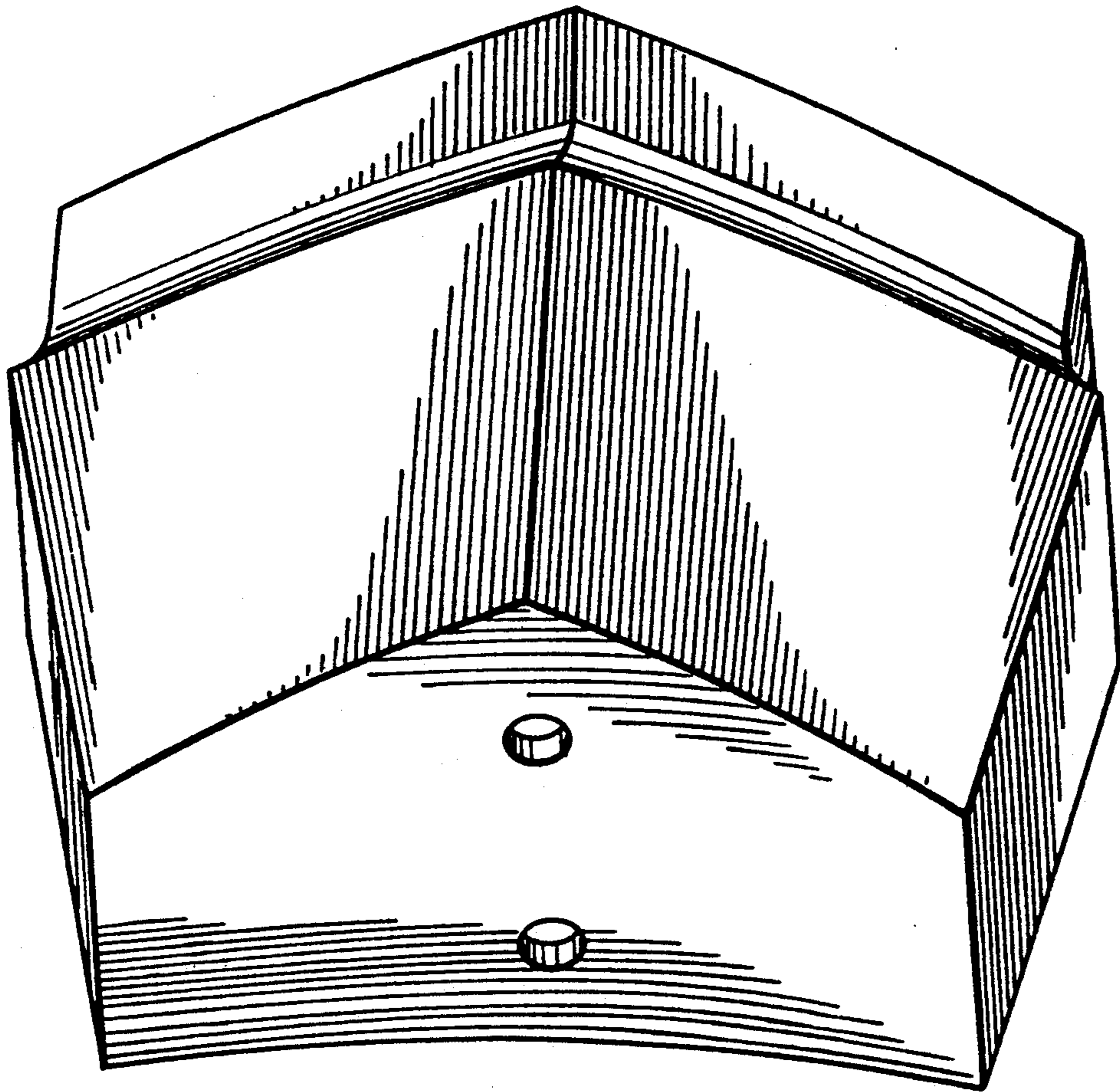

FIG. 4