



US00D325184S

United States Patent [19]

[11] Patent Number: **Des. 325,184**

Piller et al.

[45] Date of Patent: **** Apr. 7, 1992**

[54] **SPROCKET COVER FRONT FACE FOR MOUNTING ON THE DRIVE SPROCKET OF A BICYCLE**

[75] Inventors: **Barbara A. Piller, Miamisburg; Robert A. Hinschlager, Mendon, both of Ohio**

[73] Assignee: **Huffy Corporation, Miamisburg, Ohio**

[**] Term: **14 Years**

[21] Appl. No.: **432,277**

[22] Filed: **Nov. 6, 1989**

[52] U.S. Cl. **D12/127**

[58] Field of Search **D12/127; 474/144, 160, 474/140; 280/152.1, 160.1; 74/594.2, 609; 301/37 R, 37 SS, 37 P**

[56] **References Cited**

U.S. PATENT DOCUMENTS

D. 121,717	7/1940	Herold	D12/127
D. 298,613	11/1988	McMurtrey	D12/127
4,487,424	12/1984	Ellis	280/304.3

OTHER PUBLICATIONS

American Bicyclist & Motorcyclist, Jun. 1989, p. 47, Nan Wei Chain Guard, SPR-5007.

American Bicyclist & Motorcyclist, Dec. 1986, p. 97, Sate-Lite Wheel Cover.

Express LE Man's Bike—published 1986.

Techtra Lady's Bike—published 1986.

Model No. 36688 Man's Bike—published 1987.

Primary Examiner—James M. Gandy

Assistant Examiner—Melody N. Brown

Attorney, Agent, or Firm—Biebel & French

[57] **CLAIM**

The ornamental design for a sprocket cover front face for mounting on the drive sprocket of a bicycle, as shown and described.

DESCRIPTION

FIG. 1 is a front elevational view of a sprocket cover front face for mounting on the drive sprocket of a bicycle showing my new design, wherein the stipple shading shown in the lower sector shaped areas represents contrast in color and/or surface texture; and, FIG. 2 is a perspective view thereof, it being understood that the broken lines are for illustrative purposes only and form no part of the claimed design.

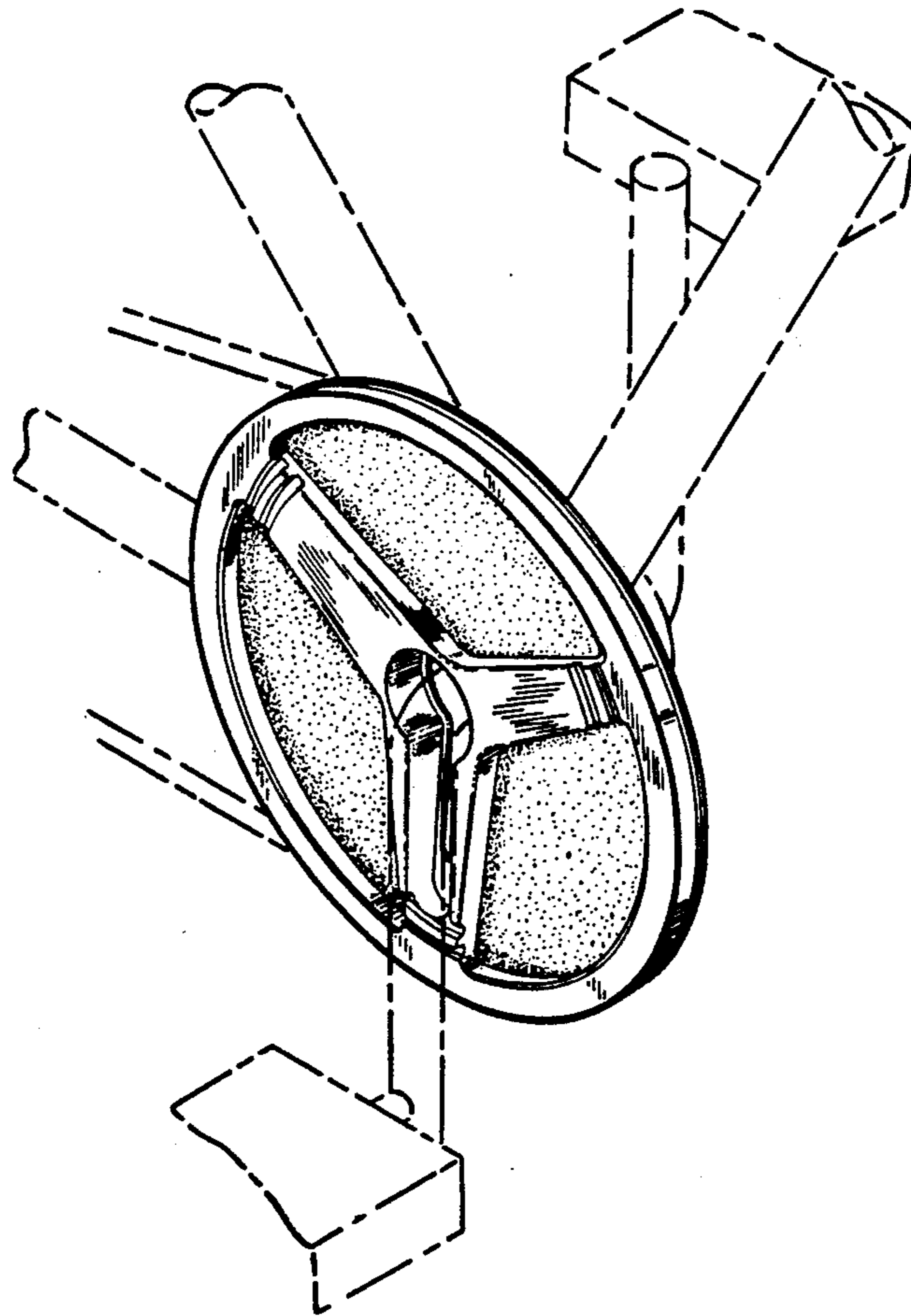

FIG - 1

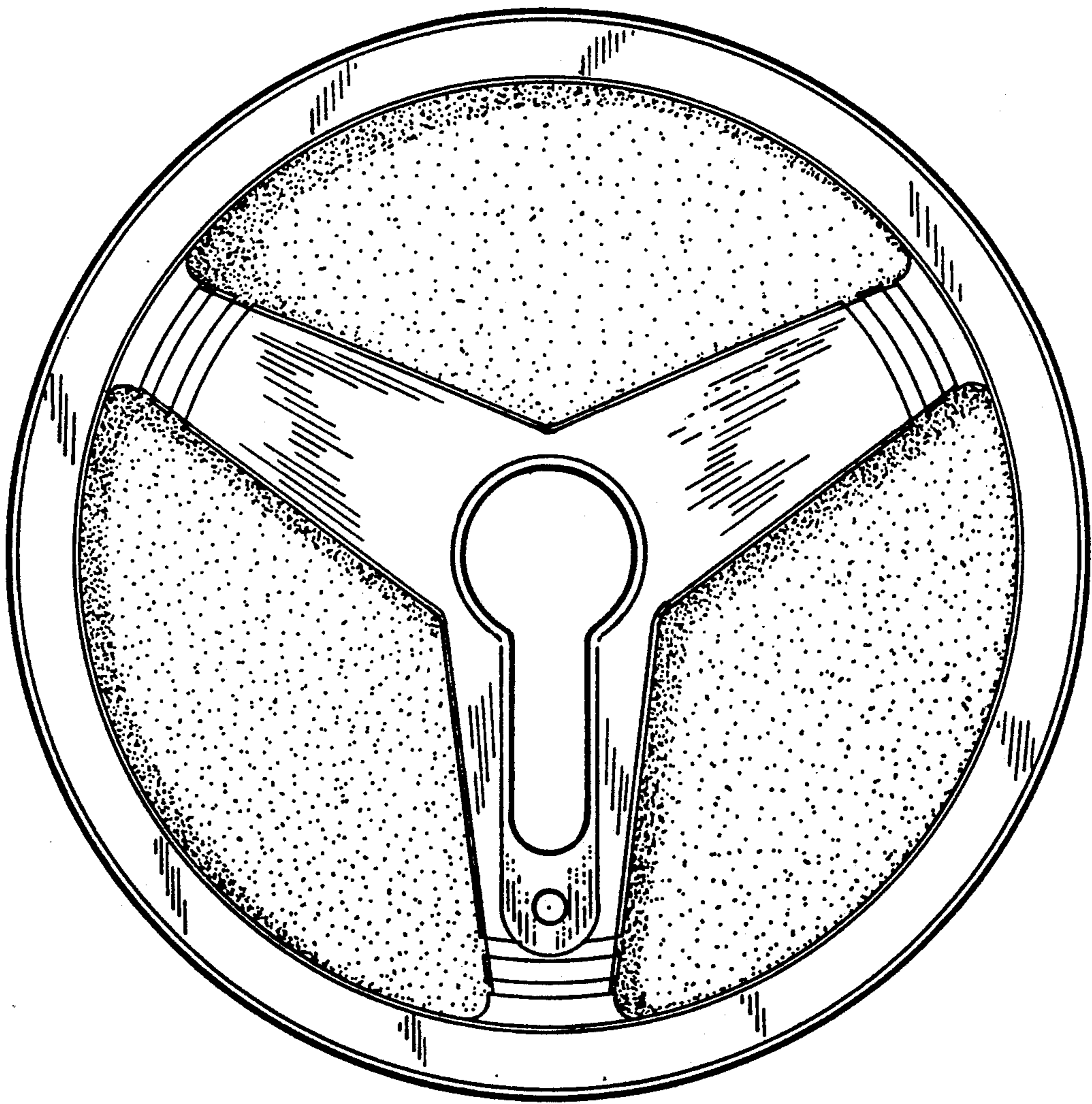

FIG-2

