



US00D325019S

United States Patent [19]
Boyer

[11] **Patent Number: Des. 325,019**
[45] **Date of Patent: ** Mar. 31, 1992**

[54] **AUTOMOBILE WHEEL COVER**

[56] **References Cited**

[75] **Inventor: Boyke Boyer, Seefeld, Fed. Rep. of Germany**

[73] **Assignee: Bayerische Motoren Werke AG, Fed. Rep. of Germany**

[**] **Term: 14 Years**

[21] **Appl. No.: 481,396**

[22] **Filed: Feb. 20, 1990**

[30] **Foreign Application Priority Data**

Aug. 18, 1989 [DE] Fed. Rep. of Germany M8905980.8

[52] **U.S. Cl. D12/211**

[58] **Field of Search D12/209, 211; 301/64 R, 301/65 SD, 65, 37 R**

U.S. PATENT DOCUMENTS

D. 92,600	6/1934	Hunt	D12/211
D. 225,842	1/1973	Clement	D12/209
D. 248,848	8/1978	Taitani et al.	D12/209
D. 285,676	9/1986	Clark	D12/209
D. 295,509	5/1988	Boyer	D12/211

Primary Examiner—James M. Gandy
Attorney, Agent, or Firm—Evenson, Wands, Edwards, Lenahan & McKeown

[57] **CLAIM**

The ornamental design for an automobile wheel cover, as shown and described.

DESCRIPTION

FIG. 1 is a front elevation view of an automobile wheel cover showing my new design;
FIG. 2 is a side elevation view thereof;
FIG. 3 is a left, front perspective view thereof;
FIG. 4 is an enlarged fragmentary cross sectional view thereof taken along line IV—IV of FIG. 1; and,
FIG. 5 is an enlarged fragmentary cross sectional view thereof taken along line V—V of FIG. 1.

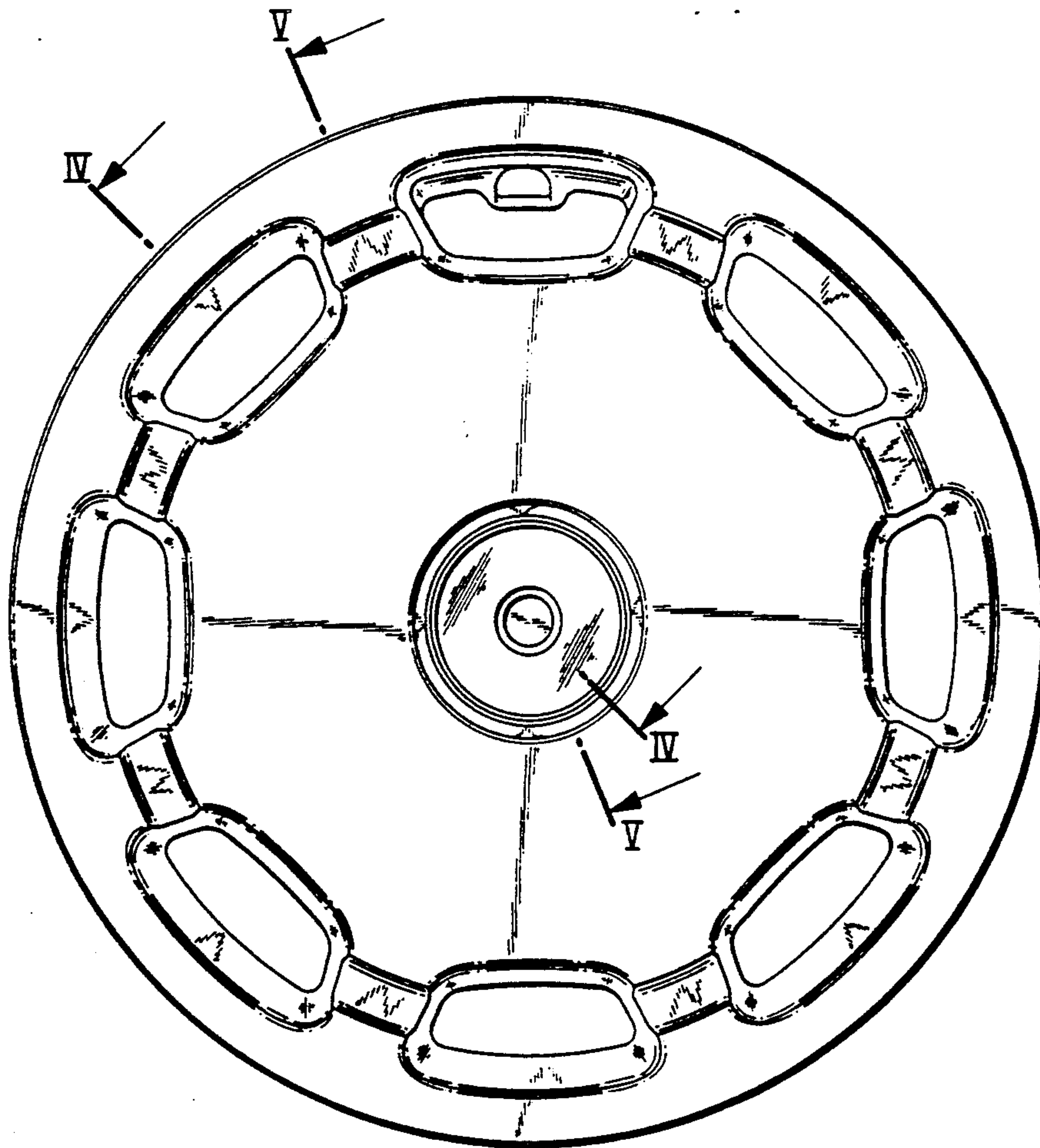

Fig. 1

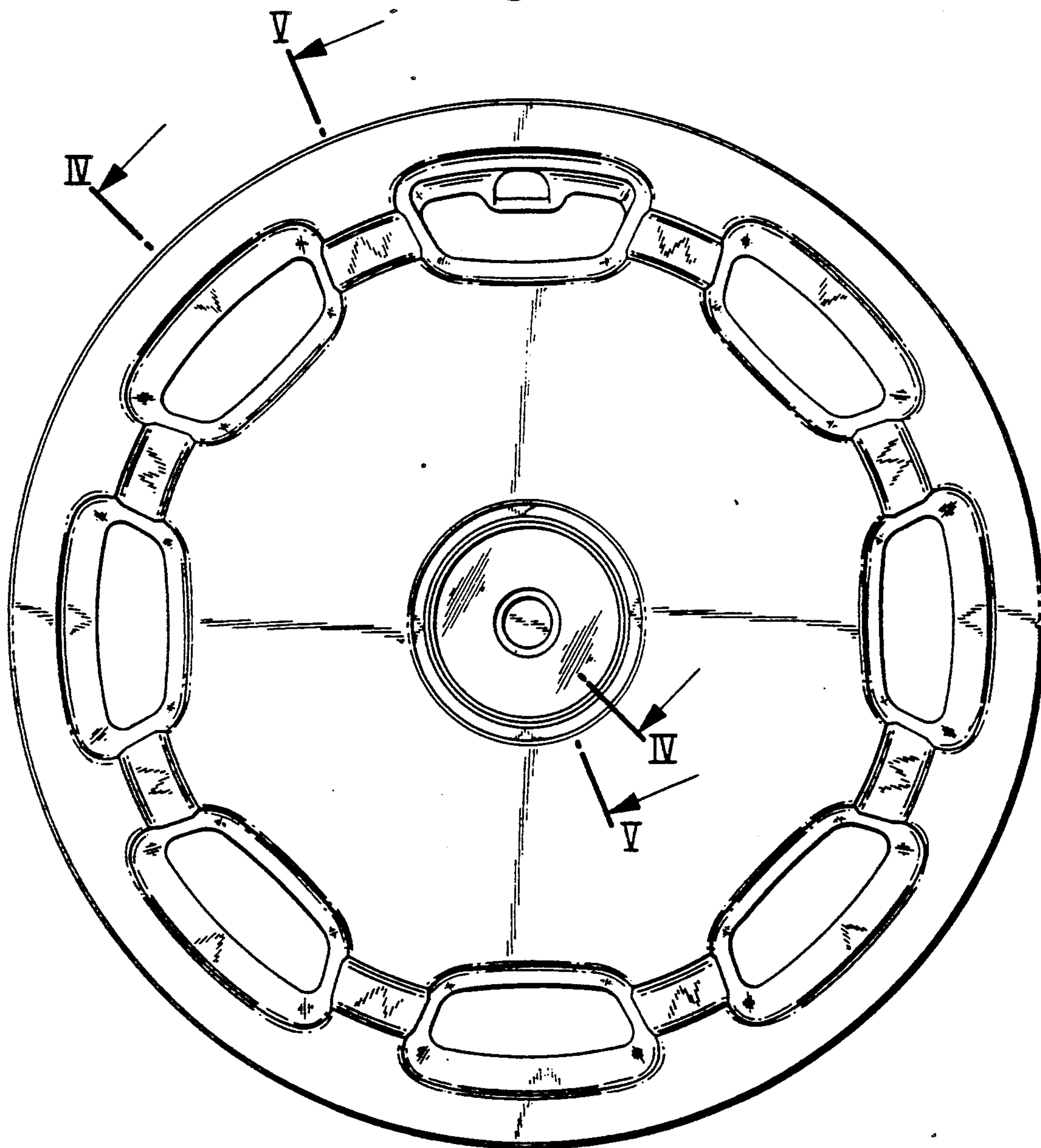

Fig. 2



Fig. 3

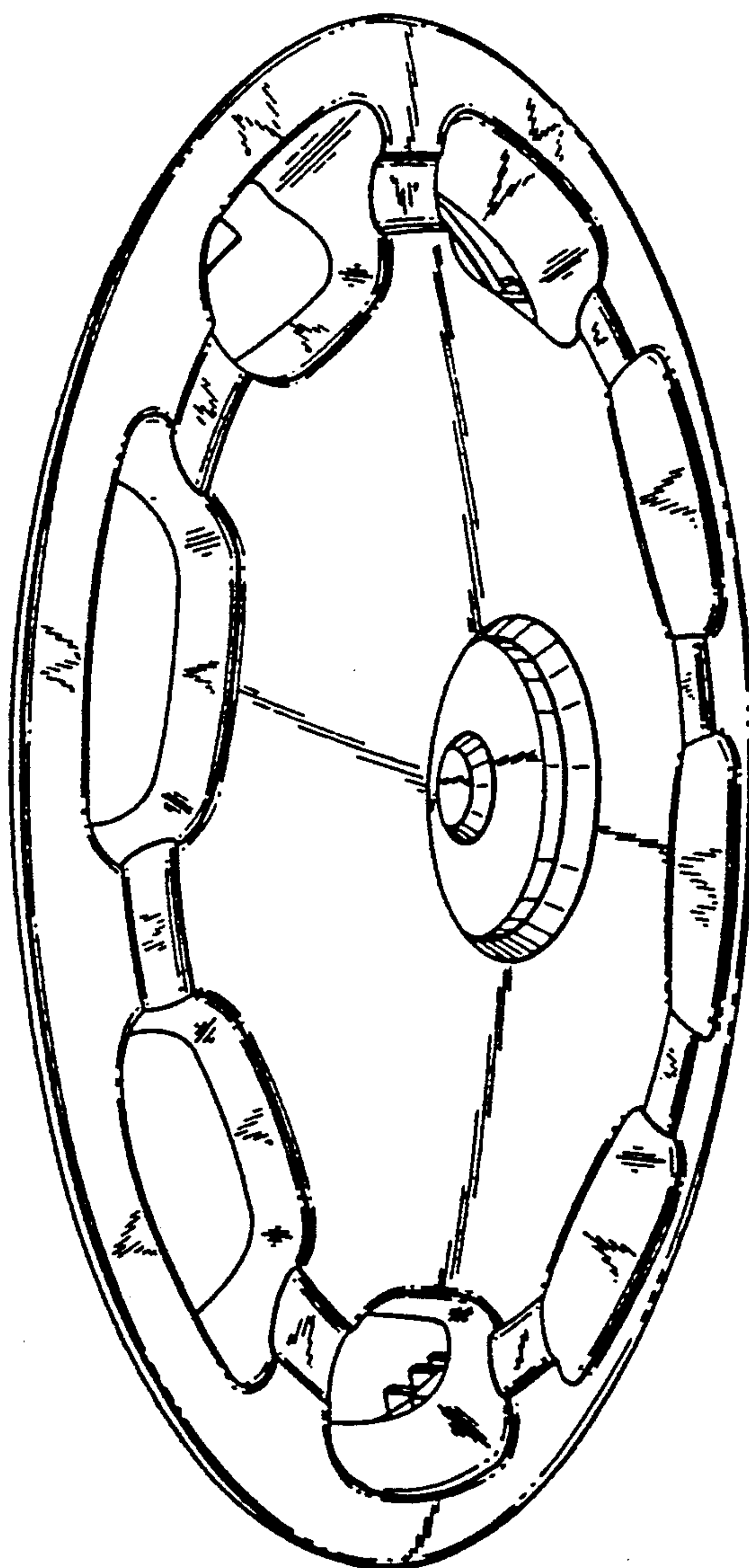

Fig. 4

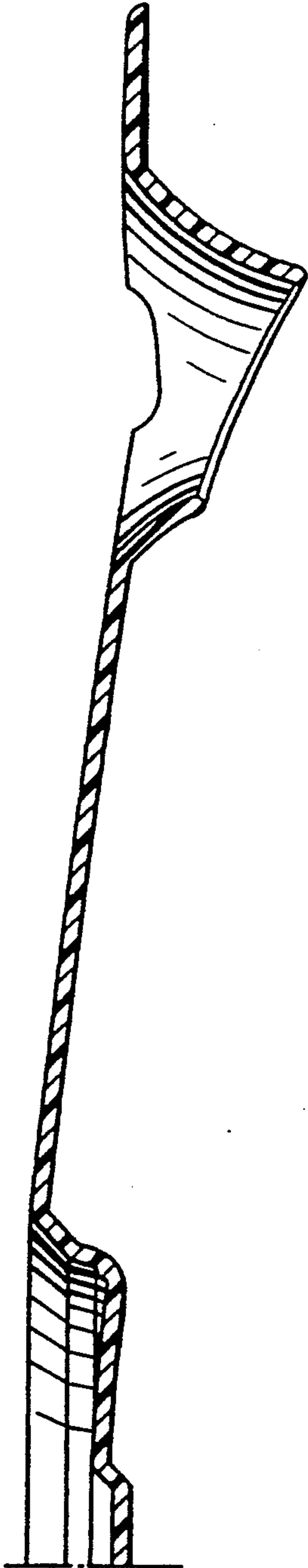

Fig. 5

