



US00D324867S

United States Patent [19]

[11] Patent Number: **Des. 324,867**

Lyndhurst et al.

[45] Date of Patent: **** Mar. 24, 1992**

[54] VALVE COVER FOR AN ENGINE

4,538,560 9/1985 Alden 123/90.38
4,788,950 12/1988 Finley 123/198 E

[75] Inventors: **Francis R. Lyndhurst**, Costa Mesa;
Philip T. Lieb, Manhattan Beach,
both of Calif.

Primary Examiner—A. Hugo Word
Assistant Examiner—R. Seifert
Attorney, Agent, or Firm—William W. Haefliger

[73] Assignee: **Thunder Power, Inc.**, Redondo
Beach, Calif.

[57] **CLAIM**

[**] Term: **14 Years**

The ornamental design for a valve cover for an engine,
as shown and described.

[21] Appl. No.: **446,488**

DESCRIPTION

[22] Filed: **Dec. 5, 1989**

[52] U.S. Cl. **D15/5**; 123/90.38;
123/198 E

[58] Field of Search **D15/1, 3, 5**; 123/90.38,
123/195 C, 198 E, 196 R

FIG. 1 is a top plan view of a valve cover for an engine;
FIG. 2 is a front elevational view;
FIG. 3 is a bottom plan view;
FIG. 4 is a rear elevational view;
FIG. 5 is a sectional view taken along the lines 5—5 of
FIG. 1;
FIG. 6 is a left end elevational view; the opposite side
being a mirror image;
FIG. 7 is a sectional view taken along the lines 7—7 of
FIG. 1; and,
FIG. 8 is a sectional view taken along the lines 8—8 of
FIG. 1.

[56] **References Cited**

U.S. PATENT DOCUMENTS

- D. 252,878 9/1979 Bellino et al. D15/5
- D. 305,123 12/1989 Garrett et al. D15/5
- D. 305,767 1/1990 Tauschke D15/5

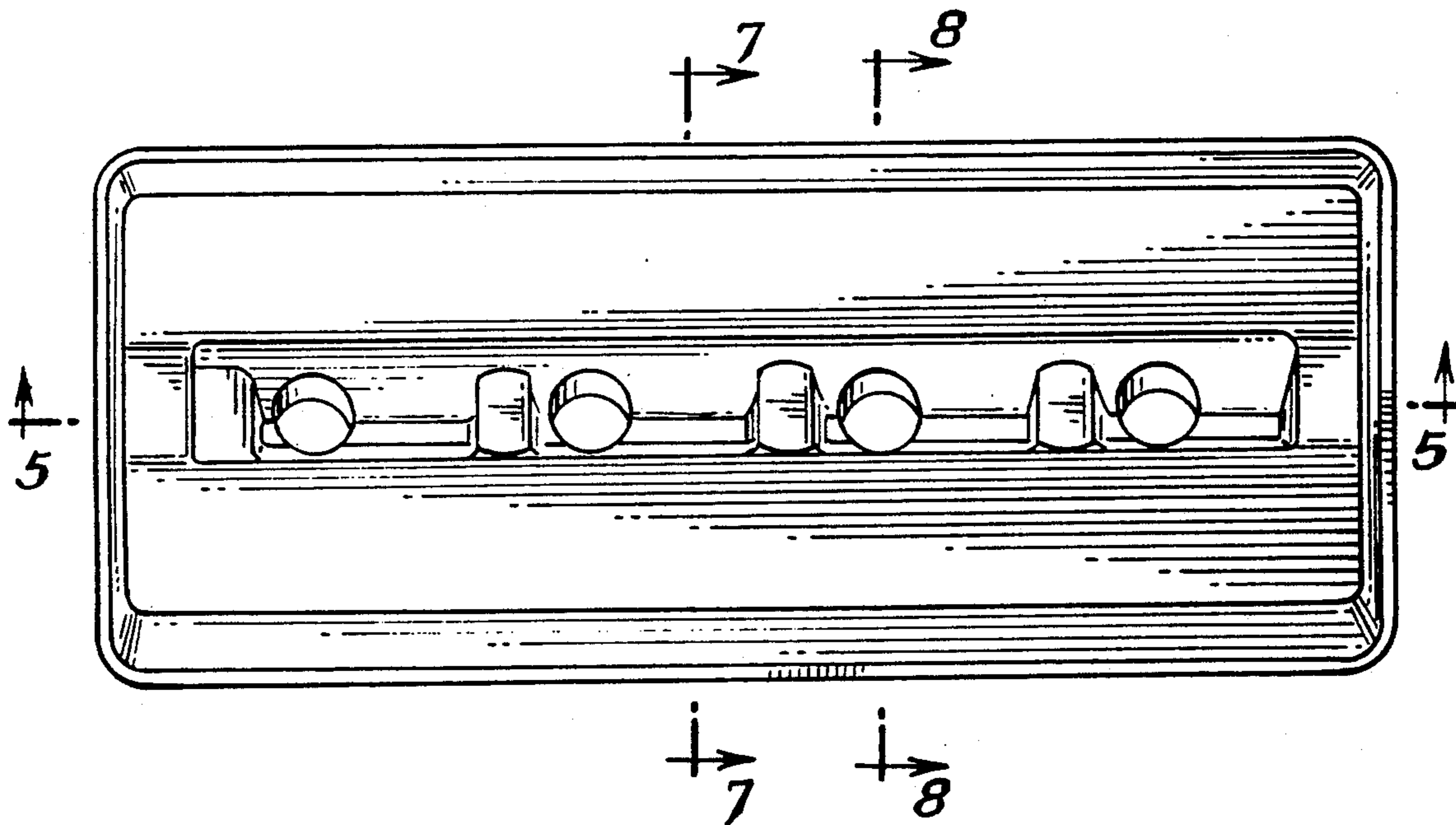

FIG. 1.

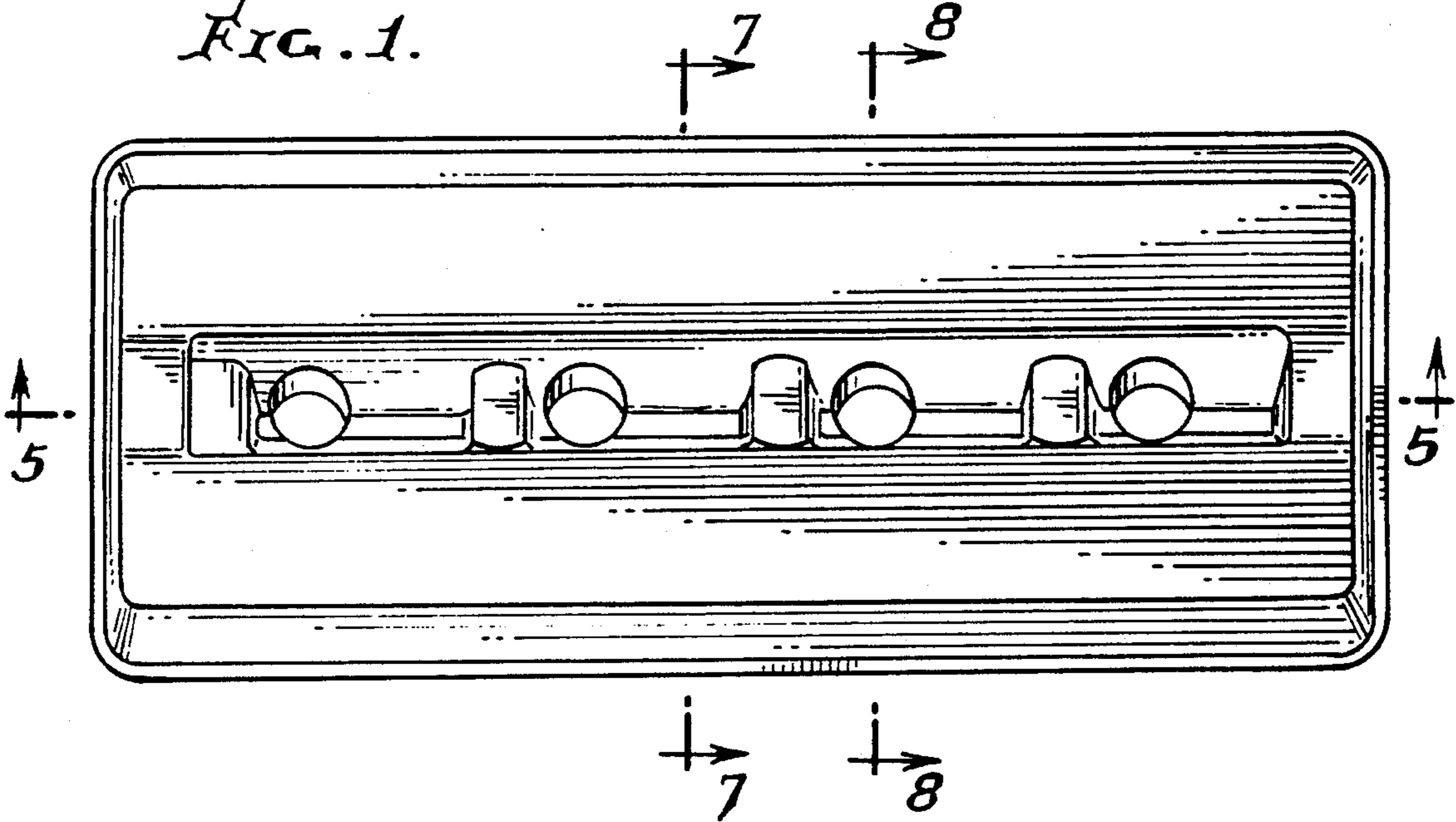

FIG. 2.

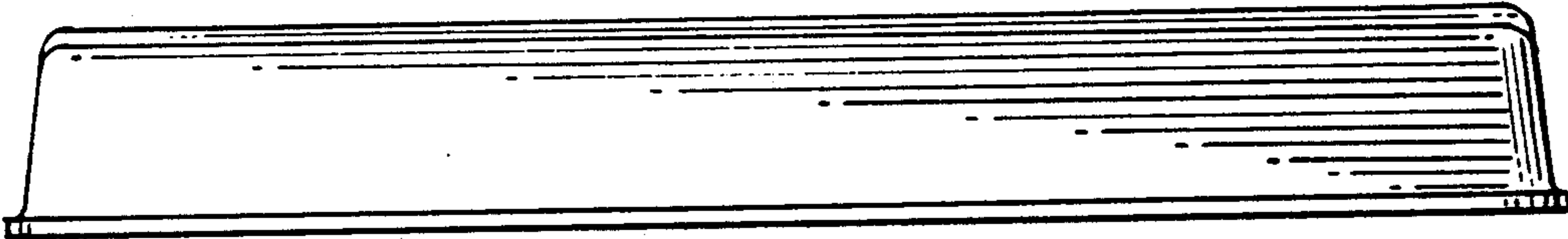

FIG. 3.

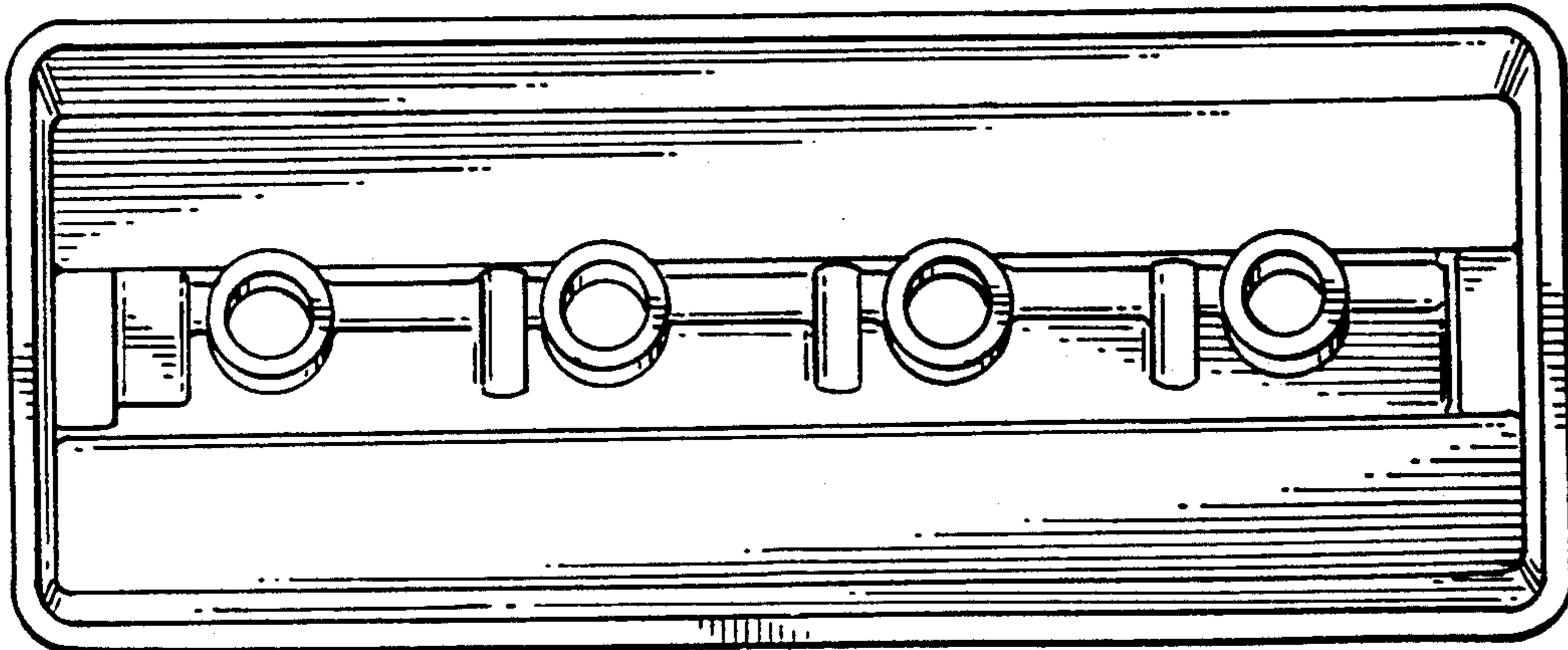

FIG. 4.

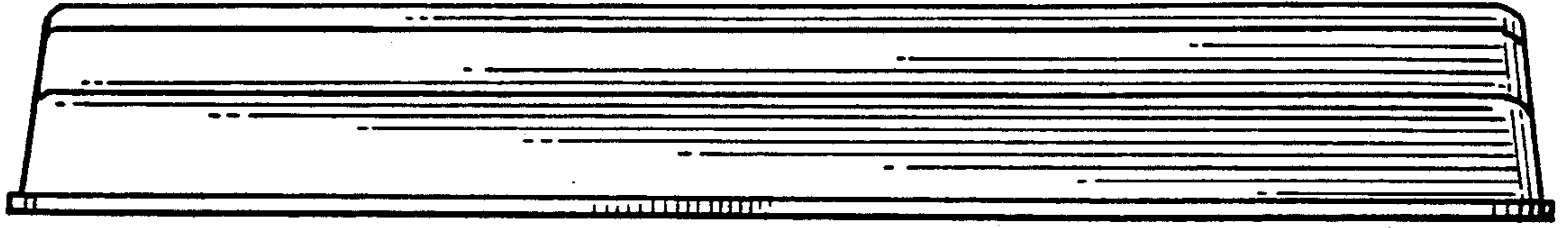

FIG. 5.

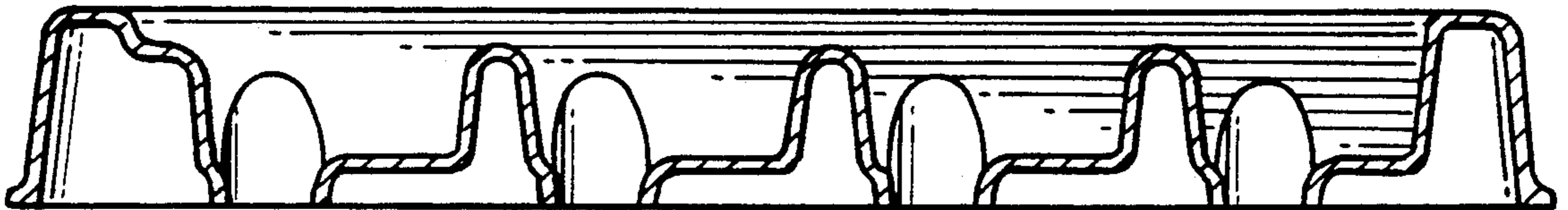

FIG. 6.

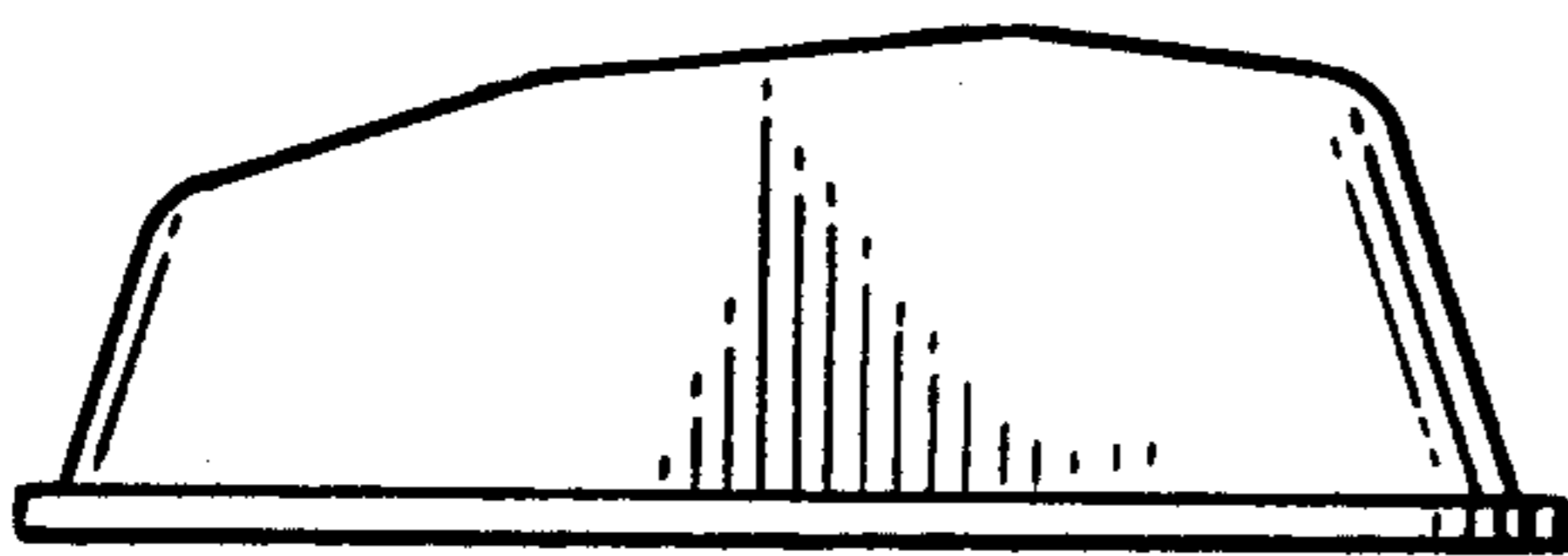

FIG. 7.

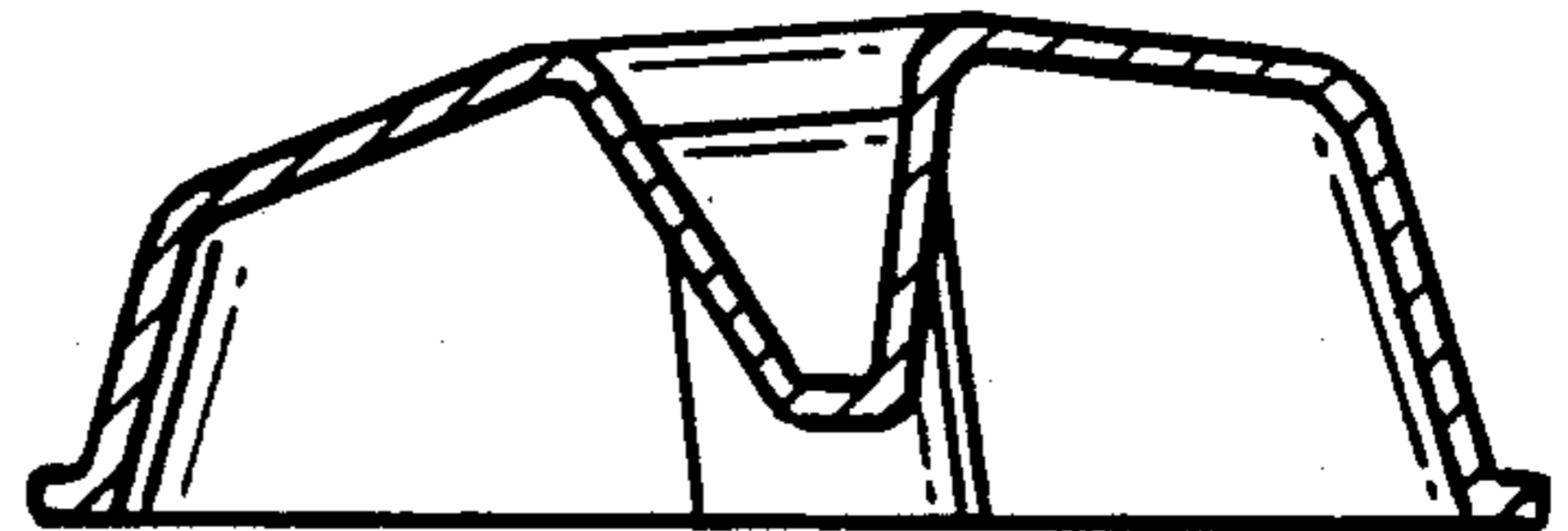

FIG. 8.

