



US00D324599S

United States Patent [19]

[11] Patent Number: Des. 324,599

Bailey

[45] Date of Patent: ** Mar. 10, 1992

[54] FOLDABLE MOTOR VEHICLE ENGINE STAND

4,705,264 11/1987 Hawkins et al. 269/17

[76] Inventor: Keith B. Bailey, 8224 Butternut Dr., Citrus Heights, Calif. 95621

Primary Examiner—James M. Gandy
Assistant Examiner—H. Bayham
Attorney, Agent, or Firm—Lothrop & West

[**] Term: 14 Years

[57] CLAIM

[21] Appl. No.: 487,073

The ornamental design for a foldable motor vehicle engine stand, as shown and described.

[22] Filed: Mar. 1, 1990

DESCRIPTION

[52] U.S. Cl. D34/31

[58] Field of Search D34/31, 33; 269/55, 269/296, 17, 59, 77; 248/647

FIG. 1 is a perspective view of a foldable motor vehicle engine stand, showing my new design; FIG. 2 is an elevational view of one side thereof, the opposite side being a mirror image of the figure shown; FIG. 3 is a front elevational view thereof; FIG. 4 is a rear elevational view thereof; FIG. 5 is a top plan view thereof; and, FIG. 6 is a bottom plan view thereof; and FIG. 7 is a top plan view thereof in folded position.

[56] References Cited

U.S. PATENT DOCUMENTS

2,997,292	8/1961	Lucker et al.	269/17
4,183,511	1/1980	Marek	269/17
4,533,127	8/1985	Hawkins	269/17

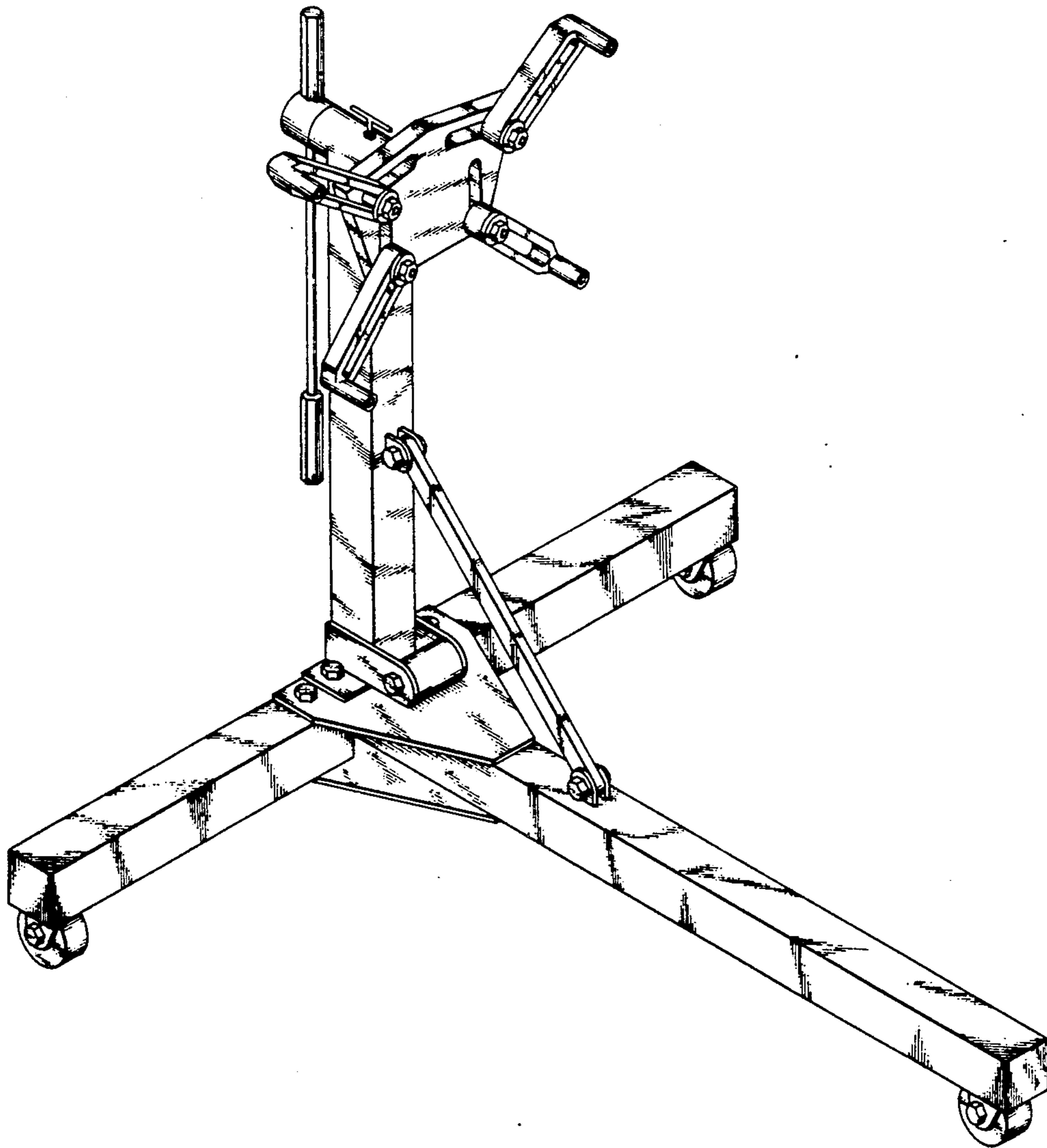

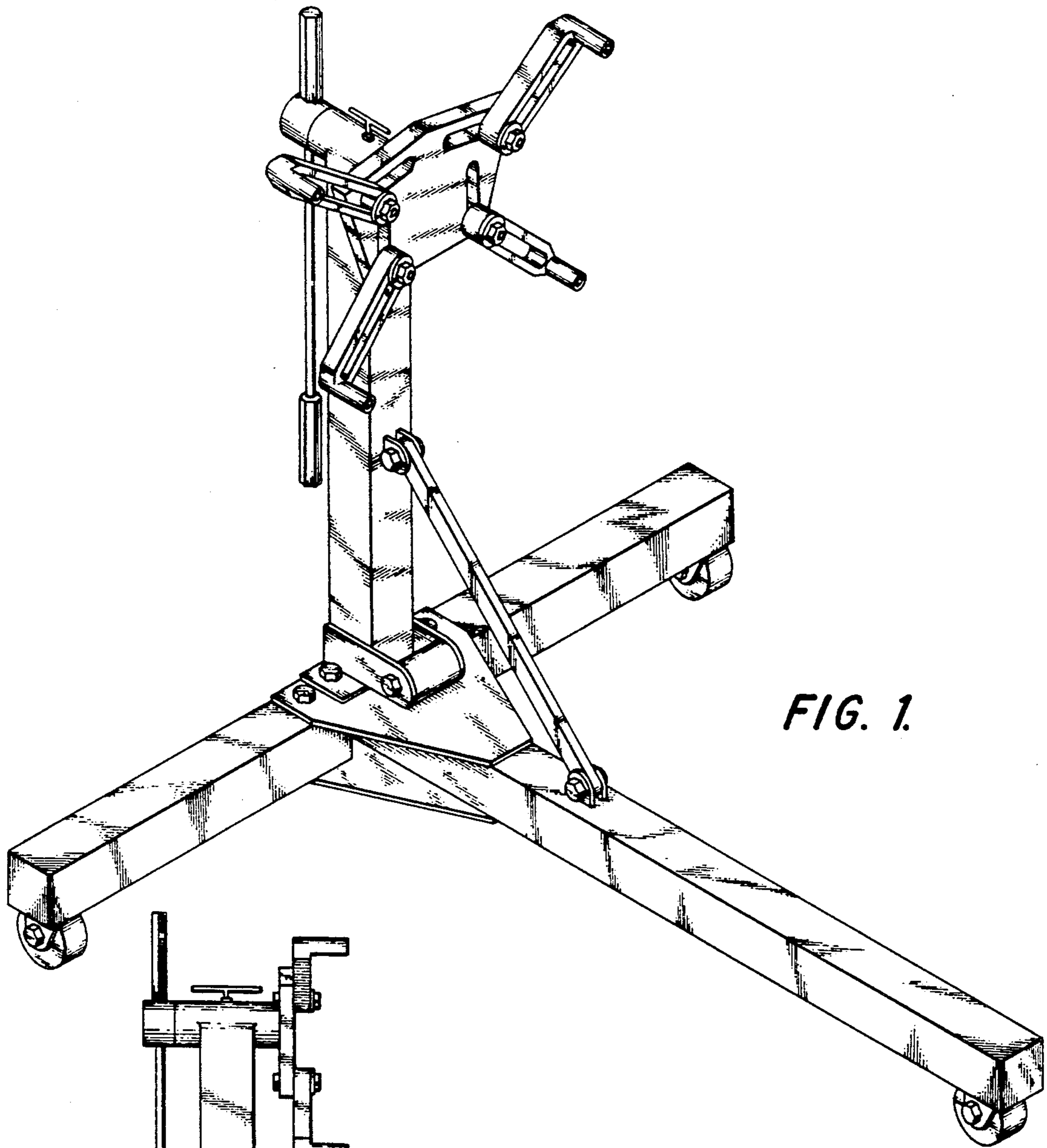

FIG. 1.

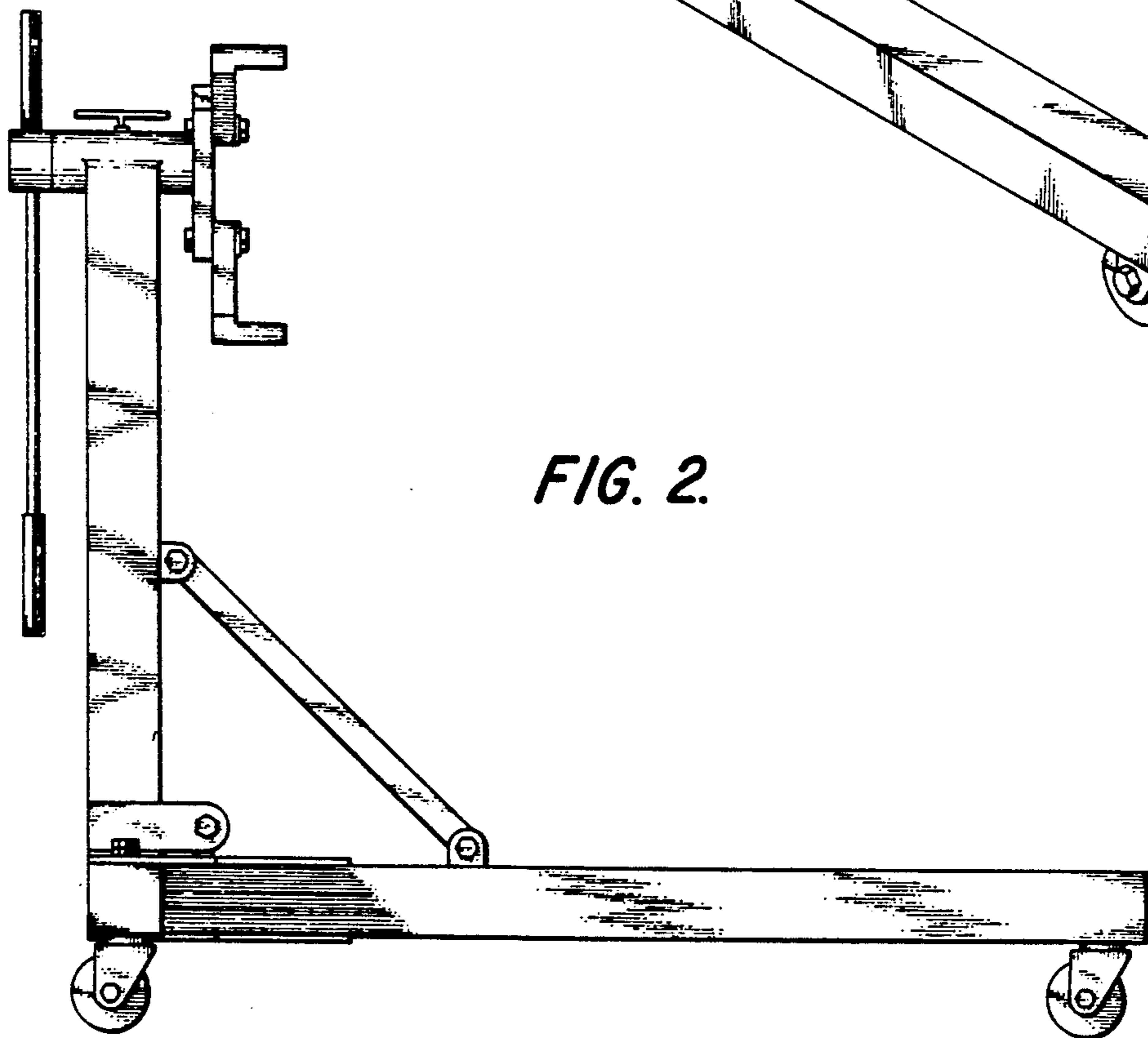

FIG. 2.

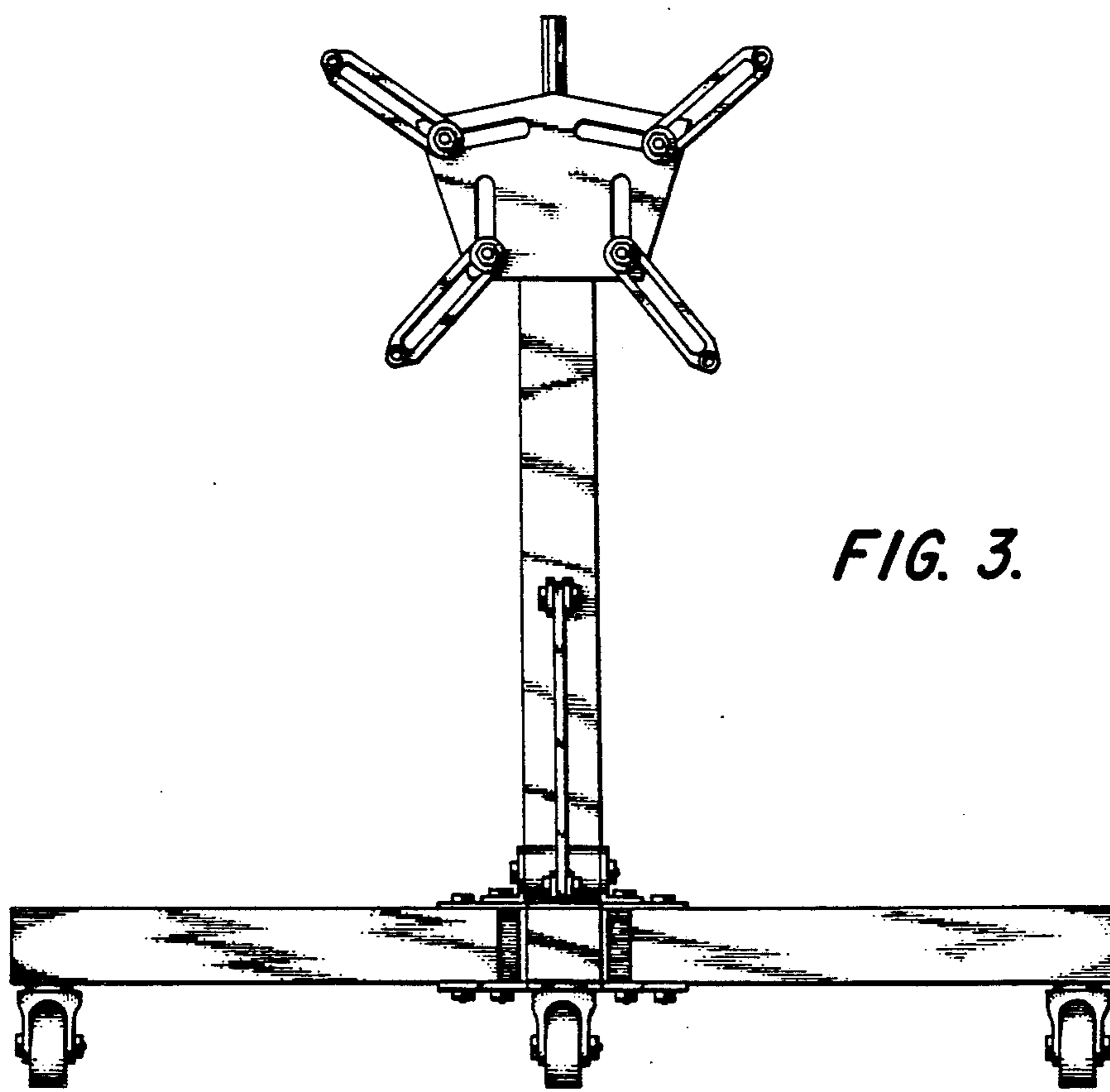

FIG. 3.

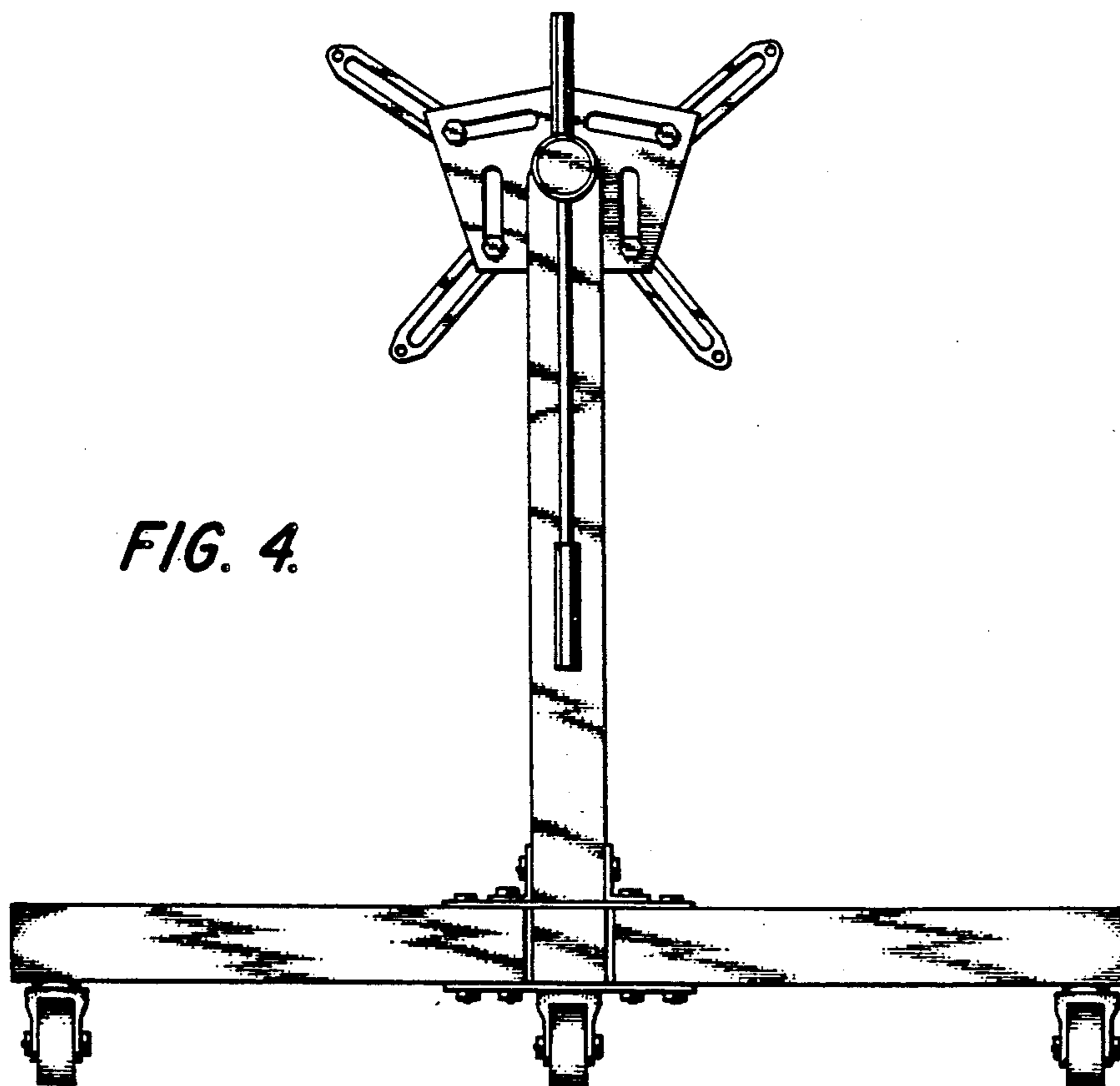

FIG. 4.

FIG. 5.

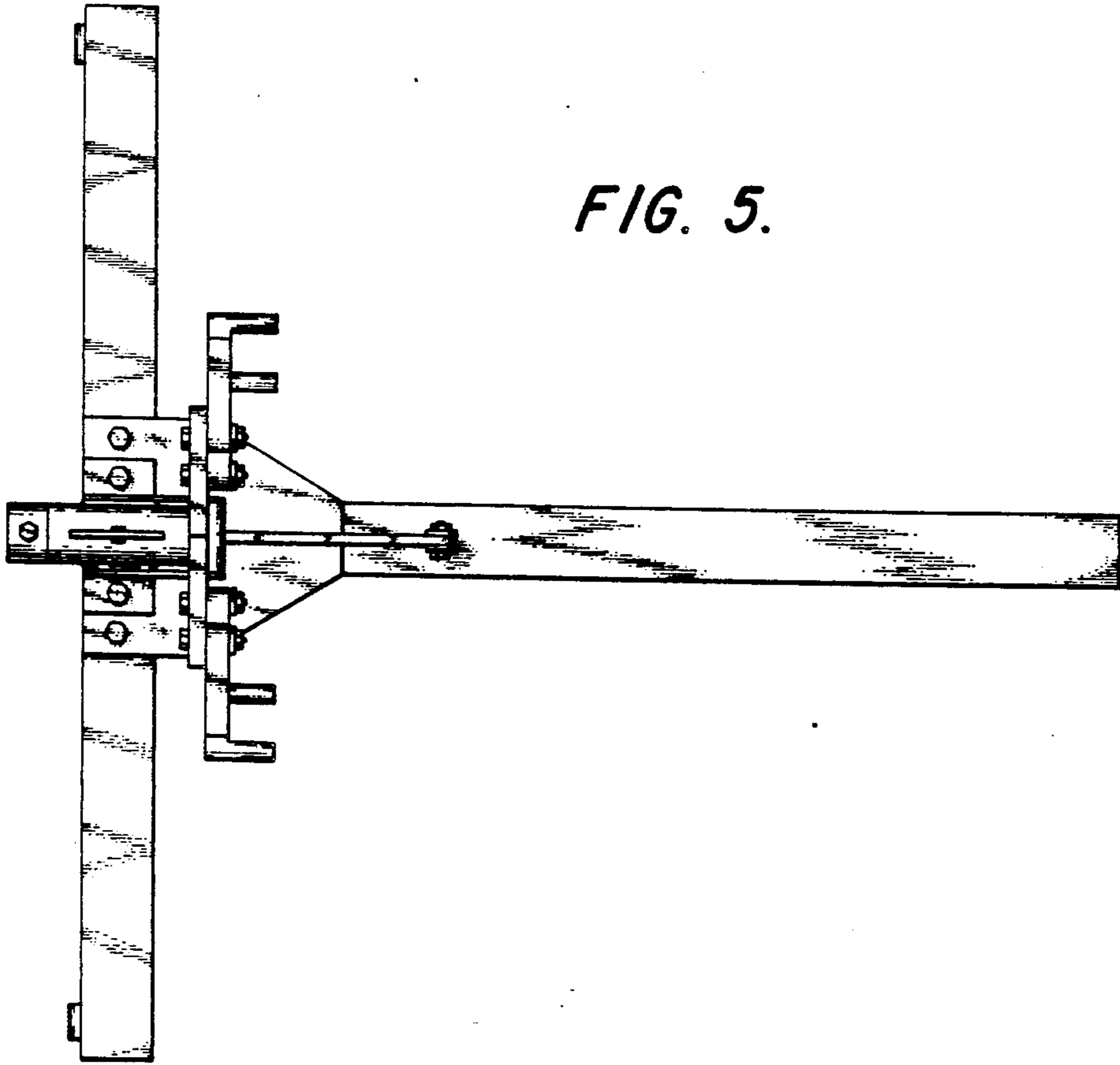
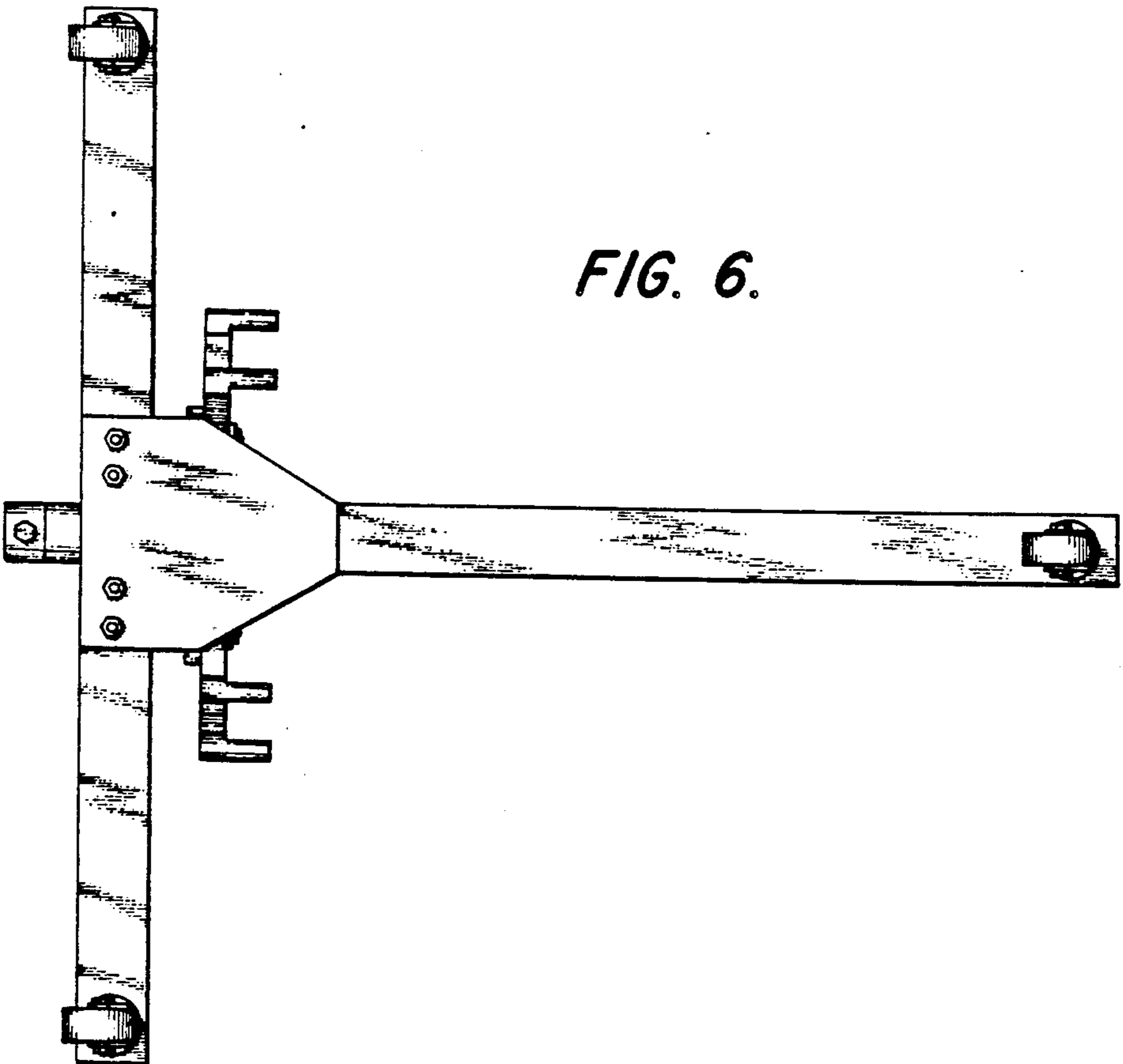

FIG. 6.



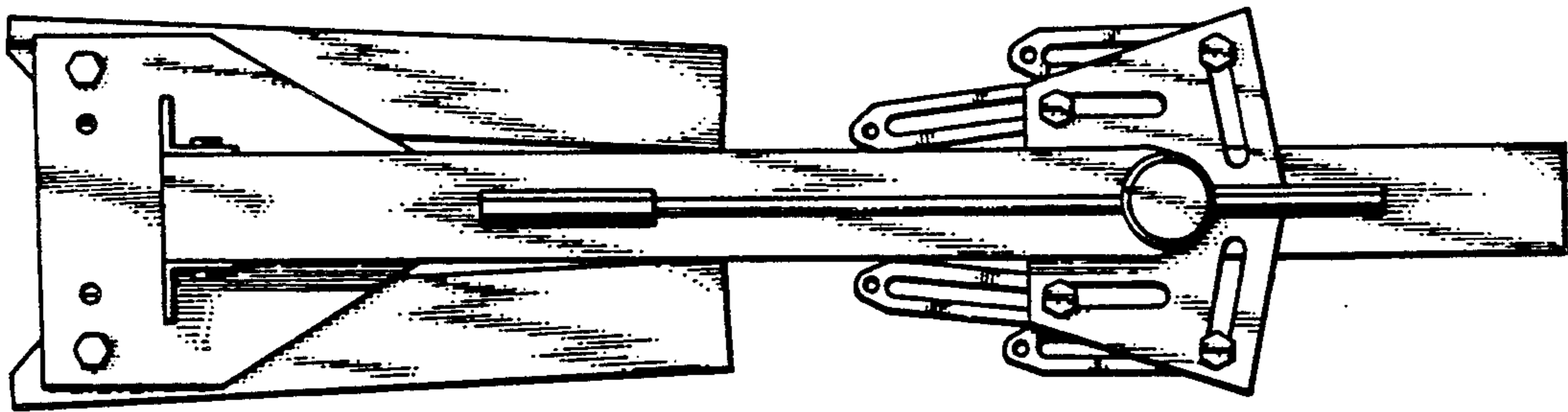

FIG. 7.