



US00D324495S

United States Patent [19]

[11] Patent Number: **Des. 324,495**

Warrington

[45] Date of Patent: **** Mar. 10, 1992**

[54] **CONTAINER**

D. 306,557 3/1990 Peake-Atkins D9/376
D. 312,210 11/1990 Myerson et al. D9/376

[75] Inventor: **Bernard Warrington, Whaddon, United Kingdom**

OTHER PUBLICATIONS

[73] Assignee: **Castrol Limited, United Kingdom**

Scepter Advertisement, Scepter Gasoline Container in front, item M12.

[**] Term: **14 Years**

Primary Examiner—Melvin B. Feifer
Assistant Examiner—Lucy Lieberman
Attorney, Agent, or Firm—Wood, Phillips, Mason, Recktenwald & Vansanten

[21] Appl. No.: **580,296**

[22] Filed: **Sep. 10, 1990**

[30] **Foreign Application Priority Data**

[57] **CLAIM**

Mar. 10, 1990 [GB] United Kingdom 2005368

The ornamental design for a container, as shown and described.

[52] U.S. Cl. **D9/376**

[58] Field of Search D9/376, 374, 378;
215/1 R, 1 C, 100 A

DESCRIPTION

[56] **References Cited**

FIG. 1 is a perspective view of a container showing my new design;
FIG. 2 is a front elevation thereof;
FIG. 3 is a rear elevation thereof;
FIG. 4 is a right side elevation thereof, the left side elevation is a mirror image thereof;
FIG. 5 is a top plan view thereof; and
FIG. 6 is a bottom plan view thereof.

U.S. PATENT DOCUMENTS

- D. 205,550 8/1966 Morgan D9/376
- D. 227,345 6/1973 Bell D9/374
- D. 272,318 1/1984 Visser D9/376
- D. 279,078 6/1985 Franchi et al. D9/376
- D. 287,226 12/1986 Lyons D9/376 X

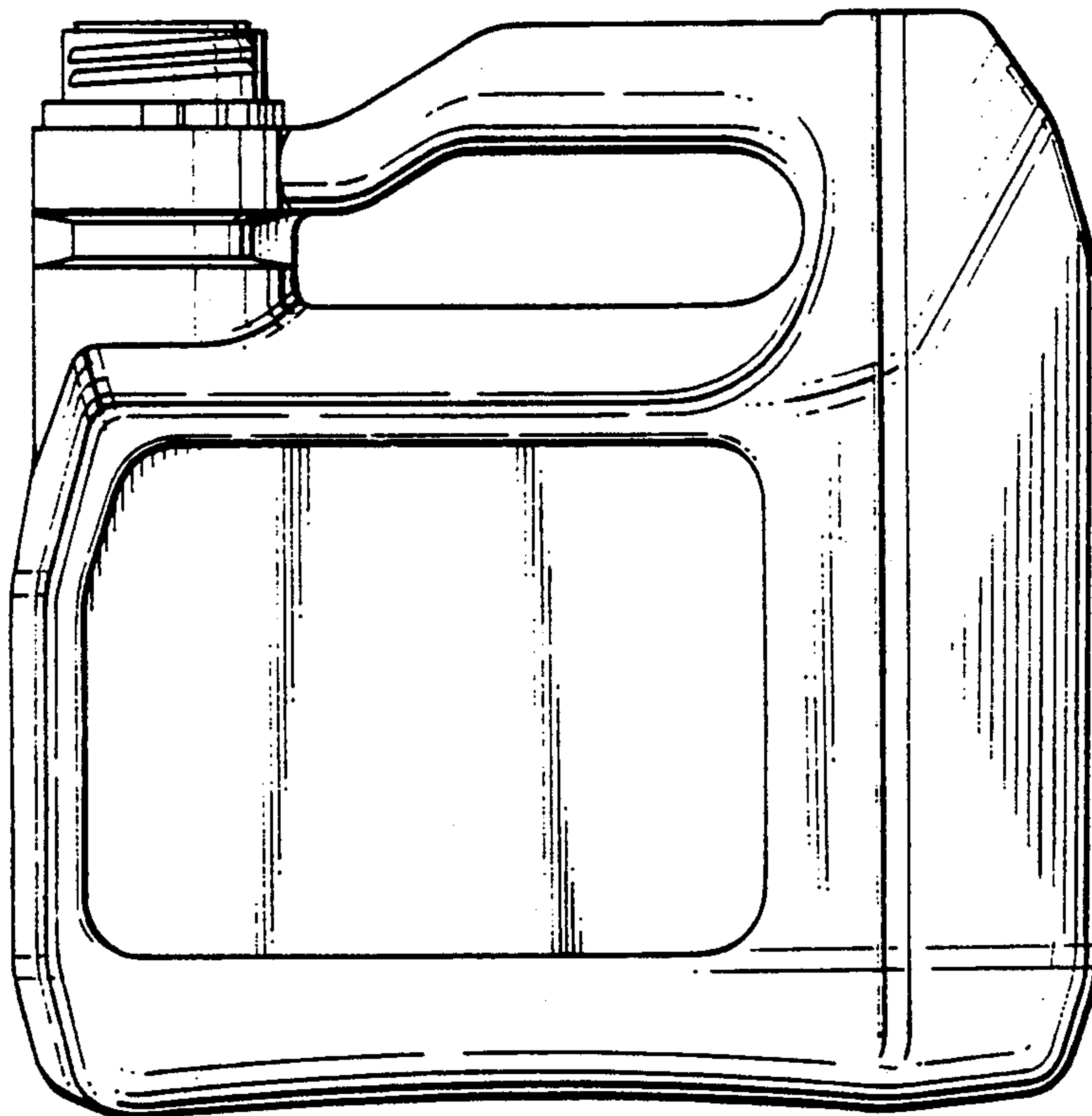

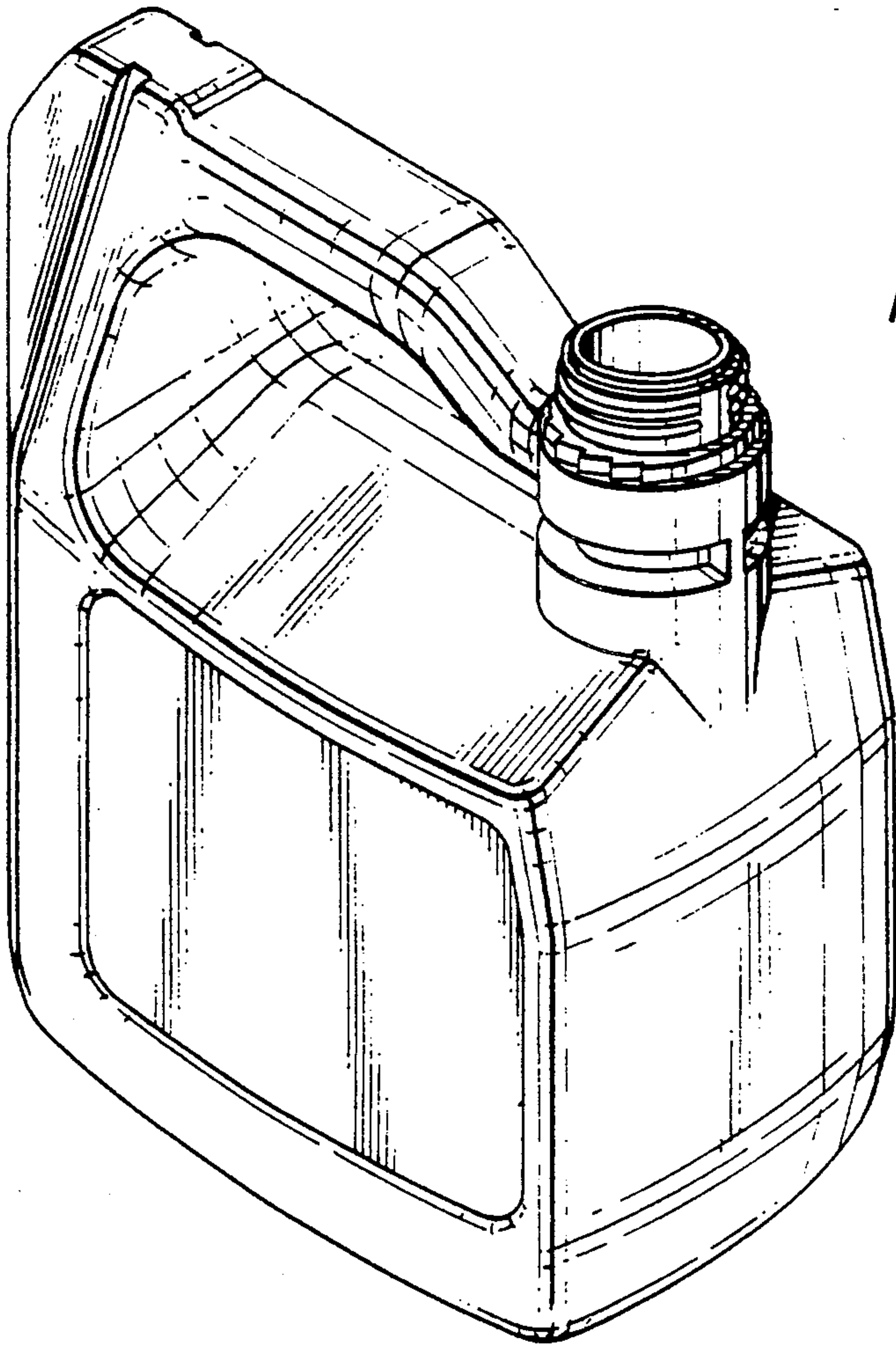

FIG. 1

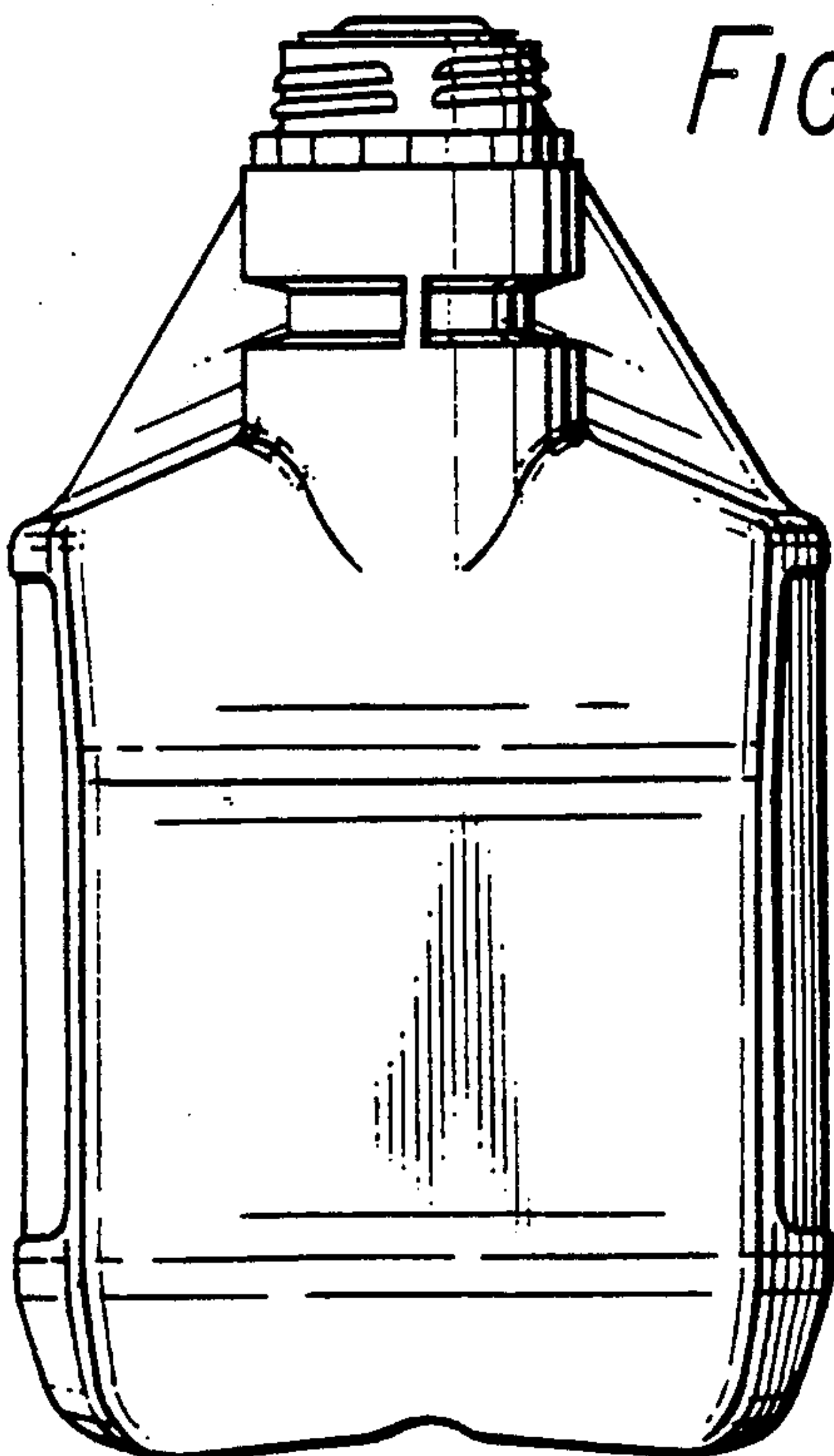

FIG. 2

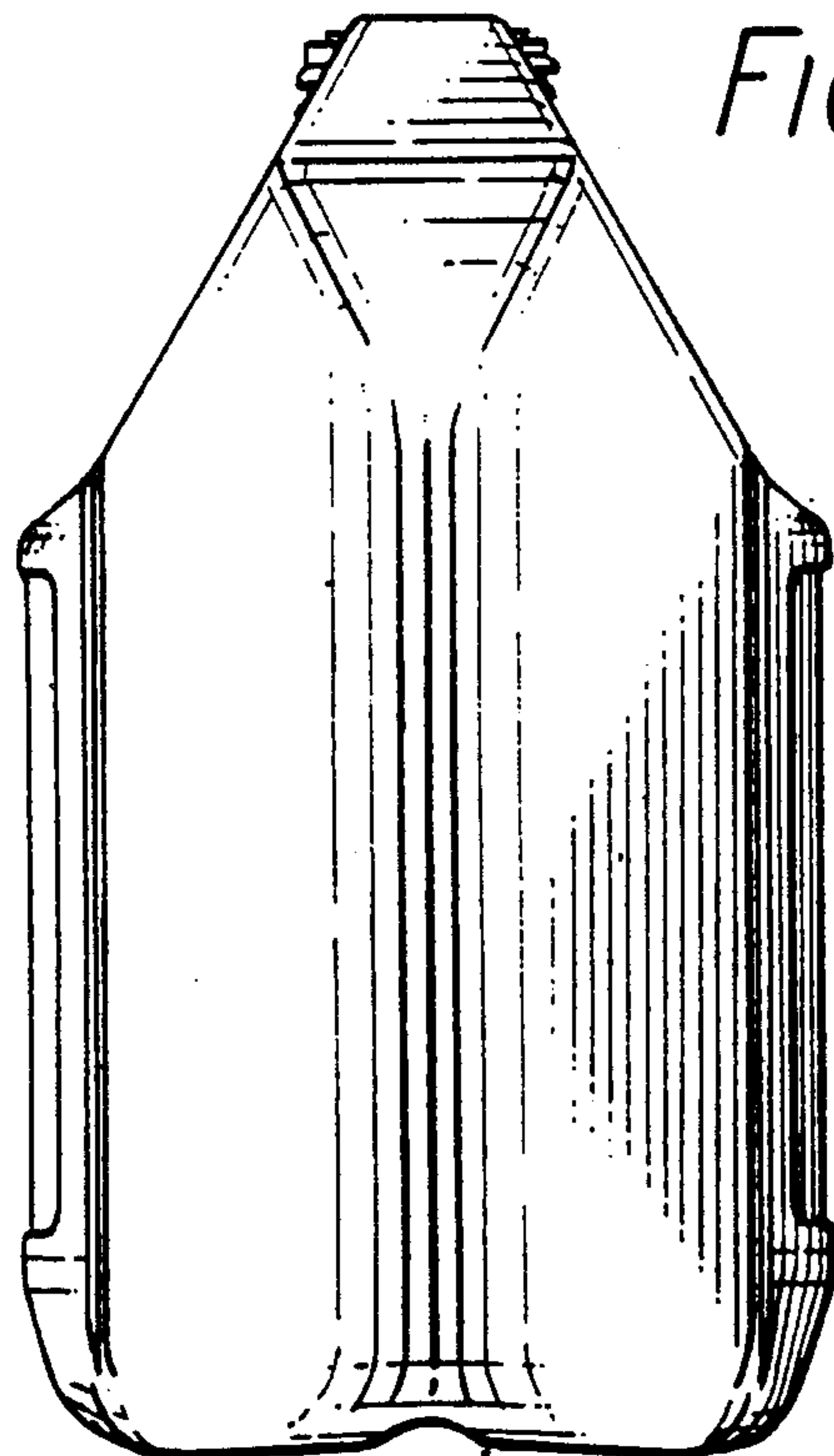

FIG. 3

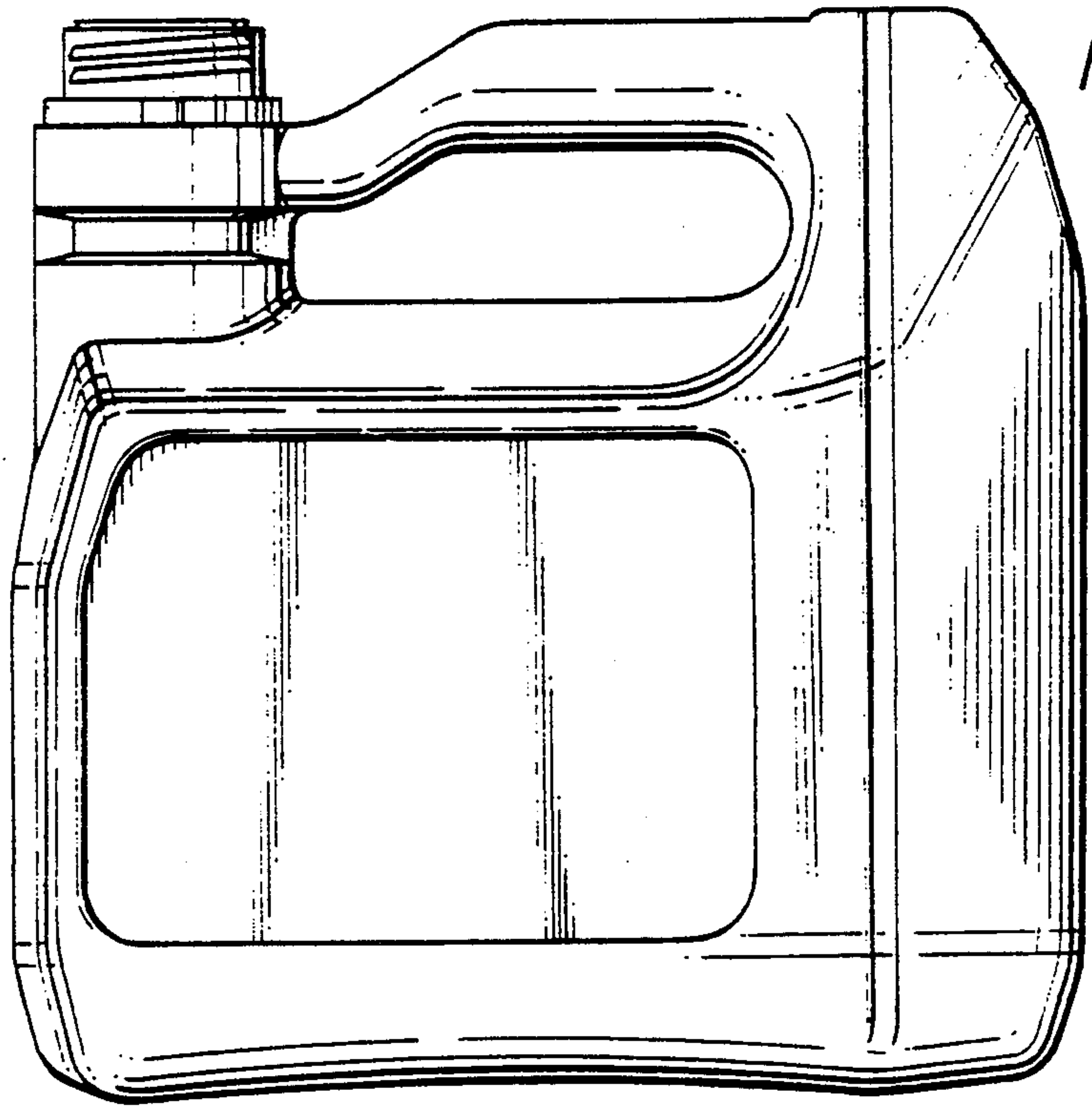

FIG. 4

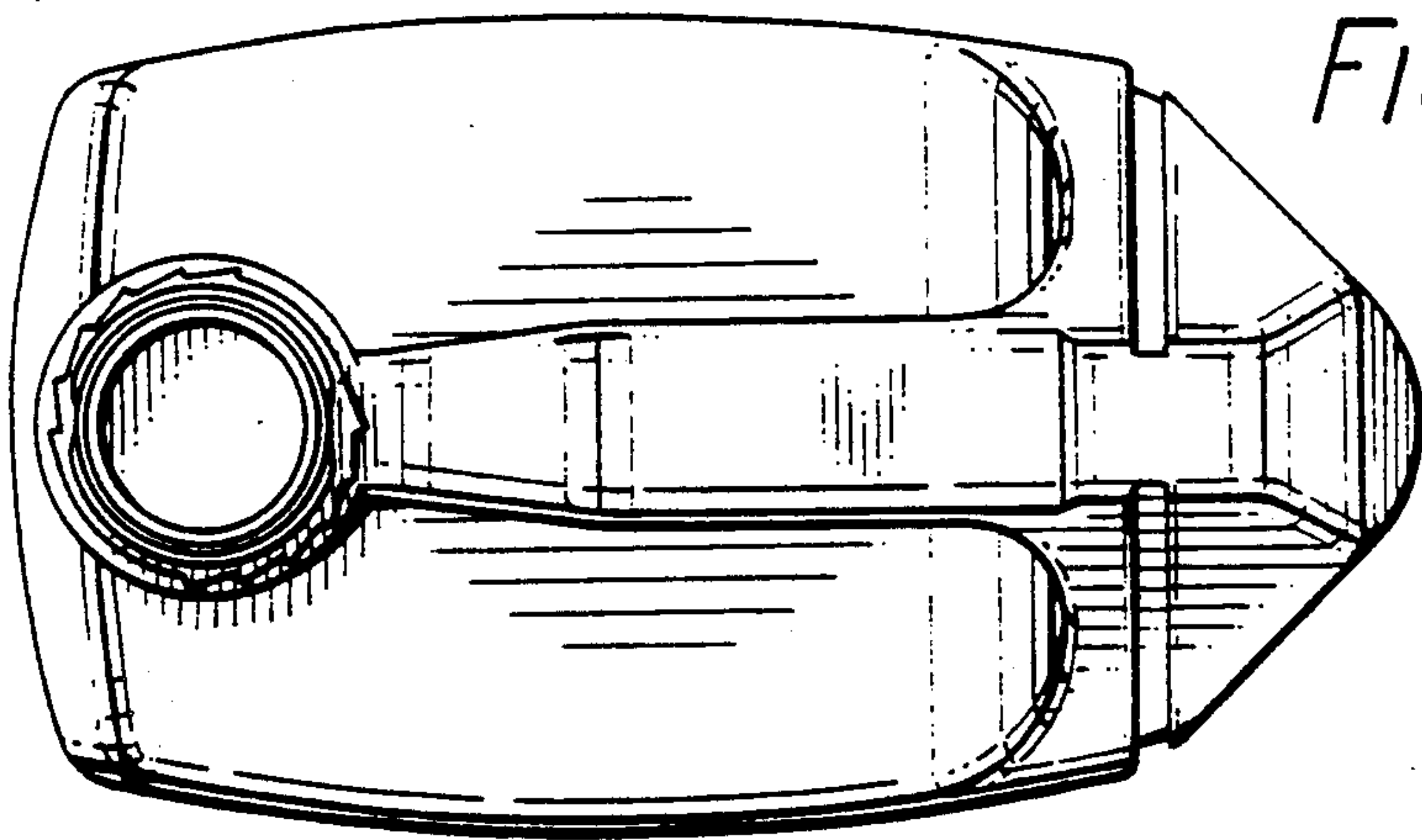

FIG. 5

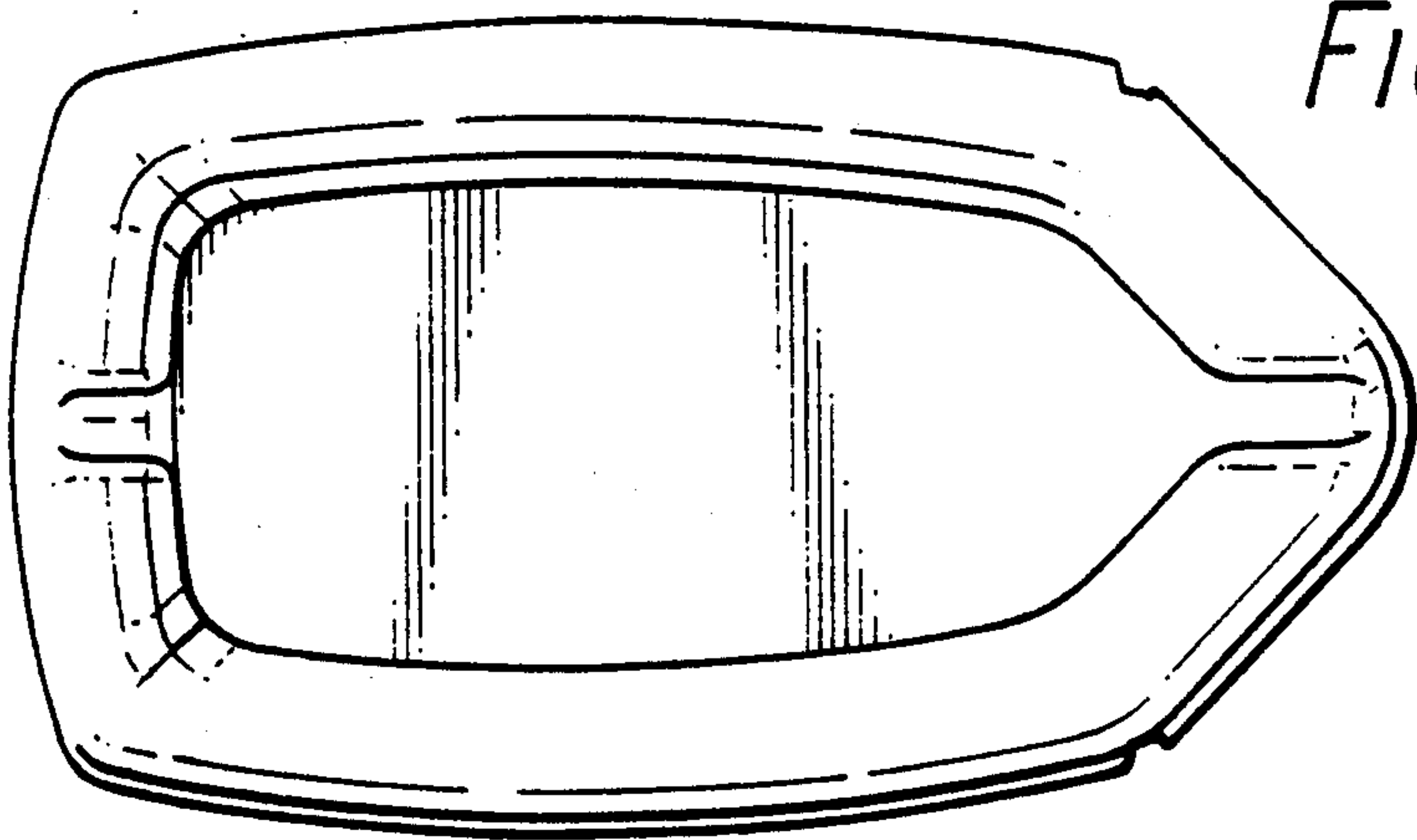

FIG. 6